

**Graber RTS Motorization
English/US Price Guide**

MOTORIZED BLINDS AND SHADES FEATURING RADIO TECHNOLOGY SOMFY (RTS) TECHNOLOGY

Product Information Guide

Features and Size Considerations

Motorized Blinds and Shades	2
Radio Frequency	2
Channel and Control Assignments	2
Standard Motors	2
CrystalPleat® Cellular Shades Motorized Lift	3
Pleated Shades Motorized Lift	4
Fresco® Roman Shades Motorized Lift	5
Horizontal Blinds Motorized Tilt	6
Tradewinds® Natural Shades Motorized Lift	7
Artisan Roman Shades Motorized Lift	8
Mezzanine Layered Shades Motorized Lift	9
Overture Sheer Shades Motorized Lift	10
Lightweaves® Roller and Solar Shades Motorized Lift	11
Motorized Lift: Mounting Depth Illustrations	12
Roller and Solar Shades: 12-Volt Motor: Maximum Shade Size (12V Sonesse 28 RTS WF Ext Batt and 12V Sonesse 28 RTS WF Li-ion)	13–20
Roller and Solar Shades: 12-Volt Motor: Maximum Shade Size (12V Sonesse 30 Ultra RTS WF Li-ion)	21–28
Roller and Solar Shades: 24-Volt Motor Maximum Shade Size (24V RTS SON30 Motor)	21–28
Roller and Solar Shades: 120-Volt Motor Maximum Shade Size	29–34
Roller and Solar Shades: Dual Shades Maximum Shade Size	35–41
Exterior Solar Shades Motorized Lift, Maximum Shade Size	42–43

Options

Guide Cables	44
Exterior Solar Shades Motorization Controls	44
Low Voltage 12-Volt Power Components	45
Rechargeable Power Considerations	45
Low Voltage 12-Volt and 24-Volt Power Considerations	46
Battery Autonomy (Years)	47
120-Volt Power Considerations	48
Radio Frequency Controls (RTS range 65 feet)	49
Specialty Radio Frequency Controls	50
Integration Devices	51
Standard 4-Wire Motor 120-Volt Controls	52

GRABER®

OCTOBER 2023

(10/23) 23-499350

Features and Size Considerations

Motorized Blinds and Shades

Refer to individual base product information guide for specific option and size information for the product being ordered.

RTS Motorization: this category has been offered by Graber® for quite some time and has been a workhorse family of motors for cellular, pleated, solar, roller, natural, Fresco® Roman, Artisan Roman, sheer, layered shades, and our tilt products.

Radio Frequency (RF)

Motorized Graber blinds and shades feature Somfy radio frequency motors and accessories. All Somfy radio frequency motors utilize Somfy's proprietary protocol Radio Technology Somfy® (RTS). Motorized blinds and shades feature the following:

- Window treatments can be operated from virtually anywhere in the home up to 65 feet
- Provides easy operation of hard-to-reach or large windows
- Efficiently manages energy (heat gain and loss)
- Operate multiple window treatments simultaneously or individually
- A safer alternative to corded lift options; ideal for homes with children and pets
- Easily integrated with home automation systems
- Not available with hold down brackets or specialty window treatments

Control and Power Options

- Multiple control and power options available; see options section for availability

Channel and Control Assignments for RTS Motors

Channel and control assignments are available when you purchase motorized window coverings. Specifying channels simplifies your install process by pre-programming each shade to the appropriate channel and control for your order.

- Each individual window covering can be assigned to a single channel, enabling unique control; multiple window coverings can also be assigned to an individual channel, enabling group control
 - Channel assignment is recommended on all radio frequency (RF) controls within the same product type
 - Custom programming available on handheld remotes, and wall switches only

Standard Motors (4-wire)

- Available with solar and roller products only
- Standard motors are hard-wired both to power (line voltage) and controls
- 120-volt motors allow operation of large shades (see motorization size charts)
- Hard-wired controls provide the most reliable control of shades
- Control options include
 - Wall switches for convenient, reliable control or dry contact outputs provided by certain home automation packages
 - Group controllers to operate multiple shades with a single switch

Features and Size Considerations

CrystalPleat® Cellular Shades Motorized Lift

Motor Type: 12V RTS CL32 Motor (Somfy RTS)

Refer to individual product information guide for specific option information for the product being ordered. See page 2 for benefits of using RTS Motorization.



Features

- Low voltage motorization requires no costly electrical hard-wiring
- Motor located on right side within the headrail
- Multiple shades on one headrail available; each panel will have a motor and power source
- Not available with bottom up/top down, sun up/sun down, top down only, SkyTrack™, combination shade, or specialty shapes
- Not available with cut outs, room darkening side channels, hold down or side mount brackets.
- Available as corner and bay window applications
- Available with Wood Cornice and Valance
- Available with reversible fabric at time of order
- Available with lightblocking strip
- Rail colors can be specified at time of order
- Available with fabric wrapped rail

Control and Power Options

- Multiple control and power options available; see options section for availability

NOTE: Motorization components and accessories have a five-year limited warranty, excluding batteries.

Size Considerations

Motor Type	Minimum Width (inches)	Maximum Width (inches)	Minimum Height (inches)	Maximum Height (inches)
Somfy RTS (CL32)	20	144*	9	144*

*This is the shade size maximum limit for this motor type, shades size limit may be smaller based on specific fabric type.

For all inside mount applications, 3/8" deduction is taken by the manufacturer on overall width.

Cell Size	Collection Name	Maximum Shade Size (square inches)
1/2" Double Cell	Sanctuary	7,500
1/2" Double Cell	Splendor	11,500
3/4" Single Cell	Champagne Toast, Couture LF and BO, Enchantment BO, Infuse BO, Kinsley LF and BO, Montage BO, Prestige BO, Sanctuary, Scroll FR, Valletta BO,	9,000
3/4" Single Cell	Infuse LF, Valletta LF	11,500
3/4" Single Cell	Enchantment LF, Montage LF, Prestige LF, Discovery BO, Endeavor LF, Simply sheer, Splendor LF	13,000
9/16" Single Cell	Discovery BO	9,000
9/16" Single Cell	Endeavor LF	13,000
1 1/4" Single Cell	Splendor LF	11,500
1 1/4" Single Cell	Champagne Toast, Sanctuary BO, Valletta LF and BO	9,000

See page 45 for Power Consideration size information.

Depth Requirements for Inside Mount

Cell Size	Headrail Dimensions (inches)	Headrail Mounting Diagrams	
		Partially recessed headrail in window casing/molding. Minimum Depth Mount (inches)	Fully recessed headrail in window casing/molding. Flush with Casing (inches)
3/4" single cell 1/2" double cell	1 1/16" x 2 3/8"	5/8"	2 5/8"
9/16" single cell	1 1/16" x 2 1/8"	5/8"	2 3/8"
1 1/4" single cell	1 5/8" x 3 1/16"	1"	3 3/8"

Features and Size Considerations

Pleated Shades Motorized Lift

Motor Type: 12V RTS CL32 Motor (Somfy RTS)



Refer to individual product information guide for specific option information for the product being ordered. See page 2 for benefits of using RTS Motorization.

Features

- Low voltage motorization requires no costly electrical hard-wiring
- Motor located on right side within the headrail
- Multiple shades on one headrail available; each panel will have a motor and power source
- Available for standard bottom up shades; not available with specialty shapes
- Not available with hold down or side mount brackets
- Available as corner and bay window applications
- Available with Wood Cornice and Valance
- Available with Privacy and Blackout liner
- Available with lightblocking strip
- Rail colors can be specified at time of order

Control and Power Options

- Multiple control and power options available; see options section for availability

NOTE: Motorization components and accessories have a five-year limited warranty, excluding batteries.

Size Considerations

Motor Type	Shade Type	Minimum Width (inches)	Maximum Width (inches)	Minimum Height (inches)	Maximum Height (inches)
Somfy RTS (CL32)	1" FashionPleat	20	144	9	96
	1" EvenPleat	20	120	6	96
	2" EvenPleat	20	144*	12	120

*This is the shade size maximum limit for this motor type, shades size limit may be smaller based on specific fabric type.

For all inside mount applications, 3/8" deduction is taken by the manufacturer on overall width.

Pleat Size	Collection Name	Maximum Shade Size (square inches)
1" Pleated	Aberdeen, Canyon Ridge, Cloud Metal, Debonair, Desert, Grasscloth, Marina, Prescott, Sahara Ridge, Serendipity, Spring Bloom, Terrain	9,000
1" Pleated	Allure, Inkblot, Sheer Linen	11,500
1" Pleated	Blackout and Privacy Liner Only	13,000
2" Pleated	Aberdeen, Cloud Metal, Debonair, Desert, Sahara Ridge, Serendipity, Spring Bloom, Terrain	7,500
2" Pleated	Sheer Linen	11,500
2" Pleated	Blackout and Privacy Liner Only	13,000

See page 45 for Power Consideration size information.

Depth Requirements for Inside Mount: Motorized Lift

Shade Type	Headrail Dimensions (inches)	Partially recessed headrail in window casing/molding Minimum Depth Mount (inches)	Fully recessed headrail in window casing/molding Flush with Casing (inches)
1" Pleat	1 ¹ / ₁₆ X 2 ¹ / ₁₆	5/8	2 ³ / ₈
2" Pleat	1 ¹ / ₁₆ X 2 ³ / ₈	5/8	2 ³ / ₈

Features and Size Considerations

Fresco® Roman Shades Motorized Lift

Motor Type: 12V RTS CL32 Motor

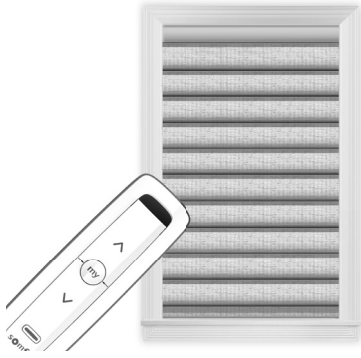

Refer to individual product information guide for specific option information for the product being ordered. See page 2 for benefits of using RTS Motorization.

Features

- Low voltage motorization requires no costly electrical hard-wiring
- Motor located on right side within the headrail
- Multiple shades on one headrail available; each panel will have a motor and power source
- Not available with bottom up/top down
- Not available with hold down or side mount brackets
- Available as corner and bay window applications
- Available with Wood Cornice and Valance
- Available with Flat and Looped styles
- Available with fabric valance and fabric valance trims

Control and Power Options

- Multiple control and power options available; see options section for availability

NOTE: Motorization components and accessories have a five-year limited warranty, excluding batteries.

Roman Size Considerations	Minimum Width* (inches)	Maximum Width (inches)	Minimum Height (inches)	Maximum Height (inches)
Roman Shades: Classic Flat or Looped	20	76†	18	96

*For all inside mount applications, 3/8" deduction is taken by manufacturer on overall width.

†Based on fabric width.

See page 45 for Power Consideration size information.

Depth Requirements for Inside Mount

Lift Option and Shade Style	Headrail Dimensions (inches)	Partially recessed headrail in window casing/molding Minimum Depth Mount (inches)	Fully recessed headrail in window casing/molding Flush with Casing (inches)
Motorized Lift: Flat	1 1/16 x 2 7/8	5/8	2 1/2
Motorized Lift: Looped	1 1/16 x 2 7/8	1/2 (fabric loops will overhang approximately 3" into the room)	2 1/2 (fabric loops will overhang approximately 3" into the room)

Features and Size Considerations

Horizontal Blinds Motorized Tilt

Motor Type: Ring Lift with Motorized Tilt



Refer to individual product information guide for specific option information for the product being ordered. See page 2 for benefits of using RTS Motorization.

Available with: 2" Traditions® Wood Blinds
 2³/₈" Traditions Wood Blinds
 2" Elite Wood Blinds
 2³/₈" Elite Wood Blinds
 2" Traditions Composite Blinds
 2¹/₂" Traditions Composite Blinds
 2" Vinyl Blinds
 2" Grandeur™ Aluminum Blinds

Features

- Motorization will only tilt slats; raising or lowering the blind is manual with cord lift
- Low voltage motorization requires no costly electrical hard-wiring
- Motor located on the left side within the headrail; cord lift is on the right side
- Not available with specialty shapes, hold down brackets, or multiple blinds on one headrail

Control and Power Options

- Multiple control and power options available; see options section for availability

NOTE: Motorization components and accessories have a five-year limited warranty, excluding batteries.

See page 45 for Power Consideration size information.



Size Considerations	Minimum Width (inches)	Maximum Width (inches)	Minimum Height (inches)	Maximum Height (inches)	Maximum Size (square inches)
Wood/Composite Blinds	19	96	10	120	2" and 2 ³ / ₈ " : 7,200 2 ¹ / ₂ " : 6,480
2" Vinyl	19	84	9 ³ / ₈	108	7,200
2" Aluminum	19	84	9 ³ / ₈	126	7,200

EXAMPLE: 96" wide x 96" high = 9,216 square inches (over maximum size)
 18" wide x 62" high = 1,116 square inches (under minimum width)
 67" wide x 84" high = 5,628 square inches (size is within acceptable range)

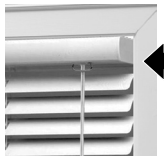
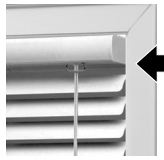
Depth Requirements for Inside Mount: Aluminum

Headrail Dimensions (inches)	Minimum Depth Mount (inches)	Flush with Casing (inches)	Flush Mount with Valance (inches)
1 ⁵ / ₈ x 2 ¹ / ₄	 Partially recessed headrail in window casing/molding 3/4	 Fully recessed headrail in window casing/molding 2 ³ / ₈	3 ¹ / ₈

Depth Requirements for Inside Mount: Vinyl

Headrail Dimensions (inches)	Minimum Depth Mount (inches)	Flush with Casing (inches)
1 ⁵ / ₈ x 2 ¹ / ₄	 Partially recessed headrail in window casing/molding 3/4	 Fully recessed headrail in window casing/molding Without valance: 2 ³ / ₈ With standard valance: 3 ³ / ₁₆ With double valance: 4

Features and Size Considerations

Tradewinds® Natural Shades Motorized Lift

Motor Type: 24v RTS SON30 Motor

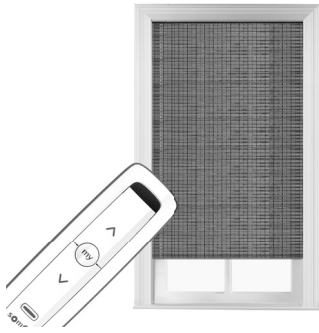

Refer to individual product information guide for specific option information for the product being ordered. See page 2 for benefits of using RTS Motorization.

Features

- Available on standard Roman or old style Roman
- Available with deco-trim hems and accent gimp
- Available with privacy and room-darkening liners
- Available with 9" standard valance, 9" premier valance, or 9" deco-trim valance
- Available with fabric edge banding and liners
- Motor mounted to the underside of hardwood headrail on right side
- Not available with looped Roman, bottom up/top down, angle top, or hold down brackets
- Available with bottom corner and bottom center cut-outs

Control and Power Options

- Multiple control and power options available; see options section for availability

NOTE: Motorization components and accessories have a five-year limited warranty, excluding batteries.

See page 45 for Power Consideration size information.

Motorization Options	Yes	No
Standard Roman	•	
Old Style Roman	•	
Looped Roman		•
Multiple Shades on One Headrail	•	

Style	24-Volt Minimum Width (inches)	Maximum Size 24-Volt	
		Shade (square inches)	With Liner (square inches)
Inan, Lipo, Moniz, Revelry, Serenity, Toushan II	24	3,821	3,235
Brooklyn, Denver, Reminisce, Stateside	24	6,240	4,800
Bellamy, Seasons	24	7,219	5,376
Boardwalk, Merino, Sarto	24	8,410	6,010
Bayport, Beachfront, Hadley, Kelton, Oxford, Paralian, Verity, Wild Haven	24	9,513	6,547
Berwick, Cameron, Cherish, Interlude, Olympia, Rowen, Purcell, Saterra, Selene, Tatum, Terrestrial, Ventura, Zishan	24	11,520	7,920

Depth Requirements for Inside Mount

Headrail Dimensions (inches)	Minimum Depth Mount (inches)	Flush with Casing (inches)
$\frac{5}{8} \times 2\frac{1}{4}$	$\frac{3}{4}$	Standard valance $3\frac{3}{16}$

Features and Size Considerations

Artisan Roman Shades Motorized Lift

Motor Type: 24v RTS SON30 Motor



Refer to individual product information guide for specific option information for the product being ordered. See page 2 for benefits of using RTS Motorization.

Features

- Low voltage motorization requires no costly electrical hard-wiring
- Fabric wrapped headrail for a beautifully finished look; returns are standard on outside mount
- Available as pleated styles: Looped, Classic Flat; Seamless or Relaxed
- Available with liner styles: Standard, water repellent, thermal, flannel-back
- Available finishing options: Inset banding, edge banding, decorative tape
- Motor mounted to the underside of hardwood headrail on left or right side; standard on right
- Not available with balloon pleat, blackout liner, or multiple shades on one headrail

Control and Power Options

- Multiple control and power options available; see options section for availability

NOTE: Motorization components and accessories have a five-year limited warranty, excluding batteries.

See page 45 for Power Consideration size information.

Size Considerations

Width		Height		
Minimum (inches)	Maximum (inches)	Minimum (inches)	Classic, Seamless, and Relaxed Shades Maximum (inches)	Looped Shades Maximum (inches)
24	96	18	120	103

Motorized Maximum Shade Area

Fabric Name	24-Volt Motorized Lift	
	Standard (square inches)	Dimout (square inches)
Candor, Cloud Metal, Enchanting, Liana, Meredith, Piazza, Stanton	9,120	8,860
Absolute, Alea, Arcadia, Artesso, Aspirational, Beach Chalet, Bianca, Bisque, Bloomscape, Brandywine, Brooke, Callahan, Countryside, Diversions, Esperance, Gratitude, Grayson, Harmonious, Heilene, Hypnotic, Iconic, Kazlo, Manning, Newleaf, Pageantry, Palatial, Rainfall, Raleigh, Sea Paisley, Seafont, Spargel, Undertones, Valor, Whimsical	8,100	8,000
Affinity, Ainslie, Avid, Bountiful, Burnham, Casita, Chalkdust, Conceptual, Confidence, Downpour, Dreamscape, Florabar, Focus, Frond Mist, Gjusta, Hama, Ibiza, Imagination, Kelsey, Kings Garden, Kingsbury, Maisonette, Meadowlark, Mikado, Mysterious, Mystical, Painterly, Pastoral, Posy, Primavera, Reflection, Refuge, Richland, Rutherford, Sustained, Symbiotic, Textile, Tyrell, Uplifting, Venetian, Wonder, Woodblock	7,450	7,300
Assurance, Athens, Birch, Bursche, Carver, Checkerloom, Circumference, Cloverleaf, Cooperative, EarthWise, EnviroLiving, Environment, Garden, Meditations, Monorail, Skipping Rocks, Soliloquy, Steward, Thistlerock, Wexler	6,700	6,610

If fabric not listed, it is not available with the motorized lift option.

NOTE: Area is ordered width x ordered height in square inches

Depth Requirements for Inside Mount

Headrail Dimensions (inches)	Partially recessed headrail in window casing/molding	Fully recessed headrail in window casing/molding
2¼ D x ⅝ L	Minimum Depth Mount (inches) ¾	Flush with Casing (inches) 2⅞

Features and Size Considerations

Mezzanine Layered Shades Motorized Lift

Motor Type: 12V Sonesse 28 RTS WF Ext Batt



Refer to individual product information guide for specific option information for the product being ordered. See page 2 for benefits of using RTS Motorization.

Features

- Low voltage motorization requires no costly electrical hard-wiring
- Motor located on right or left side; standard on the right
- Static guard is necessary during dry conditions to prevent static build up.
- Available as corner and bay window applications
- Not available with Wood Cornice and Valance
- Fabric-wrapped cassette comes standard and creates a cohesive appearance in the window
- Not available with hold down brackets
- Down = down closed (shade lowered; stripes closed)
- My/Stop = down open (shade lowered; stripes open)

Control and Power Options

- Multiple control and power options available; see options section for availability

NOTE: Motorization components and accessories have a five-year limited warranty, excluding batteries.

See page 45 for Power Consideration size information.

Light Gap			
Motor End		Idle End	
Inside Mount (inches)	Outside Mount (inches)	Inside Mount (inches)	Outside Mount (inches)
1 ¹ / ₁₆	1	3 ⁴ / ₄	1 ¹ / ₁₆

The fabric width is narrower than the finished shade width of the tube and its components. See chart above for light gap.

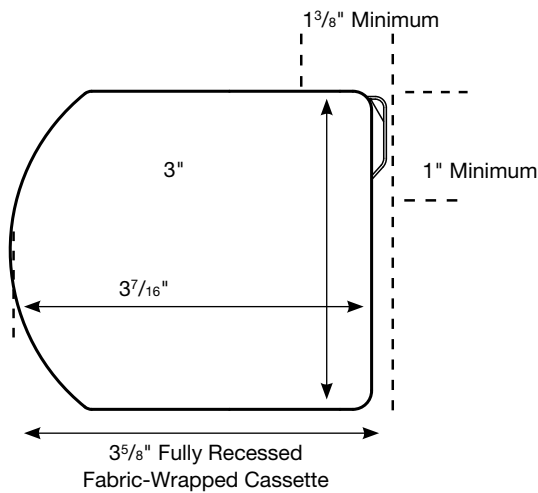

Minimum Mounting Depth	1 ³ / ₈ "
Minimum Mounting Depth, Flush Mount	3 ⁵ / ₈ "

Size Considerations		
Style Name	Maximum Width* (inches)	Maximum Height* (inches)
Atlantic Waves	100	75
Bernina	96	110
Coastal Collection	98	75
Coastal Ridge	98	60
Cordillera	85	75
Cottonwood	101	100
Crestones	97	84
Culebra	95	110
Glorieta	98	110
Glorieta Sheen	98	110
Heathered	95	77
Herard	97	77
Linen Dream	95	72
Oceanfront	99	60
Palmetto	97	100
Papyrus	98	60
Refreshed	93	84
Riptide	100	110
Seascape	98	77
Seaside Resort	99	110
Spascape	100	77
Vanoise	91	95

Minimum width: motorized lift 16".

Minimum height: 12"

*If the height is shorter than the maximum, a slightly larger width may be available to order. Maximum width is 102".

Features and Size Considerations

Overture Sheer Shades Motorized Lift

Motor Type: 12V Sonesse 28 RTS WF Ext Batt



Refer to individual base product information guide for specific option information for the product being ordered. See page 2 for benefits of using RTS Motorization.

Features

- Low voltage motorization requires no costly electrical hard-wiring
- Motor located on right or left side; standard on the right
- Fabric-wrapped cassette comes standard and creates a cohesive appearance in the window
- Available as corner and bay window applications
- Not available with Wood Cornice and Valance
- Not available with hold down brackets
- Down = down open (shade lowered; vanes open)
- My/Stop = down closed (shade lowered; vanes closed)

Control and Power Options

- Multiple control and power options available; see options section for availability

NOTE: Motorization components and accessories have a five-year limited warranty, excluding batteries.

See page 45 for Power Consideration size information.

Light Gap			
Motor End		Idle End	
Inside Mount (inches)	Outside Mount (inches)	Inside Mount (inches)	Outside Mount (inches)
1	1 ⁵ / ₁₆	1 ¹ / ₁₆	5 ¹ / ₈

The fabric width is narrower than the finished shade width of the tube and its components. See chart above for light gap.

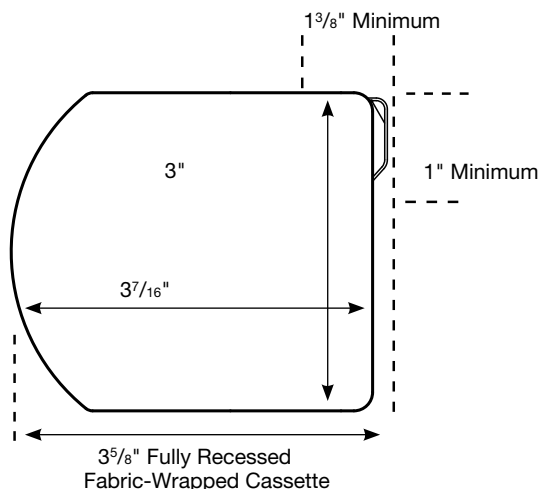

Minimum Mounting Depth	1 ³ / ₈ "
Minimum Mounting Depth, Flush Mount	3 ⁵ / ₈ "

Size Considerations		
Style Name	Maximum Width* (inches)	Maximum Height* (inches)
Alpine 2"	79	110
Coastal Waves 2"	96	105
Deco Diamond 2"	96	105
Deco Diamond 3"	96	65
Evening Star 2"	71	85
Glessner 2"/Glessner 3"	96	105
Glessner Sheen 2"/Glessner Sheen 3"	98	110
Glessner Woven 2"/Glessner Woven 3"	96	110
Lustrous 1"	102	69
Lustrous 2"	96	105
Marisco 2"/Marisco 2 3/4"	94	99
Modern Grid 1" 5301	102	69
Modern Grid 1" 5302, 5303, 5304	98	87
Modern Grid 1" 5300	94	75
Roslin 1"	94	75
San Simeon 3"	96	65
Starlight 2"	96	105
Starlight 3"	96	65
Sun Reflections 2"	96	105
Surfside 2"	96	105
Surfside 3"	96	65
Winchester 1"	97	87
Winchester Sheen 1"	102	69
Winchester Woven 1"	97	87

Minimum width: motorized lift 16".

Minimum height: 12"

*If the height is shorter than the maximum, a slightly larger width may be available to order. Maximum width is 102".

Features and Size Considerations

Lightweaves® Roller and Solar Shades Motorized Lift

Order Entry: See chart below



Refer to individual base product information guide for specific option information for the product being ordered. See page 2 for benefits of using RTS Motorization.

Features

- Line voltage has multiple wiring options and is ideal for large interior solar shades
- Not available with hold down brackets
- Available with standard or reverse roll; Reverse roll not available with any valance.
- Available with valance styles: cassette, contour, fascia, wood valance and wood cornice; 120v not available with cassette.
- Available with side channels with sealed hem bar only
- Motor located on the left or right side; standard on the right
- Rechargeable motors will be received at approximately 30% charge. Charging will be required before use.
- Available as corner and bay window applications
- Available with Wood Cornice and Valance
- Available as Dual Shade (integrates two fabrics that can be independently raised and lowered as needed); each shade requires a power source. Dual shade not available with rechargeable motors;
- Available with finishing options: scallops, gimp trim, bead trim

Control and Power Options

- Multiple control and power options available; see options section for availability

NOTE: Motorization components and accessories have a five-year limited warranty, excluding batteries.

Valance Type	Light Gap (inches)			
	Motor Type			
	12V RTS Sonesse 28 Ext Battery Motor	12V RTS Sonesse 28 Li-ion Motor/12V RTS Sonesse 30 Li-ion Motor	24V RTS SON30 Non-Rechargeable	120V STD ST40 Motor/120V RTS ST40 Motor
Contour, Flat, Fascia, No Valance	$\frac{1}{16}$ to $\frac{13}{16}$	$\frac{1}{16}$ to $\frac{13}{16}$	$\frac{1}{16}$ to $\frac{7}{8}$	$\frac{1}{16}$ to $1\frac{1}{8}$
All Flat Cassette Sizes	$\frac{1}{16}$ to $\frac{15}{16}$	$\frac{1}{16}$ to $\frac{15}{16}$	$\frac{1}{16}$ to 1	N/A
Dual No Cassette	$\frac{1}{16}$ to $\frac{13}{16}$	N/A	$\frac{1}{16}$ to $\frac{7}{8}$	N/A
Dual with Cassette	$\frac{1}{16}$ to 1	N/A	$\frac{1}{16}$ to 1	N/A

Size Considerations		
Motor Type	Minimum Width (inches)	Minimum Height (inches)
12V Sonesse 28 RTS WF Ext Batt	16	13
12V Sonesse 28 RTS WF Li-ion	24	
12V Sonesse 30 Ultra RTS WF Li-ion	30	
24V RTS SON30 Motor (16)	20	
120V STD ST40 Motor (5)	23	
120V RTS ST40 Motor (4)	24½	

NOTE: See size charts on following pages.

See page 45 for Power Consideration size information.

Motorized Size Considerations

Motorized Lift: Mounting Depth Illustrations

The following diagrams illustrate the mounting depth requirements for shades mounted inside window casements.

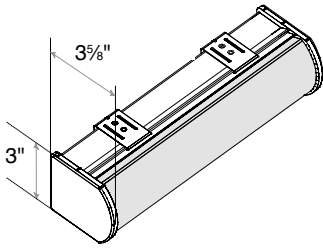

Small Cassette Valance
1 5/8" Minimum Inside Mount

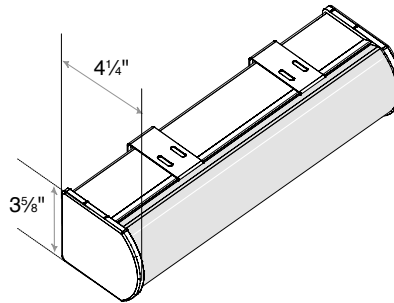

Medium Cassette Valance
1 3/4" Minimum Inside Mount

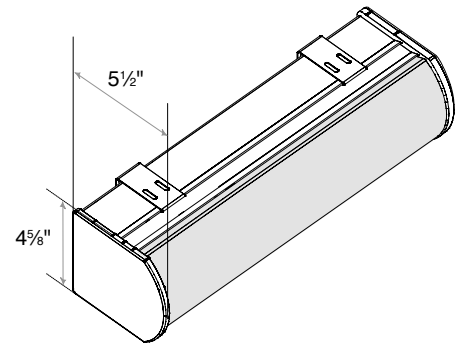

Large/Dual Cassette Valance
1 3/4" Minimum Inside Mount

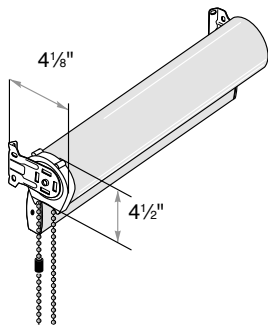

No Valance*
3/4" Minimum Inside/Side Mount

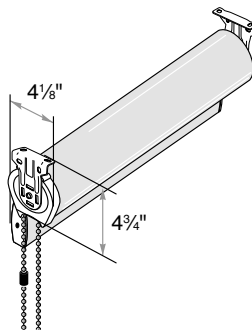

No Valance*
4 1/8" Minimum Inside/Top Mount

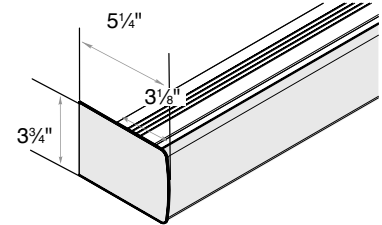

Contour Valance
2 7/16" Minimum Inside Mount
(return can be trimmed)

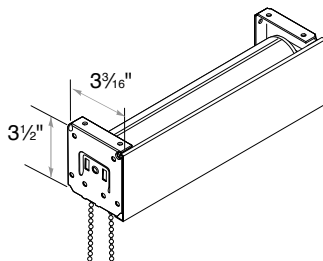

3" Fascia
2 3/4" Minimum Inside/Top Mount
3/4" Minimum Inside/Side Mount

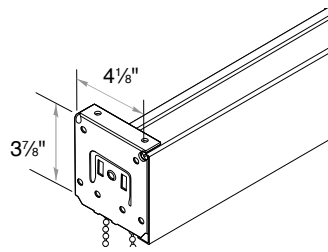

4" Fascia
3 3/4" Minimum Inside/Top Mount
1 1/2" Minimum Inside/Side Mount

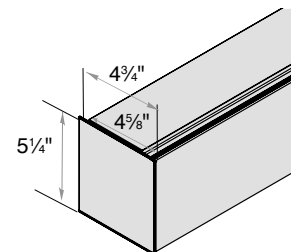

Flat Valance
2 15/16" Minimum Inside Mount
(return can be trimmed)

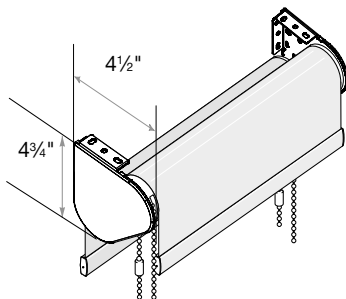

Dual Shade—No Cassette Valance
2" Minimum Inside/Top Mount
3/4" Minimum Inside/Side Mount

12V Sonesse 28 RTS WF Ext Batt
 Minimum Width: 16"
 Minimum Height: 13"

12V Sonesse 28 RTS WF Li-ion
 Minimum Width: 24"
 Minimum Height: 13"

Features and Size Considerations

Roller and Solar Shades: 12-Volt Motor Maximum Shade Size

Valance Type	Normal Fabric Orientation												Fabric Turned Width for Height (railroaded)																					
	Small Cassette			Medium Cassette			Large Cassette/ Contour Valance/ No Cassette/ No Valance			3" Fascia			4" Fascia			Small Cassette			Medium Cassette			Large Cassette/ Contour Valance/ No Cassette/ No Valance			Large Cassette/ Contour Valance/ No Cassette/ No Valance at Maximum Width			3" Fascia			4" Fascia			
	Width (inches)	Height (inches)	Width (inches)	Height (inches)	Width (inches)	Height (inches)	Width (inches)	Height (inches)	Width (inches)	Height (inches)	Width (inches)	Height (inches)	Width (inches)	Height (inches)	Width (inches)	Height (inches)	Width (inches)	Height (inches)	Width (inches)	Height (inches)	Width (inches)	Height (inches)	Width (inches)	Height (inches)	Width (inches)	Height (inches)	Width (inches)	Height (inches)	Width (inches)	Height (inches)	Width (inches)	Height (inches)		
Aberdeen BO (Ingenue Pearl; Effervescence; Pristine; Dulcet Graphite)	66	114	65	126	65	126	65	126	65	126	65	126	65	126	65	126	65	126	65	126	65	126	65	126	65	126	65	126	65	126	65	126	65	126
Aberdeen LF (Ingenue Pearl; Effervescence; Pristine; Dulcet Graphite)	92	127	92	137	92	137	92	137	92	137	92	137	92	137	92	137	92	137	92	137	92	137	92	137	92	137	92	137	92	137	92	137	92	137
Arboretum BO (Serene; Monarch; Sirius; Distinguished)	87	97	82	131	82	131	82	131	82	131	82	131	82	131	82	131	82	131	82	131	82	131	82	131	82	131	82	131	82	131	82	131	82	131
Arboretum LF (Serene; Monarch; Sirius; Distinguished)	90	136	90	136	90	136	90	136	90	136	90	136	90	136	90	136	90	136	90	136	90	136	90	136	90	136	90	136	90	136	90	136	90	136
Bradley (Antique Silver; Hearthstone; Midas; Azurine; Majesty; Everest)	71	85	78	121	78	121	78	121	78	121	78	121	78	121	78	121	78	121	78	121	78	121	78	121	78	121	78	121	78	121	78	121	78	121
Bravado BO (Magnolia; Elusive Ecu; Tumbled Stone; Canterbury Night)	73	93	82	125	82	125	82	125	82	125	82	125	82	125	82	125	82	125	82	125	82	125	82	125	82	125	82	125	82	125	82	125	82	125
Bravado LF (Magnolia; Elusive Ecu; Tumbled Stone; Canterbury Night)	79	113	91	133	91	133	91	133	91	133	91	133	91	133	91	133	91	133	91	133	91	133	91	133	91	133	91	133	91	133	91	133	91	133
Broadcast (Constellation; Sonnet; Casinere; Alfresco; Motti; Taliesin; Austere; Continental; Simplicity; Genuine; Gourmet; Serenade)	70	79	76	118	75	125	79	95	75	125	79	95	75	125	79	95	75	125	79	95	75	125	79	95	75	125	79	95	75	125	79	95	75	125
Cambridge LF (White; Off White; Inkwell; Clay; Hawaiian Blue; Academy; Mirage; Vernal Pond; Ivory)	94	121	94	121	94	121	94	121	94	121	94	121	94	121	94	121	94	121	94	121	94	121	94	121	94	121	94	121	94	121	94	121	94	121
Cambridge RD (Hawaiian Blue; Academy; Mirage; Vernal Pond; White; Off White; Inkwell; Clay; Ivory; Misty)	85	114	82	139	82	139	82	139	82	139	82	139	82	139	82	139	82	139	82	139	82	139	82	139	82	139	82	139	82	139	82	139	82	139
Canyon Ridge BO (Arborio Rice; Fading Nimbus; Bona Fide Taupe; Shadow Mist; Evening Storm)	65	126	65	126	65	126	65	126	65	126	65	126	65	126	65	126	65	126	65	126	65	126	65	126	65	126	65	126	65	126	65	126	65	126
Canyon Ridge LF (Arborio Rice; Fading Nimbus; Bona Fide Taupe; Shadow Mist; Evening Storm)	82	141	82	141	82	141	82	141	82	141	82	141	82	141	82	141	82	141	82	141	82	141	82	141	82	141	82	141	82	141	82	141	82	141
Chronicles (Feather; Skyline; Sunrara; Luxedo)	85	93	80	125	80	125	80	125	80	125	80	125	80	125	80	125	80	125	80	125	80	125	80	125	80	125	80	125	80	125	80	125	80	125

NOTES: Due to continuous manufacturing improvements, minimums and maximums are subject to change. Please call customer service for up to date size considerations. See dual shade section for motorization information.

12V Sonesse 28 RTS WF Ext Batt
 Minimum Width: 16"
 Minimum Height: 13"

12V Sonesse 28 RTS WF Li-ion
 Minimum Width: 24"
 Minimum Height: 13"

Features and Size Considerations

Roller and Solar Shades: 12-Volt Motor Maximum Shade Size

Valance Type	Normal Fabric Orientation												Fabric Turned Width for Height (railroaded)																			
	Small Cassette			Medium Cassette			Large Cassette/ Contour Valance/ No Cassette/ No Valance			3" Fascia			4" Fascia			Small Cassette			Medium Cassette			Large Cassette/ Contour Valance/ No Cassette/ No Valance at Maximum Width			3" Fascia			4" Fascia				
	Width (inches)	Height (inches)	Weight (inches)	Width (inches)	Height (inches)	Weight (inches)	Width (inches)	Height (inches)	Weight (inches)	Width (inches)	Height (inches)	Weight (inches)	Width (inches)	Height (inches)	Weight (inches)	Width (inches)	Height (inches)	Weight (inches)	Width (inches)	Height (inches)	Weight (inches)	Width (inches)	Height (inches)	Weight (inches)	Width (inches)	Height (inches)	Weight (inches)	Width (inches)	Height (inches)	Weight (inches)		
Cloud Frost (Fading Nimbus; Shell; Creamy Mocha)	80	120	80	120	80	120	80	120	80	120	80	120	80	120	80	120	80	120	80	120	80	120	80	120	80	120	80	120	80	120	80	120
Cloud Frost (Sea Stone)	82	102	80	120	80	120	80	120	80	120	80	120	80	120	80	120	80	120	80	120	80	120	80	120	80	120	80	120	80	120	80	120
Complex (Couture; Chance; Oceans; Visage)	71	84	77	126	77	126	77	126	80	103	77	126	80	103	77	126	80	103	77	126	80	103	77	126	80	103	77	126	80	103	77	126
Conservancy -LF (Edelweiss; Feather Grass; Golden Morel; Flowering Ash; Silver Maple; Black Peony; Sea Salt)	74	91	72	118	72	118	72	118	72	118	72	118	72	118	72	118	72	118	72	118	72	118	72	118	72	118	72	118	72	118	72	118
Conservancy-BO (Edelweiss; Feather Grass; Golden Morel; Flowering Ash; Silver Maple; Black Peony; Sea Salt)	56	87	63	114	63	114	63	114	64	103	63	114	64	103	63	114	64	103	63	114	64	103	63	114	64	103	63	114	64	103	63	114
Consummate Silk (Opalescence; Posh Platinum ; Bright Champagne; Pale Gold; Sandstone; Seafoam)	79	96	79	144	79	144	79	144	79	138	79	144	79	138	79	144	79	138	79	144	79	138	79	144	79	138	79	144	79	138	79	144
Debonair (Weekender Twill; Tan Gaberdine; Natural White; Harberdasher Gray)	92	106	89	132	89	132	89	132	89	132	89	132	89	132	89	132	89	132	89	132	89	132	89	132	89	132	89	132	89	132	89	132
Delphine BO (Mythical Gray; Evocative White; Island Paradise; Dark Earth)	72	101	82	123	82	123	82	123	82	120	82	123	82	120	82	123	82	120	82	123	82	120	82	123	82	120	82	123	82	120	82	123
Delphine LF (Mythical Gray; Evocative White; Island Paradise; Dark Earth)	94	118	94	119	94	119	94	119	94	119	94	119	94	119	94	119	94	119	94	119	94	119	94	119	94	119	94	119	94	119	94	119
Destin BO (Natural Sherpa; Glacial Gray; Silver Lining; Deep Graphite; Morning Frost; White Whimsy)	71	99	80	126	80	126	80	126	80	121	80	126	80	121	80	126	80	121	80	126	80	121	80	126	80	121	80	126	80	121	80	126
Earth Synergy (Soft Down; Wild Oats; Taupe Secret; Quarry Gray; Caviar)	85	106	82	131	82	131	82	131	82	131	82	131	82	131	82	131	82	131	82	131	82	131	82	131	82	131	82	131	82	131	82	131
EcoEncore (Mint Condition; Lunar Light; Cocoa Powder)	95	119	95	119	95	119	95	119	95	119	95	119	95	119	95	119	95	119	95	119	95	119	95	119	95	119	95	119	95	119	95	119
Ellington 1% (Tonal Taupe; Dusky Moment; Vintage Records; Georgia Brown; Misty Slate)	76	82	72	109	72	109	72	109	72	109	72	109	72	109	72	109	72	109	72	109	72	109	72	109	72	109	72	109	72	109	72	109
Ellington 3% (Tonal Taupe; Dusky Moment; Vintage Records; Georgia Brown; Misty Slate)	78	86	73	121	73	121	73	121	73	121	73	121	73	121	73	121	73	121	73	121	73	121	73	121	73	121	73	121	73	121	73	121

NOTES: Due to continuous manufacturing improvements, minimums and maximums are subject to change. Please call customer service for up to date size considerations.
 See dual shade section for motorization information.

12V Sonesse 28 RTS WF Ext Batt
 Minimum Width: 16"
 Minimum Height: 13"

12V Sonesse 28 RTS WF Li-ion
 Minimum Width: 24"
 Minimum Height: 13"

Features and Size Considerations

Roller and Solar Shades: 12-Volt Motor Maximum Shade Size

Valance Type	Normal Fabric Orientation												Fabric Turned Width for Height (railroaded)																	
	Small Cassette			Medium Cassette			Large Cassette/ Contour Valance/ No Cassette/ No Valance			3" Fascia			4" Fascia			Small Cassette			Medium Cassette			Large Cassette/ Contour Valance/ No Cassette/ No Valance			3" Fascia			4" Fascia		
	Width (inches)	Height (inches)	Width (inches)	Height (inches)	Width (inches)	Height (inches)	Width (inches)	Height (inches)	Width (inches)	Height (inches)	Width (inches)	Height (inches)	Width (inches)	Height (inches)	Width (inches)	Height (inches)	Width (inches)	Height (inches)	Width (inches)	Height (inches)	Width (inches)	Height (inches)	Width (inches)	Height (inches)	Width (inches)	Height (inches)	Width (inches)	Height (inches)	Width (inches)	Height (inches)
Ellington 5% (Tonal Taupe; Dusky Moment; Vintage Records; Georgia Brown; Misty Slate)	78	88	74	119	74	119	74	119	74	119	74	119	74	119	74	119	74	119	74	119	74	119	74	119	74	119	74	119	74	119
Emerson (Freezing Point; Khaki Stripe; Polished Pewter)	74	84	81	124	81	124	81	124	81	124	81	124	81	124	81	124	81	124	81	124	81	124	81	124	81	124	81	124	81	124
Empirical (White Shimmer; Complex Carbon; Modern Gray; Classic Khaki)	93	123	93	123	93	123	93	123	93	123	93	123	93	123	93	123	93	123	93	123	93	123	93	123	93	123	93	123	93	123
Emporium (Bookplate White)	88	120	88	124	88	124	88	124	88	124	88	124	88	124	88	124	88	124	88	124	88	124	88	124	88	124	88	124	88	124
Emporium (Silver Dollar; Vintage Letterpress; Sheet Music; Stepping Stone)	74	115	85	133	85	133	85	133	85	133	85	133	85	133	85	133	85	133	85	133	85	133	85	133	85	133	85	133	85	133
Emporium (Sepia Snapshot)	88	98	82	144	82	144	82	144	82	144	82	144	82	144	82	144	82	144	82	144	82	144	82	144	82	144	82	144	82	144
EnviroINFUSION (Calle Lilly; Modern Silver; Gray Fedora; Shoreline Sand; Column Gray; Brownstone)	94	122	94	122	94	122	94	122	94	122	94	122	94	122	94	122	94	122	94	122	94	122	94	122	94	122	94	122	94	122
Essential (Classic White; Creamy Beige; Taupe; Smokey; Black; Black on Black; Forest Green; Canyon; Beige; Stone; Black)	70	144	70	144	70	144	70	144	70	144	70	144	70	144	70	144	70	144	70	144	70	144	70	144	70	144	70	144	70	144
Exposition (Consummate; Genesis; Whistler; Resonance)	75	67	82	104	79	124	79	124	79	124	79	124	79	124	79	124	79	124	79	124	79	124	79	124	79	124	79	124	79	124
Flock BO (Skyscraper; Stallion; Evening Moonstone; Soft Beige; Brushwood)	78	51	71	89	79	120	79	120	79	120	79	120	79	120	79	120	79	120	79	120	79	120	79	120	79	120	79	120	79	120
Flock LF (Skyscraper; Stallion; Evening Moonstone; Soft Beige; Brushwood)	86	43	80	76	87	130	87	130	87	130	87	130	87	130	87	130	87	130	87	130	87	130	87	130	87	130	87	130	87	130
Gleam (Gold Rush; Ebony Glimmer; Silver Shine; Glistening Waterfall)	78	106	76	122	76	122	76	122	76	122	76	122	76	122	76	122	76	122	76	122	76	122	76	122	76	122	76	122	76	122
Guildhall (Tenor; Illusion; Montage; Armor; Mystery)	68	98	77	124	77	124	77	124	77	124	77	124	77	124	77	124	77	124	77	124	77	124	77	124	77	124	77	124	77	124
Harmonics (Titanium; Frosty White; Fossil Gray; Grounded Greige; Mannered Gold; Deep Sapphire; Modern Moss)	89	112	88	123	88	123	88	123	88	123	88	123	88	123	88	123	88	123	88	123	88	123	88	123	88	123	88	123	88	123
Harmony (Pebble ; Tassel; Marina; Shiplap; Cityscape ; Harvest; Lavender)	91	132	91	133	91	133	91	133	91	133	91	133	91	133	91	133	91	133	91	133	91	133	91	133	91	133	91	133	91	133

NOTES: Due to continuous manufacturing improvements, minimums and maximums are subject to change. Please call customer service for up to date size considerations. See dual shade section for motorization information.

12V Sonesse 28 RTS WF Ext Batt
 Minimum Width: 16"
 Minimum Height: 13"

12V Sonesse 28 RTS WF Li-ion
 Minimum Width: 24"
 Minimum Height: 13"

Features and Size Considerations

Roller and Solar Shades: 12-Volt Motor Maximum Shade Size

Valance Type	Normal Fabric Orientation										Fabric Turned Width for Height (railroaded)									
	Small Cassette		Medium Cassette		Large Cassette/ Contour Valance/ No Cassette/ No Valance		3" Fascia		4" Fascia		Small Cassette		Medium Cassette		Large Cassette/ Contour Valance/ No Cassette/ No Valance		3" Fascia		4" Fascia	
	Width (inches)	Height (inches)	Width (inches)	Height (inches)	Width (inches)	Height (inches)	Width (inches)	Height (inches)	Width (inches)	Height (inches)	Width (inches)	Height (inches)	Width (inches)	Height (inches)	Width (inches)	Height (inches)	Width (inches)	Height (inches)	Width (inches)	Height (inches)
Inkblot (Coastal Gray; Crystal; Haven; Navy Mosaic)	91	133	91	133	91	133	91	133	91	133	91	133	91	133	91	133	91	133	91	133
Jacinta (Candle Glow; Lavish Taupe; London Pewter; Greige Fusion; Charcoal)	94	125	94	125	94	125	94	125	94	125	94	125	94	125	94	125	94	125	94	125
Kindred (Endless Summer; Gilded Gray; Quarry; Ganache; City Skyline)	95	119	95	119	95	119	95	119	95	119	95	119	95	119	95	119	95	119	95	119
LiveWell (Dew Kissed; Finely Frosted; Succulent; Sandbar; Icelandic; Seaspray)	70	89	77	125	77	125	79	111	77	125	70	87	83	86	83	86	83	86	83	86
Manifest BO (Freshwater Pearl; Flint Rock; Sassy Gray; Lifting Fog; Ciabatta; Cream Filled)	82	140	82	144	82	144	82	144	82	144	NO RR	NO RR	NO RR	NO RR	NO RR	NO RR	NO RR	NO RR	NO RR	NO RR
Manifest LF (Freshwater Pearl; Flint Rock; Sassy Gray; Lifting Fog; Ciabatta; Cream Filled)	92	144	92	144	92	144	92	144	92	144	NO RR	NO RR	NO RR	NO RR	NO RR	NO RR	NO RR	NO RR	NO RR	NO RR
Mayfair (Giza Cotton; Tickled Ivory; Risotto; Silversmith; Varsity Gray; Open Seas; Mystic Meadow)	97	140	97	140	97	140	97	140	97	140	NO RR	NO RR	NO RR	NO RR	NO RR	NO RR	NO RR	NO RR	NO RR	NO RR
Merit (Clarity; Panoramic; Emulation; Atmosphere; Exquisite; Cavalier)	76	93	73	117	73	117	73	117	73	117	NO RR	NO RR	NO RR	NO RR	NO RR	NO RR	NO RR	NO RR	NO RR	NO RR
Momentum (Soft Seashell; Parisian Cream; Luxe Leather; Etched Brown; Brushed Pewter; Toasted Spice)	71	94	80	120	80	120	81	113	80	120	NO RR	NO RR	NO RR	NO RR	NO RR	NO RR	NO RR	NO RR	NO RR	NO RR
Monticello (Mist; Burro; Dune; Tikki; Rust)	73	71	80	108	78	121	84	84	78	121	73	71	83	86	83	86	84	84	83	86
Nantucket (Vintage Veil; Taupe Utopia; Rich Sable; Spice)	77	64	84	98	80	124	72	89	80	124	NO RR	NO RR	NO RR	NO RR	NO RR	NO RR	NO RR	NO RR	NO RR	NO RR
Northshore (Chai; Cream Coverlet; Safari; Fine Flint; Icy Waterfall; Lakeside)	76	111	88	128	88	128	88	128	88	128	NO RR	NO RR	NO RR	NO RR	NO RR	NO RR	NO RR	NO RR	NO RR	NO RR
Pannier (Black Dahlia; Creamy Mocha; Feather White; Riverbed Brown)	75	67	81	104	78	126	71	89	78	126	NO RR	NO RR	NO RR	NO RR	NO RR	NO RR	NO RR	NO RR	NO RR	NO RR
Paving Stone BO (Bechamel; Pale Adobe; Eventide; Almond Butter)	81	112	79	126	79	126	79	126	79	126	82	105	82	105	82	105	82	105	82	105

NOTES: Due to continuous manufacturing improvements, minimums and maximums are subject to change. Please call customer service for up to date size considerations. See dual shade section for motorization information.

12V Sonesse 28 RTS WF Ext Batt
 Minimum Width: 16"
 Minimum Height: 13"

12V Sonesse 28 RTS WF Li-ion
 Minimum Width: 24"
 Minimum Height: 13"

Features and Size Considerations

Roller and Solar Shades: 12-Volt Motor Maximum Shade Size

Valance Type	Normal Fabric Orientation												Fabric Turned Width for Height (railroaded)																					
	Small Cassette			Medium Cassette			Large Cassette/ Contour Valance/ No Cassette/ No Valance			3" Fascia			4" Fascia			Small Cassette			Medium Cassette			Large Cassette/ Contour Valance/ No Cassette/ No Valance			Large Cassette/ Contour Valance/ No Cassette/ No Valance at Maximum Width			3" Fascia			4" Fascia			
	Width (inches)	Height (inches)	Width (inches)	Height (inches)	Width (inches)	Height (inches)	Width (inches)	Height (inches)	Width (inches)	Height (inches)	Width (inches)	Height (inches)	Width (inches)	Height (inches)	Width (inches)	Height (inches)	Width (inches)	Height (inches)	Width (inches)	Height (inches)	Width (inches)	Height (inches)	Width (inches)	Height (inches)	Width (inches)	Height (inches)	Width (inches)	Height (inches)	Width (inches)	Height (inches)	Width (inches)	Height (inches)		
PlanetSafe (French Pastry; Gray Perfection; Cool Cave)	94	122	94	122	94	122	94	122	94	122	94	122	94	122	94	122	94	122	94	122	94	122	94	122	94	122	94	122	94	122	94	122	94	122
Plexus 1% (Renewal; Provisions; Chalcedony; Stately; Landmark; Travertine; Penumbra; Nutley Pier; Black Granite; Niche)	68	74	74	109	74	109	77	88	74	109	77	88	74	109	68	74	74	106	68	74	74	106	68	74	74	106	68	74	74	106	68	74	74	106
Plexus 3% (Renewal; Provisions; Chalcedony; Stately; Landmark; Travertine; Penumbra; Nutley Pier; Black Granite; Niche)	68	75	74	114	73	121	78	89	73	121	68	75	89	73	68	75	75	106	68	75	75	106	68	75	75	106	68	75	75	106	68	75	75	106
Plexus 5% (Renewal; Provisions; Chalcedony; Stately; Landmark; Travertine; Penumbra; Nutley Pier; Black Granite; Niche)	68	82	74	119	74	119	77	98	74	119	68	82	74	119	68	76	106	68	76	76	106	68	76	76	106	68	76	76	106	68	76	76	106	
Porter (Fuji Fog; Misty Marsh; Executive Gray; Rain; Classy Carbon)	68	65	75	99	73	113	64	90	73	113	64	90	73	113	64	90	73	113	64	90	73	113	64	90	73	113	64	90	73	113	64	90	73	113
Providence-BO (Vanilla Bean ; Woolen Mittens; Varsity Blue; Stacked Stone ; Golden Leaf; Dewdrop)	56	84	63	109	63	109	64	100	63	109	64	100	63	109	64	100	63	109	64	100	63	109	64	100	63	109	64	100	63	109	64	100	63	109
Providence-LF (Vanilla Bean ; Woolen Mittens; Varsity Blue; Stacked Stone ; Golden Leaf; Dewdrop)	73	93	72	110	72	110	72	110	72	110	72	110	72	110	72	110	72	110	72	110	72	110	72	110	72	110	72	110	72	110	72	110	72	110
Quintessence (White Enchantment; Flecked Gray; Gilded Linen; Gray Alloy; Black Face)	65	96	74	125	74	125	75	114	74	125	75	114	74	125	75	114	74	125	75	114	74	125	75	114	74	125	75	114	74	125	75	114	74	125
Regent (First Frost; Smoky Taupe; Fossil; Lulling Storm; Magnetic)	95	118	95	125	95	125	95	125	95	125	95	125	95	125	95	125	95	125	95	125	95	125	95	125	95	125	95	125	95	125	95	125	95	125
Renaissance (Blushed Paradise; Subdued Botanical)	92	140	92	140	92	140	92	140	92	140	92	140	92	140	92	140	92	140	92	140	92	140	92	140	92	140	92	140	92	140	92	140	92	140
Riverbend (Rust; Steel; Natural; Khaki; Maduro)	72	78	72	119	72	144	72	106	72	144	72	106	72	144	72	106	72	144	72	106	72	144	72	106	72	144	72	106	72	144	72	106	72	144
Sabine (Smooth Java; Lush Garden; Midnight Blue; Summer Gray; Powdery Sand)	84	92	79	123	79	123	79	123	79	123	79	123	79	123	79	123	79	123	79	123	79	123	79	123	79	123	79	123	79	123	79	123	79	123

NOTES: Due to continuous manufacturing improvements, minimums and maximums are subject to change. Please call customer service for up to date size considerations. See dual shade section for motorization information.

12V Sonesse 28 RTS WF Ext Batt
 Minimum Width: 16"
 Minimum Height: 13"

12V Sonesse 28 RTS WF Li-ion
 Minimum Width: 24"
 Minimum Height: 13"

Features and Size Considerations

Roller and Solar Shades: 12-Volt Motor Maximum Shade Size

Valance Type	Normal Fabric Orientation												Fabric Turned Width for Height (railroaded)																							
	Small Cassette			Medium Cassette			Large Cassette/ Valance/ No Cassette/ No Valance			3" Fascia			4" Fascia			Small Cassette			Medium Cassette			Large Cassette/ Valance/ No Cassette/ No Valance			Large Cassette/ Contour Valance/ No Cassette/ No Valance at Maximum Width			3" Fascia			4" Fascia					
	Width (inches)	Height (inches)	Width (inches)	Height (inches)	Width (inches)	Height (inches)	Width (inches)	Height (inches)	Width (inches)	Height (inches)	Width (inches)	Height (inches)	Width (inches)	Height (inches)	Width (inches)	Height (inches)	Width (inches)	Height (inches)	Width (inches)	Height (inches)	Width (inches)	Height (inches)	Width (inches)	Height (inches)	Width (inches)	Height (inches)	Width (inches)	Height (inches)	Width (inches)	Height (inches)	Width (inches)	Height (inches)				
Standard Weave 3% (Veranda; Café Doppio; Chiselec)	82	96	78	124	78	124	81	121	81	121	78	124	81	121	81	121	78	124	81	121	81	121	78	124	81	121	81	121	78	124	81	121	79	114	79	114
Standard Weave 5% (Calcite; Polished)	84	96	81	121	81	121	81	121	81	121	81	121	81	121	81	121	81	121	81	121	81	121	81	121	81	121	81	121	81	121	81	121	81	121	81	121
Standard Weave 5% (Veranda; Café Doppio; Chiselec)	82	101	80	120	80	120	80	120	80	120	80	120	80	120	80	120	80	120	80	120	80	120	80	120	80	120	80	120	80	120	80	120	80	120	80	120
Steel House (Cavern Floor; Cloud; Buff; Chocolate Souffle)	72	99	82	121	82	121	82	118	82	118	82	118	82	118	82	118	82	118	82	118	82	118	82	118	82	118	82	118	82	118	82	118	82	118	82	118
Suburban II (White; Mystic; Highland)	72	144	72	144	72	144	72	144	72	144	72	144	72	144	72	144	72	144	72	144	72	144	72	144	72	144	72	144	72	144	72	144	72	144	72	144
Tableaux (White Tranquility; Stately Gray ; Gray Opulence; Craftsman Brown; Provincial Plum; Ivory Cameo)	74	55	80	85	74	122	77	74	69	77	74	122	77	74	69	77	74	122	77	74	69	77	74	122	77	74	69	77	74	122	77	74	69	77	74	122
Tattered Husk BO (Pale Adobe; Feather White; Crystat; Polished Ore; Woven Canvas)	74	84	81	126	81	126	81	100	84	100	81	126	81	100	84	100	81	126	81	100	84	100	81	126	81	100	84	100	81	126	81	100	84	100	81	126
Tattered Husk LF (Pale Adobe; Feather White; Crystat; Polished Ore; Woven Canvas)	81	94	91	136	91	136	91	110	94	110	91	136	91	110	94	110	91	136	91	110	94	110	91	136	91	110	94	110	91	136	91	110	94	110	91	136
Terrain (Gray Frost; Pale Adobe ; Pale Rhino)	78	112	89	135	89	135	89	135	89	135	89	135	89	135	89	135	89	135	89	135	89	135	89	135	89	135	89	135	89	135	89	135	89	135	89	135
Thesis (Weathered Stone; Bluebook White; Summer Khakis; Oxford Blue; Macho Macchiato; Dusky Titanium)	70	93	70	142	70	144	70	126	70	126	70	144	70	126	70	144	70	126	70	144	70	126	70	144	70	126	70	144	70	126	70	144	70	126	70	144
Tuvalu (Misteria White; Silver Tree; Dusky Botanical)	94	121	94	121	94	121	121	121	94	121	94	121	121	121	94	121	94	121	121	121	94	121	94	121	121	121	94	121	94	121	121	121	94	121	94	121
Unison (Iglou; Malted Milk; Mascarpone; Platinum; Khaki Sand; Rivermist)	88	128	88	128	88	128	88	128	88	128	88	128	88	128	88	128	88	128	88	128	88	128	88	128	88	128	88	128	88	128	88	128	88	128	88	128
Vancouver (Meringue; Heavenly; Light Fog; Good Grayicious; Capri; Master Mariner)	91	121	90	130	90	130	90	130	90	130	90	130	90	130	90	130	90	130	90	130	90	130	90	130	90	130	90	130	90	130	90	130	90	130	90	130
Vanguard 1% (Authentic; Gentle Beige; Chrome; Pendulum)	83	89	78	124	78	124	78	124	78	124	78	124	78	124	78	124	78	124	78	124	78	124	78	124	78	124	78	124	78	124	78	124	78	124	78	124
Vanguard 1% (Elusive; Macedonia; Dew; Homage; Peloton)	82	94	77	126	77	126	77	126	77	126	77	126	77	126	77	126	77	126	77	126	77	126	77	126	77	126	77	126	77	126	77	126	77	126	77	126

NOTES: Due to continuous manufacturing improvements, minimums and maximums are subject to change. Please call customer service for up to date size considerations.
 See dual shade section for motorization information.

12V Sonesse 28 RTS WF Ext Batt
 Minimum Width: 16"
 Minimum Height: 13"

12V Sonesse 28 RTS WF Li-ion
 Minimum Width: 24"
 Minimum Height: 13"

Features and Size Considerations

Roller and Solar Shades: 12-Volt Motor Maximum Shade Size

Valance Type	Normal Fabric Orientation												Fabric Turned Width for Height (railroaded)																					
	Small Cassette			Medium Cassette			Large Cassette/ Contour Valance/ No Cassette/ No Valance			3" Fascia			4" Fascia			Small Cassette			Medium Cassette			Large Cassette/ Contour Valance/ No Cassette/ No Valance at Maximum Width			3" Fascia			4" Fascia						
	Width (inches)	Height (inches)		Width (inches)	Height (inches)		Width (inches)	Height (inches)		Width (inches)	Height (inches)		Width (inches)	Height (inches)		Width (inches)	Height (inches)		Width (inches)	Height (inches)		Width (inches)	Height (inches)		Width (inches)	Height (inches)		Width (inches)	Height (inches)		Width (inches)	Height (inches)		
Vanguard 3% (Authentic; Gentle Beige; Chrome; Pendulum)	83	96	80	120	80	120	80	120	80	120	80	120	80	120	83	96	81	113	81	113	81	113	81	113	81	113	81	113	81	113	81	113	81	113
Vanguard 3% (Elusive; Macedonia; Dew; Homage; Peloton)	82	96	78	124	78	124	78	124	78	124	78	124	78	124	82	96	79	114	79	114	79	114	79	114	79	114	79	114	79	114	79	114	79	114
Vanguard 5% (Authentic; Gentle Beige; Chrome; Pendulum)	84	96	81	121	81	121	81	121	81	121	81	121	81	121	84	96	82	114	82	114	82	114	82	114	82	114	82	114	82	114	82	114	82	114
Vanguard 5% (Elusive; Macedonia; Dew; Homage; Peloton)	82	101	80	120	80	120	80	120	80	120	80	120	80	120	82	101	81	113	81	113	81	113	81	113	81	113	81	113	81	113	81	113	81	113
Wayfarer (Sultry White; Maldives Gray)	92	144	92	144	92	144	92	144	92	144	92	144	92	144	NO RR	NO RR	NO RR	NO RR	NO RR	NO RR	NO RR	NO RR	NO RR	NO RR	NO RR	NO RR	NO RR	NO RR	NO RR	NO RR	NO RR	NO RR	NO RR	
Whitcomb (Paloverde; Invitation; Juniper)	90	118	89	132	89	132	89	132	89	132	89	132	89	132	NO RR	NO RR	NO RR	NO RR	NO RR	NO RR	NO RR	NO RR	NO RR	NO RR	NO RR	NO RR	NO RR	NO RR	NO RR	NO RR	NO RR	NO RR	NO RR	NO RR
Whitehall (Veranda; Wolverine; Nectar; Westminster; Seattle Mist)	87	106	82	144	82	144	82	144	82	144	82	144	82	144	87	106	87	108	87	108	87	108	87	108	87	108	87	108	87	108	87	108	87	108
Whittaker BO (Sugar Quartz; Inspired Ivory; Orion; Gray Frost; Scone; Night Life)	73	87	81	122	81	122	81	122	81	122	81	122	81	122	NO RR	NO RR	NO RR	NO RR	NO RR	NO RR	NO RR	NO RR	NO RR	NO RR	NO RR	NO RR	NO RR	NO RR	NO RR	NO RR	NO RR	NO RR	NO RR	NO RR

NOTES: Due to continuous manufacturing improvements, minimums and maximums are subject to change. Please call customer service for up to date size considerations. See dual shade section for motorization information.

Features and Size Considerations

12V Sonesse 30 Ultra RTS WF Li-ion **24V RTS SON30**
 Minimum Width: 30 Minimum Width: 20"
 Minimum Height: 13" Minimum Height: 13"

Roller and Solar Shades: Motor: Maximum Shade Size

Valance Type	Normal Fabric Orientation												Fabric Turned Width for Height (railroaded)																												
	Small Cassette			Medium Cassette			Large Cassette/ Contour Valance/ No Cassette/ No Valance			4" Fascia			3" Fascia			Medium Cassette			Large Cassette/ Contour Valance/ No Cassette/ No Valance			Large Cassette/ Contour Valance/ No Cassette/ No Valance at Maximum Width			3" Fascia			4" Fascia													
	Width (Inches)	Height (Inches)	Width (Inches)	Height (Inches)	Width (Inches)	Height (Inches)	Width (Inches)	Height (Inches)	Width (Inches)	Height (Inches)	Width (Inches)	Height (Inches)	Width (Inches)	Height (Inches)	Width (Inches)	Height (Inches)	Width (Inches)	Height (Inches)	Width (Inches)	Height (Inches)	Width (Inches)	Height (Inches)	Width (Inches)	Height (Inches)	Width (Inches)	Height (Inches)	Width (Inches)	Height (Inches)	Width (Inches)	Height (Inches)	Width (Inches)	Height (Inches)									
Ellington 3% (Tonal Taupe; Dusky Moment; Vintage Records; Georgia Brown; Misty Slate)	78	86	101	111	98	130	73	121	98	130	73	121	98	130	86	111	101	111	101	111	101	111	101	111	101	111	74	113	101	111	74	113	101	111							
Ellington 5% (Tonal Taupe; Dusky Moment; Vintage Records; Georgia Brown; Misty Slate)	78	88	101	112	97	144	74	119	97	144	74	119	97	144	NO RR	NO RR	NO RR	NO RR	NO RR	NO RR	NO RR	NO RR	NO RR	NO RR	NO RR	NO RR	NO RR	NO RR	NO RR	NO RR	NO RR	NO RR	NO RR	NO RR							
Emerson (Freezing Point; Khaki Stripe; Poised Pewter)	90	68	81	124	109	133	84	100	109	133	84	100	109	133	NO RR	NO RR	NO RR	NO RR	NO RR	NO RR	NO RR	NO RR	NO RR	NO RR	NO RR	NO RR	NO RR	NO RR	NO RR	NO RR	NO RR	NO RR	NO RR	NO RR	NO RR						
Empirical (White Shimmer; Complex Carbon; Modern Gray; Classic Khaki)	93	123	96	144	96	144	96	144	96	144	96	144	96	144	NO RR	NO RR	NO RR	NO RR	NO RR	NO RR	NO RR	NO RR	NO RR	NO RR	NO RR	NO RR	NO RR	NO RR	NO RR	NO RR	NO RR	NO RR	NO RR	NO RR	NO RR	NO RR					
Emporium (Bookplate White)	88	120	96	144	96	144	96	106	96	144	96	106	96	144	NO RR	NO RR	NO RR	NO RR	NO RR	NO RR	NO RR	NO RR	NO RR	NO RR	NO RR	NO RR	NO RR	NO RR	NO RR	NO RR	NO RR	NO RR	NO RR	NO RR	NO RR	NO RR					
Emporium (Silver Dollar; Vintage Letterpress; Sheet Music; Stepping Stone)	89	98	96	125	96	144	85	133	96	144	85	133	96	144	NO RR	NO RR	NO RR	NO RR	NO RR	NO RR	NO RR	NO RR	NO RR	NO RR	NO RR	NO RR	NO RR	NO RR	NO RR	NO RR	NO RR	NO RR	NO RR	NO RR	NO RR	NO RR	NO RR				
Emporium (Sepia Snapshot)	88	98	96	125	96	144	82	141	96	144	82	141	96	144	NO RR	NO RR	NO RR	NO RR	NO RR	NO RR	NO RR	NO RR	NO RR	NO RR	NO RR	NO RR	NO RR	NO RR	NO RR	NO RR	NO RR	NO RR	NO RR	NO RR	NO RR	NO RR	NO RR				
EnviroINFUSION (Calle Lilly; Modern Silver; Gray Fedora; Shoreline Sand; Column Gray; Brownstone)	94	122	115	144	115	144	115	127	115	144	115	127	115	144	NO RR	NO RR	NO RR	NO RR	NO RR	NO RR	NO RR	NO RR	NO RR	NO RR	NO RR	NO RR	NO RR	NO RR	NO RR	NO RR	NO RR	NO RR	NO RR	NO RR	NO RR	NO RR	NO RR	NO RR			
Essential (Classic White; Creamy Beige; Taupe; Smokey; Black; Black on Black; Forest Green; Canyon; Beige; Stone; Black)	70	144	70	144	70	144	70	144	70	144	70	144	70	144	91	60	91	60	91	60	91	60	91	60	91	60	123	57	91	60	123	57	91	60	123	57	91	60			
Exposition (Consummate; Genesis; Wishlist; Resonance)	92	54	82	104	96	144	86	80	96	144	86	80	96	144	NO RR	NO RR	NO RR	NO RR	NO RR	NO RR	NO RR	NO RR	NO RR	NO RR	NO RR	NO RR	NO RR	NO RR	NO RR	NO RR	NO RR	NO RR	NO RR	NO RR	NO RR	NO RR	NO RR	NO RR	NO RR		
Flock BO (Skyscraper; Stallion; Evening Moonstone; Soft Beige; Brushwood)	95	40	86	78	106	131	90	60	108	116	90	60	108	116	NO RR	NO RR	NO RR	NO RR	NO RR	NO RR	NO RR	NO RR	NO RR	NO RR	NO RR	NO RR	NO RR	NO RR	NO RR	NO RR	NO RR	NO RR	NO RR	NO RR	NO RR	NO RR	NO RR	NO RR	NO RR	NO RR	
Flock LF (Skyscraper; Stallion; Evening Moonstone; Soft Beige; Brushwood)	103	33	96	67	108	129	99	51	88	122	99	51	88	122	NO RR	NO RR	NO RR	NO RR	NO RR	NO RR	NO RR	NO RR	NO RR	NO RR	NO RR	NO RR	NO RR	NO RR	NO RR	NO RR	NO RR	NO RR	NO RR	NO RR	NO RR	NO RR	NO RR	NO RR	NO RR	NO RR	
Gleam (Gold Rush; Ebony Glimmer; Silver Shine; Glistening Waterfall)	78	106	92	136	92	144	76	122	92	144	76	122	92	144	NO RR	NO RR	NO RR	NO RR	NO RR	NO RR	NO RR	NO RR	NO RR	NO RR	NO RR	NO RR	NO RR	NO RR	NO RR	NO RR	NO RR	NO RR	NO RR	NO RR	NO RR	NO RR	NO RR	NO RR	NO RR	NO RR	NO RR
Guilchall (Tenor; Illusion; Montage; Armor; Mystery)	84	80	96	102	96	144	78	116	96	144	78	116	96	144	NO RR	NO RR	NO RR	NO RR	NO RR	NO RR	NO RR	NO RR	NO RR	NO RR	NO RR	NO RR	NO RR	NO RR	NO RR	NO RR	NO RR	NO RR	NO RR	NO RR	NO RR	NO RR	NO RR	NO RR	NO RR	NO RR	NO RR

NOTES: Due to continuous manufacturing improvements, minimums and maximums are subject to change. Please call customer service for up to date size considerations.

Features and Size Considerations

12V Sonesse 30 Ultra RTS WF Li-ion **24V RTS SON30**
 Minimum Width: 30 Minimum Width: 20"
 Minimum Height: 13 Minimum Height: 13"

Roller and Solar Shades: Motor: Maximum Shade Size

Valance Type	Normal Fabric Orientation												Fabric Turned Width for Height (railroaded)																	
	Small Cassette			Medium Cassette			Large Cassette/ Contour Valance/ No Valance			3" Fascia			4" Fascia			Small Cassette			Medium Cassette			Large Cassette/ Contour Valance/ No Cassette/ No Valance at Maximum Width			3" Fascia			4" Fascia		
	Width (inches)	Height (inches)	Weight (inches)	Width (inches)	Height (inches)	Weight (inches)	Width (inches)	Height (inches)	Weight (inches)	Width (inches)	Height (inches)	Weight (inches)	Width (inches)	Height (inches)	Weight (inches)	Width (inches)	Height (inches)	Weight (inches)	Width (inches)	Height (inches)	Weight (inches)	Width (inches)	Height (inches)	Weight (inches)	Width (inches)	Height (inches)	Weight (inches)	Width (inches)	Height (inches)	Weight (inches)
Northshore (Chai; Cream Coverlet; Safari; Fine Flint; Icy Waterfall; Lakeside)	93	91	115	117	144	88	128	115	144	144	88	128	115	144	144	88	128	115	144	144	88	128	115	144	144	88	128	115	144	144
Panner (Black Dahlia; Creamy Mocha; Feather White; Riverbed Brown)	91	54	81	104	144	85	80	96	144	144	85	80	96	144	144	85	80	96	144	144	85	80	96	144	144	85	80	96	144	144
Paving Stone BO (Bechamel; Pale Adobe; Eventide; Almond Butter)	81	112	107	131	131	113	98	107	131	131	113	98	107	131	131	113	98	107	131	131	113	98	107	131	131	113	98	107	131	131
PlanetSafe (French Pastry; Gray Perfection; Cool Cave)	94	122	103	144	144	103	144	103	144	144	103	144	103	144	144	103	144	103	144	144	103	144	103	144	144	103	144	103	144	144
Plexus 1% (Renewal; Provisions; Chalcedony; Stately; Landmark; Travertine; Penumbra; Nutley Pier; Black Granite; Niche)	84	60	74	109	134	77	88	97	134	134	77	88	97	134	134	77	88	97	134	134	77	88	97	134	134	77	88	97	134	134
Plexus 3% (Renewal; Provisions; Chalcedony; Stately; Landmark; Travertine; Penumbra; Nutley Pier; Black Granite; Niche)	84	61	74	114	135	78	89	98	135	135	78	89	98	135	135	78	89	98	135	135	78	89	98	135	135	78	89	98	135	135
Plexus 5% (Renewal; Provisions; Chalcedony; Stately; Landmark; Travertine; Penumbra; Nutley Pier; Black Granite; Niche)	84	67	74	119	134	77	98	99	134	134	77	98	99	134	134	77	98	99	134	134	77	98	99	134	134	77	98	99	134	134
Porter (Fuji Fog; Misty Marsh; Executive Gray; Rain; Classy Carbon)	84	52	75	99	136	78	77	96	136	136	78	77	96	136	136	78	77	96	136	136	78	77	96	136	136	78	77	96	136	136
Providence-BO (Vanilla Bean ; Woolen Mittens; Varsity Blue; Stacked Stone ; Golden Leaf; Dewdrop)	69	68	89	87	138	64	100	82	138	138	64	100	82	138	138	64	100	82	138	138	64	100	82	138	138	64	100	82	138	138
Providence-LF (Vanilla Bean ; Woolen Mittens; Varsity Blue; Stacked Stone ; Golden Leaf; Dewdrop)	73	93	95	119	123	72	110	95	123	123	72	110	95	123	123	72	110	95	123	123	72	110	95	123	123	72	110	95	123	123
Quintessence (White Enchantment; Flecked Gray; Gilded Linen; Gray Alloy; Black Face)	80	78	104	100	144	75	114	98	144	144	75	114	98	144	144	75	114	98	144	144	75	114	98	144	144	75	114	98	144	144

NOTES: Due to continuous manufacturing improvements, minimums and maximums are subject to change. Please call customer service for up to date size considerations.

Features and Size Considerations

12V Sonesse 30 Ultra RTS WF Li-ion **24V RTS SON30**
 Minimum Width: 30 Minimum Width: 20"
 Minimum Height: 13 Minimum Height: 13"

Roller and Solar Shades: Motor: Maximum Shade Size

Valance Type	Normal Fabric Orientation												Fabric Turned Width for Height (railroaded)																						
	Small Cassette			Medium Cassette			Large Cassette/ Contour Valance/ No Cassette/ No Valance			3" Fascia			4" Fascia			Small Cassette			Medium Cassette			Large Cassette/ Contour Valance/ No Cassette/ No Valance			Large Cassette/ Contour Valance/ No Cassette/ No Valance at Maximum Width			3" Fascia			4" Fascia				
	Width (inches)	Height (inches)	Width (inches)	Height (inches)	Width (inches)	Height (inches)	Width (inches)	Height (inches)	Width (inches)	Height (inches)	Width (inches)	Height (inches)	Width (inches)	Height (inches)	Width (inches)	Height (inches)	Width (inches)	Height (inches)	Width (inches)	Height (inches)	Width (inches)	Height (inches)	Width (inches)	Height (inches)	Width (inches)	Height (inches)	Width (inches)	Height (inches)	Width (inches)	Height (inches)	Width (inches)	Height (inches)	Width (inches)	Height (inches)	
Standard Weave 1% (Calcite; Polished)	83	89	108	114	106	129	129	78	124	106	129	129	83	89	109	111	109	111	109	111	109	111	109	111	80	111	109	111	80	111	109	111	109	111	
Standard Weave 1% (Veranda; Café Doppio; Chiseled)	82	94	106	121	102	144	144	77	126	102	144	144	82	94	108	111	108	111	108	111	108	111	108	111	79	112	108	111	79	112	108	111	108	111	
Standard Weave 10% (Calcite; Polished)	84	106	110	134	108	144	144	82	124	108	144	144	84	106	115	103	115	103	115	103	115	103	115	103	84	106	115	103	84	106	115	103	115	103	
Standard Weave 10% (Veranda; Café Doppio; Chiseled)	84	101	108	130	108	135	135	81	121	108	135	135	84	101	113	103	113	103	113	103	113	103	113	103	83	106	113	103	83	106	113	103	113	103	
Standard Weave 3% (Calcite; Polished)	83	96	108	123	107	133	133	80	120	107	133	133	83	96	110	111	110	111	110	111	110	111	110	111	81	113	110	111	81	113	110	111	110	111	
Standard Weave 3% (Veranda; Café Doppio; Chiseled)	82	96	107	122	106	128	128	78	124	106	128	128	82	96	109	111	109	111	109	111	109	111	109	111	79	114	109	111	79	114	109	111	109	111	
Standard Weave 5% (Calcite; Polished)	84	96	110	123	108	135	135	81	121	108	135	135	84	96	112	111	112	111	112	111	112	111	112	111	82	114	112	111	82	114	112	111	112	111	
Standard Weave 5% (Veranda; Café Doppio; Chiseled)	82	101	108	127	107	133	133	80	120	107	133	133	82	101	110	111	110	111	110	111	110	111	110	111	81	113	110	111	81	113	110	111	110	111	
Steel House (Cavern Floor; Cloud; Buff; Chocolate Souffle)	88	81	82	121	96	144	144	82	118	96	144	144	NO RR	NO RR	NO RR	NO RR	NO RR	NO RR	NO RR	NO RR	NO RR	NO RR	NO RR	NO RR	NO RR	NO RR	NO RR	NO RR	NO RR	NO RR	NO RR	NO RR	NO RR	NO RR	NO RR
Suburban II (White; Mystic; Highland)	72	144	72	144	72	144	144	72	144	72	144	144	100	62	100	62	100	62	100	62	100	62	100	62	133	59	100	62	100	62	100	62	100	62	
Tableaux (White Tranquility; Stately Gray; Gray Opulence; Craftsman Brown; Provincial Plum; Ivory Cameo)	91	43	80	85	96	144	144	84	65	96	125	125	NO RR	NO RR	NO RR	NO RR	NO RR	NO RR	NO RR	NO RR	NO RR	NO RR	NO RR	NO RR	NO RR	NO RR	NO RR	NO RR	NO RR	NO RR	NO RR	NO RR	NO RR	NO RR	NO RR
Tattered Husk BO (Pale Adobe; Feather White; Crystal; Polished Ore; Woven Canvas)	90	68	81	126	109	135	135	84	100	109	135	135	NO RR	NO RR	NO RR	NO RR	NO RR	NO RR	NO RR	NO RR	NO RR	NO RR	NO RR	NO RR	NO RR	NO RR	NO RR	NO RR	NO RR	NO RR	NO RR	NO RR	NO RR	NO RR	NO RR
Tattered Husk LF (Pale Adobe; Feather White; Crystal; Polished Ore; Woven Canvas)	98	76	91	136	108	144	144	94	110	108	144	144	NO RR	NO RR	NO RR	NO RR	NO RR	NO RR	NO RR	NO RR	NO RR	NO RR	NO RR	NO RR	NO RR	NO RR	NO RR	NO RR	NO RR	NO RR	NO RR	NO RR	NO RR	NO RR	NO RR
Terrain (Gray Frost; Pale Adobe; Pale Rhino)	94	93	106	119	106	144	144	89	135	106	144	144	NO RR	NO RR	NO RR	NO RR	NO RR	NO RR	NO RR	NO RR	NO RR	NO RR	NO RR	NO RR	NO RR	NO RR	NO RR	NO RR	NO RR	NO RR	NO RR	NO RR	NO RR	NO RR	NO RR
Thesis (Weathered Stone; Bluebook White; Summer Khakis; Oxford Blue; Macho Macchiato; Dusky Titanium)	70	76	70	142	70	144	144	70	111	70	144	144	NO RR	NO RR	NO RR	NO RR	NO RR	NO RR	NO RR	NO RR	NO RR	NO RR	NO RR	NO RR	NO RR	NO RR	NO RR	NO RR	NO RR	NO RR	NO RR	NO RR	NO RR	NO RR	NO RR
Tuvalu (Wisteria White; Silver Tree; Dusky Botanical)	94	121	106	144	106	144	144	106	111	106	144	144	NO RR	NO RR	NO RR	NO RR	NO RR	NO RR	NO RR	NO RR	NO RR	NO RR	NO RR	NO RR	NO RR	NO RR	NO RR	NO RR	NO RR	NO RR	NO RR	NO RR	NO RR	NO RR	NO RR
Unison (Igloo; Malted Milk; Mascarpone; Platinum; Khaki Sand; Rivermist)	88	128	115	144	115	144	144	115	118	115	144	144	NO RR	NO RR	NO RR	NO RR	NO RR	NO RR	NO RR	NO RR	NO RR	NO RR	NO RR	NO RR	NO RR	NO RR	NO RR	NO RR	NO RR	NO RR	NO RR	NO RR	NO RR	NO RR	NO RR

NOTES: Due to continuous manufacturing improvements, minimums and maximums are subject to change. Please call customer service for up to date size considerations.

Features and Size Considerations

120-Volt RTS
 Minimum Width: 24.5"
 Minimum Height: 13"

120-Volt Standard
 Minimum Width: 23"
 Minimum Height: 13"

Roller and Solar Shades: 120-Volt Motor Maximum Shade Size (120V RTS ST40 Motor or 120V STD ST40 Motor)

Valance Type	Normal Fabric Orientation												Fabric Turned Width for Height (railroaded)											
	Contour Valance/ No Valance				3" Fascia				4" Fascia				Contour Valance/ No Valance				3" Fascia				4" Fascia			
	Width (inches)	Height (inches)	Width (inches)	Height (inches)	Width (inches)	Height (inches)	Width (inches)	Height (inches)	Width (inches)	Height (inches)	Width (inches)	Height (inches)	Width (inches)	Height (inches)	Width (inches)	Height (inches)	Width (inches)	Height (inches)	Width (inches)	Height (inches)	Width (inches)	Height (inches)	Width (inches)	Height (inches)
Aberdeen BO(Ingenue Pearl; Effervescence; Pristine; Dulcet Graphite)	92	144	91	101	92	144	92	144	NO RR	NO RR	NO RR	NO RR	NO RR	NO RR	NO RR	NO RR	NO RR	NO RR	NO RR	NO RR	NO RR	NO RR	NO RR	NO RR
Aberdeen LF(Ingenue Pearl; Effervescence; Pristine; Dulcet Graphite)	92	144	92	113	92	144	92	144	131	79	131	79	144	76	131	79	144	76	131	79	131	79	144	79
Arboretum BO(Serene; Monarch; Sirius; Distinguished)	92	144	92	85	92	144	92	144	121	79	121	79	144	76	121	79	144	76	121	79	121	79	144	79
Arboretum LF(Serene; Monarch; Sirius; Distinguished)	92	144	92	125	92	144	92	144	129	79	129	79	144	76	129	79	144	76	129	79	129	79	144	79
Bradley(Antique Silver; Hearststone; Midas; Azurine; Majesty; Everest)	96	144	96	60	96	144	96	144	NO RR	NO RR	NO RR	NO RR	NO RR	NO RR	NO RR	NO RR	NO RR	NO RR	NO RR	NO RR	NO RR	NO RR	NO RR	NO RR
Bravado BO(Magnolia; Elusive Ecru; Tumbled Stone; Canterbury Night)	109	144	109	66	108	144	108	144	NO RR	NO RR	NO RR	NO RR	NO RR	NO RR	NO RR	NO RR	NO RR	NO RR	NO RR	NO RR	NO RR	NO RR	NO RR	NO RR
Bravado LF(Magnolia; Elusive Ecru; Tumbled Stone; Canterbury Night)	109	144	109	81	109	144	109	144	NO RR	NO RR	NO RR	NO RR	NO RR	NO RR	NO RR	NO RR	NO RR	NO RR	NO RR	NO RR	NO RR	NO RR	NO RR	NO RR
Broadcast(Constellation; Sonnet; Cashmere; Alfresco; Motif; Talesin; Austere; Continental; Simplicity; Genuine; Gourmet; Serenade)	116	144	116	56	116	120	116	120	144	100	144	100	144	100	119	56	144	100	119	56	144	100	144	100
Cambridge LF(White; Off White; Inkwell; Clay; Hawaiian Blue; Academy; Mirage; Vernal Pond; Ivory)	119	144	119	132	119	144	119	144	127	107	127	107	144	103	127	107	144	103	127	107	127	107	144	107
Cambridge RD(Hawaiian Blue; Academy; Mirage; Vernal Pond; White; Off White; Inkwell ; Clay ; Ivory; Misty)	117	144	117	100	117	144	117	144	117	105	117	105	144	101	118	100	144	101	118	100	117	105	144	105
Canyon Ridge BO(Arborio Rice; Fading Nimbus; Bona Fide Taupe; Shadow Mist; Evening Storm)	92	144	89	117	92	144	92	144	NO RR	NO RR	NO RR	NO RR	NO RR	NO RR	NO RR	NO RR	NO RR	NO RR	NO RR	NO RR	NO RR	NO RR	NO RR	NO RR
Canyon Ridge LF(Arborio Rice; Fading Nimbus; Bona Fide Taupe; Shadow Mist; Evening Storm)	92	144	92	132	92	144	92	144	116	79	116	79	144	76	116	79	144	76	116	79	116	79	144	79
Chronicles(Feather; Skyline; Sumatra; Tuxedo)	96	144	96	81	96	144	96	144	NO RR	NO RR	NO RR	NO RR	NO RR	NO RR	NO RR	NO RR	NO RR	NO RR	NO RR	NO RR	NO RR	NO RR	NO RR	NO RR
Cloud Frost(Fading Nimbus; Shell; Creamy Mocha)	119	144	107	124	119	144	119	144	NO RR	NO RR	NO RR	NO RR	NO RR	NO RR	NO RR	NO RR	NO RR	NO RR	NO RR	NO RR	NO RR	NO RR	NO RR	NO RR
Cloud Frost(Sea Stone)	119	144	111	91	119	144	119	144	NO RR	NO RR	NO RR	NO RR	NO RR	NO RR	NO RR	NO RR	NO RR	NO RR	NO RR	NO RR	NO RR	NO RR	NO RR	NO RR
Complex(Couture; Chance; Oceans; Visage)	96	144	96	61	96	144	96	144	NO RR	NO RR	NO RR	NO RR	NO RR	NO RR	NO RR	NO RR	NO RR	NO RR	NO RR	NO RR	NO RR	NO RR	NO RR	NO RR
Conservancy - LF(Edelweiss; Feather Grass; Golden Morel; Flowering Ash; Silver Maple; Black Peony; Sea Salt)	115	144	100	80	115	144	115	144	NO RR	NO RR	NO RR	NO RR	NO RR	NO RR	NO RR	NO RR	NO RR	NO RR	NO RR	NO RR	NO RR	NO RR	NO RR	NO RR

NOTES: Due to continuous manufacturing improvements, minimums and maximums are subject to change. Please call customer service for up to date size considerations.

Features and Size Considerations

120-Volt RTS
 Minimum Width: 24.5"
 Minimum Height: 13"

120-Volt Standard
 Minimum Width: 23"
 Minimum Height: 13"

Roller and Solar Shades: 120-Volt Motor Maximum Shade Size (120V RTS ST40 Motor or 120V STD ST40 Motor)

Valance Type	Normal Fabric Orientation						Fabric Turned Width for Height (railroaded)					
	Contour Valance/ No Valance		3" Fascia		4" Fascia		Contour Valance/ No Valance		3" Fascia		4" Fascia	
	Width (inches)	Height (inches)	Width (inches)	Height (inches)	Width (inches)	Height (inches)	Width (inches)	Height (inches)	Width (inches)	Height (inches)	Width (inches)	Height (inches)
Conservancy-BO(Edelweiss; Feather Grass; Golden Morel; Flowering Ash; Silver Maple; Black Peony; Sea Salt)	110	144	95	61	111	130	NO RR	NO RR	NO RR	NO RR	NO RR	NO RR
Consummate Silk(Opalescence; Posh Platinum; Bright Champagne; Pale Gold; Sandstone; Seafoam)	79	144	79	84	79	144	NO RR	NO RR	NO RR	NO RR	NO RR	NO RR
Debonair(Weekender Twill; Tan Gaberdine; Natural White; Harberdasher Gray)	106	144	106	93	106	144	NO RR	NO RR	NO RR	NO RR	NO RR	NO RR
Delphine BO(Mythical Gray; Evocative White; Island Paradise; Dark Earth)	109	144	109	72	109	144	NO RR	NO RR	NO RR	NO RR	NO RR	NO RR
Delphine LF(Mythical Gray; Evocative White; Island Paradise; Dark Earth)	108	144	108	104	108	144	NO RR	NO RR	NO RR	NO RR	NO RR	NO RR
Destin BO(Natural Sherpa; Glacial Gray; Silver Lining; Deep Graphite; Morning Frost; White Whimsy)	113	144	113	72	113	144	NO RR	NO RR	NO RR	NO RR	NO RR	NO RR
Earth Synergy(Soft Down; Wild Oats; Taupe Secret; Quarry Gray; Cavalier)	116	144	116	93	116	144	NO RR	NO RR	NO RR	NO RR	NO RR	NO RR
EcoEncore (Mint Condition; Lunar Light; Cocoa Powder)	100	144	100	144	100	144	NO RR	NO RR	NO RR	NO RR	NO RR	NO RR
Ellington 1%(Tonal Taupe; Dusky Moment; Vintage Records; Georgia Brown; Misty Slate)	124	144	106	71	124	144	131	108	106	71	131	108
Ellington 3%(Tonal Taupe; Dusky Moment; Vintage Records; Georgia Brown; Misty Slate)	124	144	107	75	124	144	134	108	107	75	134	108
Ellington 5%(Tonal Taupe; Dusky Moment; Vintage Records; Georgia Brown; Misty Slate)	124	144	108	77	124	144	NO RR	NO RR	NO RR	NO RR	NO RR	NO RR
Emerson(Freezing Point; Khaki Stripe; Poised Pewter)	117	144	117	59	117	126	NO RR	NO RR	NO RR	NO RR	NO RR	NO RR
Empirical(White Shimmer; Complex Carbon; Modern Gray; Classic Khaki)	96	144	96	144	96	144	NO RR	NO RR	NO RR	NO RR	NO RR	NO RR
Emporium(Bookplate White)	96	144	96	106	96	144	NO RR	NO RR	NO RR	NO RR	NO RR	NO RR
Emporium(Silver Dollar; Vintage Letterpress; Sheet Music; Stepping Stone)	96	144	96	86	96	144	NO RR	NO RR	NO RR	NO RR	NO RR	NO RR
Emporium(Sepia Snapshot)	96	144	96	86	96	144	NO RR	NO RR	NO RR	NO RR	NO RR	NO RR
EnviroINFUSION(Calle Lilly; Modern Silver; Gray Fedora; Shoreline Sand; Column Gray; Brownstone)	115	144	115	127	115	144	NO RR	NO RR	NO RR	NO RR	NO RR	NO RR

NOTES: Due to continuous manufacturing improvements, minimums and maximums are subject to change. Please call customer service for up to date size considerations.

Features and Size Considerations

120-Volt RTS

Minimum Width: 24.5"
Minimum Height: 13"

120-Volt Standard

Minimum Width: 23"
Minimum Height: 13"

Roller and Solar Shades: 120-Volt Motor Maximum Shade Size (120V RTS ST40 Motor or 120V STD ST40 Motor)

Valance Type	Normal Fabric Orientation												Fabric Turned Width for Height (railroaded)					
	Contour Valance/ No Valance			3" Fascia			4" Fascia			Contour Valance/ No Valance			3" Fascia			4" Fascia		
	Width (inches)	Height (inches)		Width (inches)	Height (inches)		Width (inches)	Height (inches)		Width (inches)	Height (inches)		Width (inches)	Height (inches)		Width (inches)	Height (inches)	
Essential(Classic White; Creamy Beige; Taupe; Smokey; Black; Black on Black; Forest Green; Canyon; Beige; Stone; Black)	70	144		70	144		70	144		123	57		123	57		123	57	
Exposition(Consummate; Genesis; Wishlist; Resonance)	96	144		96	46		96	144		NO RR	NO RR		NO RR	NO RR		NO RR	NO RR	
Flock BO(Skyscraper; Stallion; Evening Moonstone; Soft Beige; Brushwood)	106	131		108	33		108	116		NO RR	NO RR		NO RR	NO RR		NO RR	NO RR	
Flock LF(Skyscraper; Stallion; Evening Moonstone; Soft Beige; Brushwood)	108	129		108	27		108	99		NO RR	NO RR		NO RR	NO RR		NO RR	NO RR	
Gleam(Gold Rush; Ebony Glimmer; Silver Shine; Glistening Waterfall)	92	144		92	94		92	144		NO RR	NO RR		NO RR	NO RR		NO RR	NO RR	
Guildhall(Tenor; Illusion; Montage; Armor; Mystery)	96	144		96	69		96	144		NO RR	NO RR		NO RR	NO RR		NO RR	NO RR	
Harmonics(Titanium; Frosty White; Fossil Gray; Grounded Greige; Mannered Gold; Deep Sapphire; Modern Moss)	115	144		115	98		115	144		NO RR	NO RR		NO RR	NO RR		NO RR	NO RR	
Harmony(Pebble ; Tassel; Marina; Shiplap; Cityscape ; Harvest; Lavender)	119	144		119	117		119	144		NO RR	NO RR		NO RR	NO RR		NO RR	NO RR	
Inklot(Coastal Gray; Crystal; Haven; Navy Mosaic)	119	144		119	126		119	144		NO RR	NO RR		NO RR	NO RR		NO RR	NO RR	
Jacinta(Candle Glow; Lavish Taupe; London Pewter; Greige Fusion; Charcoal)	112	144		112	125		112	144		NO RR	NO RR		NO RR	NO RR		NO RR	NO RR	
Kindred(Endless Summer; Gilded Gray; Quarry; Ganache; City Skyline)	112	144		112	110		112	144		NO RR	NO RR		NO RR	NO RR		NO RR	NO RR	
LiveWell(Dew Kissed; Finely Frosted; Succulent; Sandbar; Icelandic; Seaspray)	95	144		95	66		95	144		114	83		144	79		114	83	
Manifest BO(Freshwater Pearl; Flint Rock; Savvy Gray; Lifting Fog; Ciabatta; Cream Filled)	92	144		92	124		92	144		NO RR	NO RR		NO RR	NO RR		NO RR	NO RR	
Manifest LF(Freshwater Pearl; Flint Rock; Savvy Gray; Lifting Fog; Ciabatta; Cream Filled)	92	144		92	144		92	144		NO RR	NO RR		NO RR	NO RR		NO RR	NO RR	
Mayfair(Giza Cotton; Tinkled Ivory; Risotto; Silversmith; Varsity Gray; Open Seas; Mystic Meadow)	107	144		107	136		107	144		NO RR	NO RR		NO RR	NO RR		NO RR	NO RR	
Merit(Clarity; Panoramic; Emulation; Atmosphere; Exquisite; Cavalier)	96	144		96	81		96	144		NO RR	NO RR		NO RR	NO RR		NO RR	NO RR	

NOTES: Due to continuous manufacturing improvements, minimums and maximums are subject to change. Please call customer service for up to date size considerations.

Features and Size Considerations

120-Volt RTS
 Minimum Width: 24.5"
 Minimum Height: 13"

120-Volt Standard
 Minimum Width: 23"
 Minimum Height: 13"

Roller and Solar Shades: 120-Volt Motor Maximum Shade Size (120V RTS ST40 Motor or 120V STD ST40 Motor)

Valance Type	Normal Fabric Orientation						Fabric Turned Width for Height (railroaded)					
	Contour Valance/ No Valance		3" Fascia		4" Fascia		Contour Valance/ No Valance		3" Fascia		4" Fascia	
	Width (inches)	Height (inches)	Width (inches)	Height (inches)	Width (inches)	Height (inches)	Width (inches)	Height (inches)	Width (inches)	Height (inches)	Width (inches)	Height (inches)
Momentum(Soft, Seashell); Parisian Cream; Luxe Leather; Etched Brown; Brushed Pewter; Toasted Spice)	94	144	94	67	94	144	NO RR	NO RR	NO RR	NO RR	NO RR	NO RR
Monticello(Mist; Burro; Dune; Tikki; Rust)	96	144	96	48	96	144	114	83	144	124	48	114
Nantucket(Vintage Veil; Taupe Utopia; Rich Sable; Spice)	96	144	96	43	96	144	NO RR	NO RR	NO RR	NO RR	NO RR	NO RR
Northshore(Char; Cream Coverlet; Safari; Fine Flint; Icy Waterfall; Lakeside)	115	144	115	80	115	144	NO RR	NO RR	NO RR	NO RR	NO RR	NO RR
Pannier(Black Dahlia; Creamy Mocha; Feather White; Riverbed Brown)	96	144	96	46	96	144	NO RR	NO RR	NO RR	NO RR	NO RR	NO RR
Paving Stone BO(Bechamel; Pale Adobe; Eventide; Almond Butter)	115	144	113	98	115	144	112	102	144	113	98	112
PlanetSafe(French Pastry; Gray Perfection; Cool Cave)	103	144	103	144	103	144	NO RR	NO RR	NO RR	NO RR	NO RR	NO RR
Plexus 1%(Renewal; Provisions; Chalcedony; Stately; Landmark; Travertine; Penumbra; Nutley Pier; Black Granite; Niche)	116	144	116	51	97	134	139	100	139	117	51	139
Plexus 3%(Renewal; Provisions; Chalcedony; Stately; Landmark; Travertine; Penumbra; Nutley Pier; Black Granite; Niche)	116	144	116	52	98	135	140	100	140	118	52	140
Plexus 5%(Renewal; Provisions; Chalcedony; Stately; Landmark; Travertine; Penumbra; Nutley Pier; Black Granite; Niche)	116	144	116	57	116	123	141	100	141	117	57	141
Porter(Fuji Fog; Misty Marsh; Executive Gray; Rain; Classy Carbon)	96	139	96	44	96	136	NO RR	NO RR	NO RR	NO RR	NO RR	NO RR
Providence-BO(Vanilla Bean ; Woolen Mittens; Varsity Blue; Stacked Stone ; Golden Leaf; Dewdrop)	109	144	94	59	112	124	NO RR	NO RR	NO RR	NO RR	NO RR	NO RR
Providence-L(Vanilla Bean ; Woolen Mittens; Varsity Blue; Stacked Stone ; Golden Leaf; Dewdrop)	115	144	99	81	115	144	NO RR	NO RR	NO RR	NO RR	NO RR	NO RR
Quintessence(White Enchantment; Flecked Gray; Gilded Linen; Gray Alloy; Black Facet)	116	144	110	68	116	144	NO RR	NO RR	NO RR	NO RR	NO RR	NO RR
Regent(First Frost; Smoky Taupe; Fossil; Lulling Storm; Magnetic)	115	144	115	104	115	144	NO RR	NO RR	NO RR	NO RR	NO RR	NO RR
Renaissance(Blushed Paradise; Subdued Botanical)	92	144	92	139	92	144	NO RR	NO RR	NO RR	NO RR	NO RR	NO RR
Riverbend(Rust; Steel; Natural; Khaki; Maduro)	72	144	72	54	72	144	NO RR	NO RR	NO RR	NO RR	NO RR	NO RR
Sabine(Smooth Java; Lush Garden; Midnight Blue; Summer Gray; Powdery Sand)	96	144	96	80	96	144	NO RR	NO RR	NO RR	NO RR	NO RR	NO RR

NOTES: Due to continuous manufacturing improvements, minimums and maximums are subject to change. Please call customer service for up to date size considerations.

Features and Size Considerations

120-Volt RTS
 Minimum Width: 24.5"
 Minimum Height: 13"

120-Volt Standard
 Minimum Width: 23"
 Minimum Height: 13"

Roller and Solar Shades: 120-Volt Motor Maximum Shade Size (120V RTS ST40 Motor or 120V STD ST40 Motor)

Valance Type	Normal Fabric Orientation												Fabric Turned Width for Height (railroaded)					
	Contour Valance/ No Valance			3" Fascia			4" Fascia			Contour Valance/ No Valance			3" Fascia			4" Fascia		
	Width (inches)	Height (inches)		Width (inches)	Height (inches)		Width (inches)	Height (inches)		Width (inches)	Height (inches)		Width (inches)	Height (inches)		Width (inches)	Height (inches)	
SafeSync(Wheat Harvest; Woodland Taupe; Bronze Haze; Black Sands; Elusive Ebony)	96	144		96	56		96	121		NO RR	NO RR		NO RR	NO RR		NO RR	NO RR	
Sahara Ridge(Vapor ; Alabaster; Birch Grove)	106	144		106	59		106	144		NO RR	NO RR		NO RR	NO RR		NO RR	NO RR	
Sakura(White Lattice; Zen Gray; Craftsman)	97	124		97	38		94	120		NO RR	NO RR		NO RR	NO RR		NO RR	NO RR	
Sanguine(Blue Pueblo; White Serenity; Misty Morning; Gray Estate; Montauk Slate)	78	144		78	42		78	142		NO RR	NO RR		NO RR	NO RR		NO RR	NO RR	
Santorini(Desert Sands; Unexpected Amber; Evocative Ivory)	76	144		76	110		76	144		NO RR	NO RR		NO RR	NO RR		NO RR	NO RR	
Shadow(White; Beige; Tan; Light Gray; Dark Gray)	119	144		116	85		119	144		NO RR	NO RR		NO RR	NO RR		NO RR	NO RR	
Sheffield(Chelsea; Henley; Windsor; Tuscon; Eolipse; Weathered; Meadow; Manor)	108	144		108	91		108	144		NO RR	NO RR		NO RR	NO RR		NO RR	NO RR	
Shiloh(Water Lily; Sunlit Stone; Almond; Distant Thunder; Gentle Gray)	115	144		115	111		115	144		NO RR	NO RR		NO RR	NO RR		NO RR	NO RR	
Solana BO(Drift ; Blue Breeze; Dandelion Wish; Brown Tint; Black Whirlwind; Sweet Dreams)	114	144		109	61		114	130		NO RR	NO RR		NO RR	NO RR		NO RR	NO RR	
Spring Bloom(Kissed Olive; Cultivated Kalamata; Tropical Garden; Sunmeadow; Botanical Garden; Cherry Blossom)	92	144		92	132		92	144		131	79		144	76		131	79	
Standard Weave 1%(Calcite; Polished)	124	144		116	78		124	144		144	108		144	108		144	108	
Standard Weave 1%(Veranda; Caf� Doppio; Chiseled)	124	144		114	83		124	144		144	108		144	108		144	108	
Standard Weave 10%(Calcite; Polished)	116	144		116	93		116	144		115	103		144	100		117	93	
Standard Weave 10%(Veranda; Caf� Doppio; Chiseled)	116	144		116	89		116	144		113	103		144	100		116	89	
Standard Weave 3%(Calcite; Polished)	124	144		116	84		124	144		144	108		144	108		116	84	
Standard Weave 3%(Veranda; Caf� Doppio; Chiseled)	124	144		114	84		124	144		144	108		144	108		114	84	
Standard Weave 5%(Calcite; Polished)	124	144		117	84		124	144		144	108		144	108		117	84	
Standard Weave 5%(Veranda; Caf� Doppio; Chiseled)	124	144		115	88		124	144		144	108		144	108		115	88	
Steel House(Cavern Floor; Cloud ; Buff; Chocolate Souffle)	96	144		96	70		96	144		NO RR	NO RR		NO RR	NO RR		NO RR	NO RR	
Suburban II(White ; Mystic ; Highland)	72	144		72	131		72	144		133	59		144	55		133	59	
Tableaux(White Tranquility; Slaty Gray ; Gray Opulence; Craftsman Brown; Provincial Plum; Ivory Cameo)	96	144		96	36		96	125		NO RR	NO RR		NO RR	NO RR		NO RR	NO RR	

NOTES: Due to continuous manufacturing improvements, minimums and maximums are subject to change. Please call customer service for up to date size considerations.

Features and Size Considerations

120-Volt RTS
 Minimum Width: 24.5"
 Minimum Height: 13"

120-Volt Standard
 Minimum Width: 23"
 Minimum Height: 13"

Roller and Solar Shades: 120-Volt Motor Maximum Shade Size (120V RTS ST40 Motor or 120V STD ST40 Motor)

Valance Type	Normal Fabric Orientation						Fabric Turned Width for Height (railroaded)					
	Contour Valance/ No Valance		3" Fascia		4" Fascia		Contour Valance/ No Valance		3" Fascia		4" Fascia	
	Width (inches)	Height (inches)	Width (inches)	Height (inches)	Width (inches)	Height (inches)	Width (inches)	Height (inches)	Width (inches)	Height (inches)	Width (inches)	Height (inches)
Tattered Husk BO(Pale Adobe; Feather White; Crystal; Polished Ore; Woven Canvas)	109	144	109	59	109	135	NO RR	NO RR	NO RR	NO RR	NO RR	NO RR
Tattered Husk LFPale Adobe; Feather White; Crystal; Polished Ore; Woven Canvas)	108	144	108	66	108	144	NO RR	NO RR	NO RR	NO RR	NO RR	NO RR
Terrain(Gray Frost; Pale Adobe ; Pale Rhino)	106	144	106	81	106	144	NO RR	NO RR	NO RR	NO RR	NO RR	NO RR
Thesis(Weathered Stone; Bluebook White; Summer Krakas; Oxford Blue; Macho Macchiato; Dusky Titanium)	70	144	70	66	70	144	NO RR	NO RR	NO RR	NO RR	NO RR	NO RR
Tuvalu(Wisteria White; Silver Tree; Dusky Botanical)	106	144	106	111	106	144	NO RR	NO RR	NO RR	NO RR	NO RR	NO RR
Unison(Igloo; Malted Milk; Mascarpone; Platinium; Khaki Sand; Rivermist)	115	144	115	118	115	144	NO RR	NO RR	NO RR	NO RR	NO RR	NO RR
Vancouver(Meringue; Heavenly; Light Fog; Good Graycloud; Capri; Master Mariner)	114	144	114	111	114	144	NO RR	NO RR	NO RR	NO RR	NO RR	NO RR
Vanguard 1%(Authentic; Gentle Beige; Chrome; Pendulum)	124	144	116	78	124	144	144	108	116	144	78	108
Vanguard 1%(Elusive; Macedonia; Dew; Homage; Peloton)	124	144	114	83	124	144	144	108	114	144	83	108
Vanguard 3%(Authentic; Gentle Beige; Chrome; Pendulum)	124	144	116	84	124	144	144	108	116	144	84	108
Vanguard 3%(Elusive; Macedonia; Dew; Homage; Peloton)	124	144	114	84	124	144	144	108	114	144	84	108
Vanguard 5%(Authentic; Gentle Beige; Chrome; Pendulum)	124	144	117	84	124	144	144	108	117	144	84	108
Vanguard 5%(Elusive; Macedonia; Dew; Homage; Peloton)	124	144	115	88	124	144	144	108	115	144	88	108
Wayfarer(Suetry White; Maldives Gray)	92	144	92	144	92	144	NO RR	NO RR	NO RR	NO RR	NO RR	NO RR
Whitcomb(Paloverde; Invitation; Juniper)	108	144	108	105	108	144	NO RR	NO RR	NO RR	NO RR	NO RR	NO RR
Whitehall(Veranda; Wolverine; Nectar; Westminster; Seattle Mist)	117	144	117	94	117	144	118	105	144	118	94	105
Whittaker BO(Sugar Quartz; Inspired Ivory; Orion; Gray Frost; Stone; Night Life)	113	144	113	61	113	130	NO RR	NO RR	NO RR	NO RR	NO RR	NO RR

NOTES: Due to continuous manufacturing improvements, minimums and maximums are subject to change. Please call customer service for up to date size considerations.

Features and Size Considerations

This table provides the maximum shade size available by fabric, control type, and valance style. Only the large cassette valance is available for the dual shade. Fabric turned width for height (railroaded) may curl along its edge. This is not a defect in the product. Small and medium cassette valances are not available.

Roller and Solar Shades: Dual Shades Maximum Shade Size

Valance Type	Normal Fabric Orientation										Fabric Turned Width for Height (railroaded)									
	12V Sonesse 28 RTS WF Ext Batt No Cassette/ No Valance		12V Sonesse 28 RTS WF Ext Batt Large Cassette		24-Volt Motor No Cassette/ No Valance		24-Volt Motor Large Cassette		12V Sonesse 28 RTS WF Ext Batt No Cassette/ No Valance at Maximum Width		12V Sonesse 28 RTS WF Ext Batt Large Cassette at Maximum Length		24-Volt Motor No Cassette/ No Valance		24-Volt Motor Large Cassette					
	Width (inches)	Height (inches)	Width (inches)	Height (inches)	Width (inches)	Height (inches)	Width (inches)	Height (inches)	Width (inches)	Height (inches)	Width (inches)	Height (inches)	Width (inches)	Height (inches)	Width (inches)	Height (inches)				
Aberdeen BO(Ingenue Pearl; Etrivescene; Pristine; Dulcet Graphite)	67	108	68	97	67	108	68	97	NO RR	NO RR	NO RR	NO RR	NO RR	NO RR	NO RR	NO RR				
Aberdeen LF(Ingenue Pearl; Etrivescene; Pristine; Dulcet Graphite)	92	123	92	109	92	123	92	109	98	82	83	84	98	82	98	82				
Arboretum BO(Serene; Monarch; Sirius; Distinguished)	72	108	73	101	87	93	89	82	89	82	75	84	89	82	89	82				
Arboretum LF(Serene; Monarch; Sirius; Distinguished)	90	136	91	121	90	136	91	121	96	82	82	84	96	82	96	82				
Bradley(Antique Silver; Hearstone; Midas; Azurine; Majesty; Everest)	71	83	72	75	88	66	90	58	NO RR	NO RR	NO RR	NO RR	NO RR	NO RR	NO RR	NO RR				
Bravado BO(Magnolia; Elusive Ecru; Tumbled Stone; Canterbury Night)	74	90	75	82	90	73	92	64	NO RR	NO RR	NO RR	NO RR	NO RR	NO RR	NO RR	NO RR				
Bravado LF(Magnolia; Elusive Ecru; Tumbled Stone; Canterbury Night)	79	110	81	98	96	89	97	79	NO RR	NO RR	NO RR	NO RR	NO RR	NO RR	NO RR	NO RR				
Broadcast(Constellation; Sonnet; Cashmere; Alfresco; Motif; Talliesin; Austere; Continental; Simplicity; Genuine; Gourmet; Serenade)	70	77	71	70	87	62	88	55	87	62	71	70	88	55	87	62				
Cambridge LF(White; Off White; Inkwell; Clay; Hawaiian Blue; Academy; Mirrage; Vernal Pond; Ivory)	94	121	94	121	94	121	94	121	95	110	95	110	95	110	95	110				
Cambridge RD(Hawaiian Blue; Academy; Mirrage; Vernal Pond; White; Off White; Inkwell ; Clay ; Ivory; Mist)	86	109	87	97	86	109	87	97	86	108	87	97	86	108	87	97				
Canyon Ridge BO(Arborio Rice; Fading Nimbus; Bona Fide Taupe; Shadow Mist; Evening Storm)	65	126	67	108	65	126	67	108	NO RR	NO RR	NO RR	NO RR	NO RR	NO RR	NO RR	NO RR				
Canyon Ridge LF(Arborio Rice; Fading Nimbus; Bona Fide Taupe; Shadow Mist; Evening Storm)	82	141	83	127	82	141	83	127	87	82	74	84	87	82	87	82				
Chronicles(Feather; Skyline; Sumatra; Tuxedo)	85	89	71	98	85	89	87	79	NO RR	NO RR	NO RR	NO RR	NO RR	NO RR	NO RR	NO RR				
Cloud Frost(Fading Nimbus; Shell; Creamy Mocha)	80	120	80	119	80	120	80	119	NO RR	NO RR	NO RR	NO RR	NO RR	NO RR	NO RR	NO RR				
Cloud Frost(Sea Stone)	82	99	83	88	82	99	83	88	NO RR	NO RR	NO RR	NO RR	NO RR	NO RR	NO RR	NO RR				

NOTES: Due to continuous manufacturing improvements, minimums and maximums are subject to change. Please call customer service for up to date size considerations. Seams may be added to fabrics to accommodate long shade requirements. Seams will be placed as close to the tube as possible; seam location is not selectable. Seams are visible when the shade is fully extended.

Features and Size Considerations

This table provides the maximum shade size available by fabric, control type, and valance style. Only the large cassette valance is available for the dual shade. Fabric turned width for height (railroaded) may curl along its edge. This is not a defect in the product. Small and medium cassette valances are not available.

Roller and Solar Shades: Dual Shades Maximum Shade Size

Valance Type	Normal Fabric Orientation						Fabric Turned Width for Height (railroaded)									
	12V Sonesse 28 RTS WF Ext Batt No Cassette/ No Valance		12V Sonesse 28 RTS WF Ext Batt Large Cassette		24-Volt Motor No Cassette/ No Valance		12V Sonesse 28 RTS WF Ext Batt No Cassette/ No Valance		12V Sonesse 28 RTS WF Ext Batt Large Cassette at Maximum Length		12V Sonesse 28 RTS WF Ext Batt Large Cassette at Maximum Width		24-Volt Motor No Cassette/ No Valance		24-Volt Motor Large Cassette	
	Width (inches)	Height (inches)	Width (inches)	Height (inches)	Width (inches)	Height (inches)	Width (inches)	Height (inches)	Width (inches)	Height (inches)	Width (inches)	Height (inches)	Width (inches)	Height (inches)	Width (inches)	Height (inches)
Complex(Couture; Chance; Oceans; Visage)	71	84	72	76	87	68	89	59	NO RR	NO RR	NO RR	NO RR	NO RR	NO RR	NO RR	NO RR
Conservancy -L(Edelweiss; Feather Grass; Golden Morel; Flowering Ash; Silver Maple; Black Peony; Sea Salt)	74	88	63	97	74	88	76	77	NO RR	NO RR	NO RR	NO RR	NO RR	NO RR	NO RR	NO RR
Conservancy-BO(Edelweiss; Feather Grass; Golden Morel; Flowering Ash; Silver Maple; Black Peony; Sea Salt)	56	84	58	74	69	68	70	60	NO RR	NO RR	NO RR	NO RR	NO RR	NO RR	NO RR	NO RR
Consummate Silk(Opalescence; Posh Platinum ; Bright Champagne; Pale Gold; Sandstone; Seafoam)	71	112	72	102	79	92	79	81	NO RR	NO RR	NO RR	NO RR	NO RR	NO RR	NO RR	NO RR
Debonair(Weekender Twill; Harberdasher Gray)	76	125	77	113	93	101	94	90	NO RR	NO RR	NO RR	NO RR	NO RR	NO RR	NO RR	NO RR
Delphine BO(Mythical Gray; Evocative White; Island Paradise; Dark Earth)	72	98	74	88	89	79	91	70	NO RR	NO RR	NO RR	NO RR	NO RR	NO RR	NO RR	NO RR
Delphine LF(Mythical Gray; Evocative White; Island Paradise; Dark Earth)	95	110	79	126	95	110	96	101	NO RR	NO RR	NO RR	NO RR	NO RR	NO RR	NO RR	NO RR
Destin BO(Natural Sherpa; Glacial Gray; Silver Lining; Deep Graphite; Morning Frost; White Whimsy)	71	99	72	89	87	80	89	71	NO RR	NO RR	NO RR	NO RR	NO RR	NO RR	NO RR	NO RR
Earth Synergy(Soft Down; Wild Oats; Taupe Secret; Quarry Gray; Caviar)	86	102	72	108	86	102	88	90	NO RR	NO RR	NO RR	NO RR	NO RR	NO RR	NO RR	NO RR
EcoEncore(Wint Condition; Lunar Light; Cocoa Powder)	95	119	95	119	95	119	95	119	NO RR	NO RR	NO RR	NO RR	NO RR	NO RR	NO RR	NO RR
Ellington 1%(Tonal Taupe; Dusky Moment; Vintage Records; Georgia Brown; Misty Slate)	62	98	63	88	76	79	78	70	62	98	78	70	78	79	76	70
Ellington 3%(Tonal Taupe; Dusky Moment; Vintage Records; Georgia Brown; Misty Slate)	78	83	65	93	78	83	80	73	78	83	78	73	80	78	83	73
Ellington 5%(Tonal Taupe; Dusky Moment; Vintage Records; Georgia Brown; Misty Slate)	79	84	65	94	79	84	80	74	NO RR	NO RR	NO RR	NO RR	NO RR	NO RR	NO RR	NO RR
Emerson(Freezing Point; Khaki Stripe; Poised Pewter)	74	82	75	74	91	66	93	58	NO RR	NO RR	NO RR	NO RR	NO RR	NO RR	NO RR	NO RR
Empirical(White Shimmer; Complex Carbon; Modern Gray; Classic Khaki)	93	123	93	123	93	123	93	123	NO RR	NO RR	NO RR	NO RR	NO RR	NO RR	NO RR	NO RR

NOTES: Due to continuous manufacturing improvements, minimums and maximums are subject to change. Please call customer service for up to date size considerations.

Seams may be added to fabrics to accommodate long shade requirements. Seams will be placed as close to the tube as possible; seam location is not selectable. Seams are visible when the shade is fully extended.

Features and Size Considerations

This table provides the maximum shade size available by fabric, control type, and valance style. Only the large cassette valance is available for the dual shade. Fabric turned width for height (railroaded) may curl along its edge. This is not a defect in the product. Small and medium cassette valances are not available.

Roller and Solar Shades: Dual Shades Maximum Shade Size

Valance Type	Normal Fabric Orientation						Fabric Turned Width for Height (railroaded)											
	12V Sonesse 28 RTS WF Ext Batt No Cassette/ No Valance		12V Sonesse 28 RTS WF Ext Batt Large Cassette		24-Volt Motor No Cassette/ No Valance		12V Sonesse 28 RTS WF Ext Batt No Cassette/ No Valance		12V Sonesse 28 RTS WF Ext Batt Large Cassette at Maximum Length		12V Sonesse 28 RTS WF Ext Batt No Cassette/ No Valance at Maximum Width		12V Sonesse 28 RTS WF Ext Batt Large Cassette at Maximum Width		24-Volt Motor No Cassette/ No Valance		24-Volt Motor Large Cassette	
	Width (inches)	Height (inches)	Width (inches)	Height (inches)	Width (inches)	Height (inches)	Width (inches)	Height (inches)	Width (inches)	Height (inches)	Width (inches)	Height (inches)	Width (inches)	Height (inches)	Width (inches)	Height (inches)	Width (inches)	Height (inches)
Emporium(Bookplate White)	89	115	75	119	89	115	90	102	77	62	91	60	NO RR	NO RR	NO RR	NO RR	NO RR	NO RR
Emporium(Silver Dollar ; Vintage Letterpress ; Sheet Music; Stepping Stone)	74	115	75	105	90	94	92	83	NO RR	NO RR	NO RR	NO RR	NO RR	NO RR	NO RR	NO RR	NO RR	NO RR
Emporium(Sepia Snapshot)	73	111	74	104	89	94	90	83	NO RR	NO RR	NO RR	NO RR	NO RR	NO RR	NO RR	NO RR	NO RR	NO RR
EnviroINFUSION(Calle Lilly; Modern Silver; Gray Fedora; Shoreline Sand; Colum Gray; Brownstone)	94	122	94	122	94	122	94	122	NO RR	NO RR	NO RR	NO RR	NO RR	NO RR	NO RR	NO RR	NO RR	NO RR
Essential(Classic White; Creamy Beige; Taupe; Smokey; Black; Black on Black; Forest Green; Canyon; Beige; Stone; Black)	70	144	70	144	70	144	70	144	77	62	91	60	91	60	91	60	91	60
Exposition(Consummate; Genesis; Wishlist; Resonance)	76	65	77	59	92	52	94	45	NO RR	NO RR	NO RR	NO RR	NO RR	NO RR	NO RR	NO RR	NO RR	NO RR
Flock BO(Skyscraper; Stallion; Evening Moonstone; Soft Beige; Brushwood)	79	49	80	44	96	38	98	33	NO RR	NO RR	NO RR	NO RR	NO RR	NO RR	NO RR	NO RR	NO RR	NO RR
Flock LFSkyscraper; Stallion; Evening Moonstone; Soft Beige; Brushwood)	87	41	88	37	103	32	105	27	NO RR	NO RR	NO RR	NO RR	NO RR	NO RR	NO RR	NO RR	NO RR	NO RR
Gleam(Gold Rush; Ebony Glimmer; Silver Shine; Glistening Waterfall)	78	102	80	90	78	102	80	90	NO RR	NO RR	NO RR	NO RR	NO RR	NO RR	NO RR	NO RR	NO RR	NO RR
Guildhall(Tenor; Illusion; Montage; Armor; Mystery)	70	88	70	85	85	76	87	67	NO RR	NO RR	NO RR	NO RR	NO RR	NO RR	NO RR	NO RR	NO RR	NO RR
Harmonics(Titanium; Frosty White; Fossil Gray; Grounded Greige; Mannered Gold; Deep Sapphire; Modern Moss)	90	107	75	119	90	107	91	95	NO RR	NO RR	NO RR	NO RR	NO RR	NO RR	NO RR	NO RR	NO RR	NO RR
Harmony(Pebble ; Tassel; Marina; Shiplap; Cityscape ; Harvest; Lavender)	92	124	93	112	92	124	93	112	NO RR	NO RR	NO RR	NO RR	NO RR	NO RR	NO RR	NO RR	NO RR	NO RR
Inkblot(Coastal Gray; Crystal; Haven; Navy Mosaic)	91	133	92	121	91	133	92	121	NO RR	NO RR	NO RR	NO RR	NO RR	NO RR	NO RR	NO RR	NO RR	NO RR
Jacinta(Candle Glow; Lavish Taupe; London Pewter; Greige Fusion; Charcoal)	94	125	95	116	94	125	95	116	NO RR	NO RR	NO RR	NO RR	NO RR	NO RR	NO RR	NO RR	NO RR	NO RR
Kindred(Endless Summer; Gilded Gray; Quarry; Ganache; City Skyline)	95	119	96	106	95	119	96	106	NO RR	NO RR	NO RR	NO RR	NO RR	NO RR	NO RR	NO RR	NO RR	NO RR
LiveWell(Dew Kissed; Finely Frosted; Succulent; Sandbar; Icelandic; Seaspray)	70	89	71	82	86	73	88	65	70	87	86	73	82	88	65	86	73	88

NOTES: Due to continuous manufacturing improvements, minimums and maximums are subject to change. Please call customer service for up to date size considerations. Seams may be added to fabrics to accommodate long shade requirements. Seams will be placed as close to the tube as possible; seam location is not selectable. Seams are visible when the shade is fully extended.

Features and Size Considerations

This table provides the maximum shade size available by fabric, control type, and valance style. Only the large cassette valance is available for the dual shade. Fabric turned width for height (railroaded) may curl along its edge. This is not a defect in the product. Small and medium cassette valances are not available.

Roller and Solar Shades: Dual Shades Maximum Shade Size

Valance Type	Normal Fabric Orientation						Fabric Turned Width for Height (railroaded)									
	12V Sonesse 28 RTS WF Ext Batt No Cassette/ No Valance		12V Sonesse 28 RTS WF Ext Batt Large Cassette		24-Volt Motor No Cassette/ No Valance		12V Sonesse 28 RTS WF Ext Batt No Cassette/ No Valance		12V Sonesse 28 RTS WF Ext Batt Large Cassette at Maximum Length		12V Sonesse 28 RTS WF Ext Batt Large Cassette at Maximum Width		24-Volt Motor No Cassette/ No Valance		24-Volt Motor Large Cassette	
	Width (inches)	Height (inches)	Width (inches)	Height (inches)	Width (inches)	Height (inches)	Width (inches)	Height (inches)	Width (inches)	Height (inches)	Width (inches)	Height (inches)	Width (inches)	Height (inches)	Width (inches)	Height (inches)
Manifest BO(Freshwater Pearl; Flint Rock; Savvy Gray; Lifting Fog; Ciabatta; Cream Filled)	84	131	85	119	84	131	85	119	NO RR	NO RR	NO RR	NO RR	NO RR	NO RR	NO RR	NO RR
Manifest LF(Freshwater Pearl; Flint Rock; Savvy Gray; Lifting Fog; Ciabatta; Cream Filled)	92	144	92	144	92	144	92	144	NO RR	NO RR	NO RR	NO RR	NO RR	NO RR	NO RR	NO RR
Mayfair(Giza Cotton; Ticked Ivory; Risotto; Silversmith; Varsity Fog; Open Seas; Mystic Meadow)	97	140	98	128	97	140	98	128	NO RR	NO RR	NO RR	NO RR	NO RR	NO RR	NO RR	NO RR
Merit(Clarity; Panoramic; Emulation; Atmosphere; Exquisite; Cavalier)	77	89	64	97	77	89	78	79	NO RR	NO RR	NO RR	NO RR	NO RR	NO RR	NO RR	NO RR
Momentum(Soft Seashell; Parisian Cream; Luxe Leather; Etched Brown; Brushed Pewter; Toasted Spice)	71	92	72	83	88	74	89	66	NO RR	NO RR	NO RR	NO RR	NO RR	NO RR	NO RR	NO RR
Monticello(Mist; Burro; Dune; Tikki; Rust)	74	68	75	62	91	54	92	48	74	68	74	68	74	68	74	68
Nantucket(Vintage Veil; Taupe Utopia; Rich Sable; Spice)	77	62	78	56	94	49	96	43	NO RR	NO RR	NO RR	NO RR	NO RR	NO RR	NO RR	NO RR
Northshore(Chai; Cream Coverlet; Safari; Fine Flint; Icy Waterfall; Lakeside)	76	108	78	98	93	88	95	77	NO RR	NO RR	NO RR	NO RR	NO RR	NO RR	NO RR	NO RR
Pannier(Black Dahlia; Creamy Mocha; Feather White; Riverbed Brown)	75	65	76	59	92	52	94	45	NO RR	NO RR	NO RR	NO RR	NO RR	NO RR	NO RR	NO RR
Paving Stone BO(Bechamel; Pale Adobe; Eventide; Almond Butter)	82	106	83	95	82	106	83	95	82	105	82	105	82	105	82	105
PlanetSafe(French Pastry; Gray Perfection; Cool Cave)	94	122	94	122	94	122	94	122	NO RR	NO RR	NO RR	NO RR	NO RR	NO RR	NO RR	NO RR
Plexus 1%(Renewal; Provisions; Chalcedony; Stately; Landmark; Travertine; Penumbra; Nutley Pier; Black Granite; Niche)	68	72	70	65	85	57	87	50	68	72	85	57	65	87	50	87
Plexus 3%(Renewal; Provisions; Chalcedony; Stately; Landmark; Travertine; Penumbra; Nutley Pier; Black Granite; Niche)	69	73	70	66	85	58	87	51	69	73	85	58	66	87	51	87
Plexus 5%(Renewal; Provisions; Chalcedony; Stately; Landmark; Travertine; Penumbra; Nutley Pier; Black Granite; Niche)	68	80	69	72	84	64	86	56	68	80	84	64	72	86	56	86

NOTES: Due to continuous manufacturing improvements, minimums and maximums are subject to change. Please call customer service for up to date size considerations. Seams may be added to fabrics to accommodate long shade requirements. Seams will be placed as close to the tube as possible; seam location is not selectable. Seams are visible when the shade is fully extended.

Features and Size Considerations

This table provides the maximum shade size available by fabric, control type, and valance style. Only the large cassette valance is available for the dual shade. Fabric turned width for height (railroaded) may curl along its edge. This is not a defect in the product. Small and medium cassette valances are not available.

Roller and Solar Shades: Dual Shades Maximum Shade Size

Valance Type	Normal Fabric Orientation						Fabric Turned Width for Height (railroaded)									
	12V Sonesse 28 RTS WF Ext Batt No Cassette/ No Valance		12V Sonesse 28 RTS WF Ext Batt Large Cassette		24-Volt Motor No Cassette/ No Valance		12V Sonesse 28 RTS WF Ext Batt No Cassette/ No Valance at Maximum Width		12V Sonesse 28 RTS WF Ext Batt Large Cassette at Maximum Length		12V Sonesse 28 RTS WF Ext Batt Large Cassette at Maximum Width		24-Volt Motor No Cassette/ No Valance		24-Volt Motor Large Cassette	
	Width (inches)	Height (inches)	Width (inches)	Height (inches)	Width (inches)	Height (inches)	Width (inches)	Height (inches)	Width (inches)	Height (inches)	Width (inches)	Height (inches)	Width (inches)	Height (inches)	Width (inches)	Height (inches)
Porter(Fuji Fog; Misty Marsh; Executive Gray; Rain; Classy Carbon)	69	62	70	56	84	50	86	43	NO RR	NO RR	NO RR	NO RR	NO RR	NO RR	NO RR	NO RR
Providence-BO(Vanilla Bean ; Woolen Mittens; Varsity Blue; Stacked Stone ; Golden Leaf; Dewdrop)	56	81	57	73	69	65	71	57	NO RR	NO RR	NO RR	NO RR	NO RR	NO RR	NO RR	NO RR
Providence-LF(Vanilla Bean ; Woolen Mittens; Varsity Blue; Stacked Stone ; Golden Leaf; Dewdrop)	74	89	62	99	74	89	75	79	NO RR	NO RR	NO RR	NO RR	NO RR	NO RR	NO RR	NO RR
Quintessence(White Enchantment; Flecked Gray; Gilded Linen; Gray Alloy; Black Facet)	66	93	67	84	81	75	83	66	NO RR	NO RR	NO RR	NO RR	NO RR	NO RR	NO RR	NO RR
Regent(First Frost; Smoky Taupe; Fossil; Lulling Storm; Magnetic)	96	114	81	124	96	114	97	101	NO RR	NO RR	NO RR	NO RR	NO RR	NO RR	NO RR	NO RR
Renaissance(Blushed Paradise; Subdued Botanical)	92	140	92	133	92	140	92	133	NO RR	NO RR	NO RR	NO RR	NO RR	NO RR	NO RR	NO RR
Riverbend(Rust; Steel; Natural; Khaki; Maduro)	72	75	72	68	72	60	72	53	NO RR	NO RR	NO RR	NO RR	NO RR	NO RR	NO RR	NO RR
Sabine(Smooth Java; Lush Garden; Midnight Blue; Summer Gray; Powdery Sand)	84	88	70	98	84	88	86	78	NO RR	NO RR	NO RR	NO RR	NO RR	NO RR	NO RR	NO RR
SafeSync(Wheat Harvest; Woodland Taupe; Bronze Haze; Black Sands; Elusive Ebony)	63	78	64	71	78	63	80	55	NO RR	NO RR	NO RR	NO RR	NO RR	NO RR	NO RR	NO RR
Sahara Ridge(Vapor ; Alabaster; Birch Grove)	81	82	82	74	98	66	99	58	NO RR	NO RR	NO RR	NO RR	NO RR	NO RR	NO RR	NO RR
Sakura(White Lattice; Zen Gray; Craftsman)	67	56	69	50	83	44	85	38	NO RR	NO RR	NO RR	NO RR	NO RR	NO RR	NO RR	NO RR
Sanguine(Blue Pueblo; White Serenity; Misty Morning; Gray Estate; Montauk Slate)	74	61	75	54	78	48	78	42	NO RR	NO RR	NO RR	NO RR	NO RR	NO RR	NO RR	NO RR
Santorini(Desert Sands; Unexpected Umber; Evocative Ivory)	76	144	76	132	76	120	76	106	NO RR	NO RR	NO RR	NO RR	NO RR	NO RR	NO RR	NO RR
Shadow(White; Beige; Tan; Light Gray; Dark Gray)	84	93	71	97	84	93	86	82	NO RR	NO RR	NO RR	NO RR	NO RR	NO RR	NO RR	NO RR
Sheffield(Cheisea; Henley; Windsor; Tuscon; Eclipse; Weathered; Meadow; Manor)	78	122	80	109	95	100	96	88	NO RR	NO RR	NO RR	NO RR	NO RR	NO RR	NO RR	NO RR

NOTES: Due to continuous manufacturing improvements, minimums and maximums are subject to change. Please call customer service for up to date size considerations. Seams may be added to fabrics to accommodate long shade requirements. Seams will be placed as close to the tube as possible; seam location is not selectable. Seams are visible when the shade is fully extended. Not available with Sonesse rechargeable motor.

Features and Size Considerations

This table provides the maximum shade size available by fabric, control type, and valance style. Only the large cassette valance is available for the dual shade. Fabric turned width for height (railroaded) may curl along its edge. This is not a defect in the product. Small and medium cassette valances are not available.

Roller and Solar Shades: Dual Shades Maximum Shade Size

Valance Type	Normal Fabric Orientation						Fabric Turned Width for Height (railroaded)									
	12V Sonesse 28 RTS WF Ext Batt No Cassette/ No Valance		12V Sonesse 28 RTS WF Ext Batt Large Cassette		24-Volt Motor No Cassette/ No Valance		12V Sonesse 28 RTS WF Ext Batt No Cassette/ No Valance		12V Sonesse 28 RTS WF Ext Batt Large Cassette at Maximum Length		12V Sonesse 28 RTS WF Ext Batt Large Cassette at Maximum Width		24-Volt Motor No Cassette/ No Valance		24-Volt Motor Large Cassette	
	Width (inches)	Height (inches)	Width (inches)	Height (inches)	Width (inches)	Height (inches)	Width (inches)	Height (inches)	Width (inches)	Height (inches)	Width (inches)	Height (inches)	Width (inches)	Height (inches)	Width (inches)	Height (inches)
Shiloh(Water Lily; Sunlit Stone; Almond; Distant Thunder; Gentle Gray)	94	115	95	107	94	115	95	107	NO RR	NO RR	NO RR	NO RR	NO RR	NO RR	NO RR	NO RR
Solana BO(Drift; Blue Breeze; Dandelion Wish; Brown Tint; Black Whirlwind; Sweet Dreams)	64	84	66	76	79	68	81	60	NO RR	NO RR	NO RR	NO RR	NO RR	NO RR	NO RR	NO RR
Spring Bloom(Kissed Olive; Cultivated Kalamata; Tropical Garden; Summeradow; Botanical Garden; Cherry Blossom)	92	140	92	127	92	140	92	127	84	84	84	82	84	98	82	82
Standard Weave 1%(Calcite; Polished)	84	86	71	87	84	86	86	76	84	86	84	86	71	86	76	86
Standard Weave 1%(Veranda; Café Doppio; Chiseled)	82	91	68	101	82	91	84	80	82	91	82	84	68	84	80	84
Standard Weave 10%(Calcite; Polished)	85	102	71	110	85	102	87	90	85	102	85	102	71	87	90	102
Standard Weave 10%(Veranda; Café Doppio; Chiseled)	84	98	71	101	84	98	86	86	84	98	84	98	71	86	86	98
Standard Weave 3%(Calcite; Polished)	84	92	70	101	84	92	86	82	84	92	84	92	70	86	82	92
Standard Weave 3%(Veranda; Café Doppio; Chiseled)	83	92	71	87	83	92	85	82	83	92	83	92	71	85	82	92
Standard Weave 5%(Calcite; Polished)	85	92	71	101	85	92	87	82	85	92	85	92	71	87	82	92
Standard Weave 5%(Veranda; Café Doppio; Chiseled)	83	97	85	86	83	97	85	86	83	97	83	97	85	85	86	97
Steel House(Cavern Floor; Cloud; Buff; Chocolate Souffle)	72	96	74	87	89	78	91	68	NO RR	NO RR	NO RR	NO RR	NO RR	NO RR	NO RR	NO RR
Suburban II(White; Mystic; Highland)	72	144	72	144	72	141	72	125	100	62	100	62	100	100	62	100
Tableaux(White Tranquility; Stately Gray; Gray Opulence; Craftsman Brown; Provincial Plum; Ivory Cameo)	74	53	76	47	91	42	93	36	NO RR	NO RR	NO RR	NO RR	NO RR	NO RR	NO RR	NO RR
Tattered Husk BO(Pale Adobe; Feather White; Crystal; Polished Ore; Woven Canvas)	74	81	76	73	91	65	93	57	NO RR	NO RR	NO RR	NO RR	NO RR	NO RR	NO RR	NO RR
Tattered Husk LF(Pale Adobe; Feather White; Crystal; Polished Ore; Woven Canvas)	82	91	83	82	99	73	100	65	NO RR	NO RR	NO RR	NO RR	NO RR	NO RR	NO RR	NO RR

NOTES: Due to continuous manufacturing improvements, minimums and maximums are subject to change. Please call customer service for up to date size considerations. Seams may be added to fabrics to accommodate long shade requirements. Seams will be placed as close to the tube as possible; seam location is not selectable. Seams are visible when the shade is fully extended.

Features and Size Considerations

Exterior Solar Shades Motorized Lift

Order Entry: 120V Motor 3-Wire RTS



Refer to individual product information guide for specific option information for the product being ordered.

Features

- Operate exterior shades virtually anywhere around the home, up to 65 foot RTS range
- Provides easy operation of outdoor living space shades
- Manages harsh sun glare and solar heat, assists with temperature control
- Blocks damaging UV rays while maintaining outdoor view
- Motor located on the left or right side, standard on right
- Powered with 10 foot power cable; optional outdoor-rated plug
- Available with large cassette only, choose Brown (873), Vanilla (970), White (871), or Black (939)
- Available as standard roll only
- Stainless steel guide cables and unique universal cable locks (sill, jam, or wall mounted) are included

Control and Power Options

- Multiple control and power options available; see options section for availability

Size Considerations				
Motor Type	Order Entry	Minimum Width (inches)	Minimum Height (inches)	Light Gap Per Side (inches)
Exterior 120-Volt RTS	120V Motor 3-Wire RTS (6)	32	13	1 to 1 ⁵ / ₁₆

Exterior Solar Shades: Maximum Shade Size

Fabric	Normal Fabric Orientation		Fabric Turned Width for Height (railroaded)			
	Width (inches)	Height (inches)	120-Volt Motor Large Cassette		120-Volt Motor Large Cassette at Maximum Width	
			Width (inches)	Height (inches)	Width (inches)	Height (inches)
Aberdeen BO (Ingenu Pearl; Effervescence; Pristine; Dulcet Graphite)	92	144	NO RR	NO RR	NO RR	NO RR
Aberdeen LF (Ingenu Pearl; Effervescence; Pristine; Dulcet Graphite)	92	144	144	76	144	71
Broadcast (Constellation; Sonnet; Cashmere; Alfresco; Motif; Taliesin; Austere; Continental; Simplicity; Genuine; Gourmet; Serenade)	116	144	136	101	144	84
Canyon Ridge BO (Arborio Rice; Fading Nimbus; Bona Fide Taupe; Shadow Mist; Evening Storm)	92	144	NO RR	NO RR	NO RR	NO RR
Canyon Ridge LF (Arborio Rice; Fading Nimbus; Bona Fide Taupe; Shadow Mist; Evening Storm)	92	144	142	76	144	71
Chronicles (Feather; Skyline; Sumatra; Tuxedo)	96	144	NO RR	NO RR	NO RR	NO RR
Cloud Frost (Fading Nimbus; Shell; Creamy Mocha)	119	144	NO RR	NO RR	NO RR	NO RR
Cloud Frost (Sea Stone)	119	144	NO RR	NO RR	NO RR	NO RR
Exposition (Consummate; Genesis; Wishlist; Resonance)	96	144	NO RR	NO RR	NO RR	NO RR
Flock BO (Skyscraper; Stallion; Evening Moonstone; Soft Beige; Brushwood)	108	120	NO RR	NO RR	NO RR	NO RR
Flock LF (Skyscraper; Stallion; Evening Moonstone; Soft Beige; Brushwood)	108	102	NO RR	NO RR	NO RR	NO RR
Guildhall (Tenor; Illusion; Montage; Armor; Mystery)	96	144	NO RR	NO RR	NO RR	NO RR
Inkblot (Coastal Gray; Crystal; Haven; Navy Mosaic)	119	144	NO RR	NO RR	NO RR	NO RR

Due to continuous manufacturing improvements, minimums, and maximums are subject to change. Please call customer service for up to date size considerations.

NOTE: These tables provide the maximum shade size available by fabric and cassette.

Seams may be added to fabrics to accommodate long shade requirements. For shades longer than material width, seams will be visible when the shade is fully extended. Refer to exterior solar shades product information guide for pricing.

Features and Size Considerations

Exterior Solar Shades: Maximum Shade Size

	Normal Fabric Orientation		Fabric Turned Width for Height (railroaded)			
	120-Volt Motor Large Cassette		120-Volt Motor Large Cassette		120-Volt Motor Large Cassette at Maximum Width	
Fabric	Width (inches)	Height (inches)	Width (inches)	Height (inches)	Width (inches)	Height (inches)
Merit(Clarity; Panoramic; Emulation; Atmosphere; Exquisite; Cavalier)	96	144	NO RR	NO RR	NO RR	NO RR
Monticello(Mist; Burro; Dune; Tikki; Rust)	96	144	144	81	144	73
Pannier (Black Dahlia; Creamy Mocha; Feather White; Riverbed Brown)	96	144	NO RR	NO RR	NO RR	NO RR
Paving Stone BO (Bechamel; Pale Adobe; Eventide; Almond Butter)	115	144	141	100	144	95
Plexus 1% (Renewal; Provisions; Chalcedony; Stately; Landmark; Travertine; Penumbra; Nutley Pier; Black Granite; Niche)	116	144	131	101	144	77
Plexus 3% (Renewal; Provisions; Chalcedony; Stately; Landmark; Travertine; Penumbra; Nutley Pier; Black Granite; Niche)	116	144	133	101	144	78
Plexus 5%(Renewal; Provisions; Chalcedony; Stately; Landmark; Travertine; Penumbra; Nutley Pier; Black Granite; Niche)	116	144	134	101	144	86
Sahara Ridge (Vapor ; Alabaster; Birch Grove)	106	144	NO RR	NO RR	NO RR	NO RR
Spring Bloom (Kissed Olive; Cultivated Kalamata; Tropical Garden; Sunmeadow; Botanical Garden; Cherry Blossom)	92	144	144	76	144	71
Standard Weave 1% (Calcite; Polished)	124	144	138	109	144	104
Standard Weave 1% (Veranda; Café Doppio; Chiseled)	124	144	137	109	144	104
Standard Weave 10% (Calcite; Polished)	116	144	144	101	144	96
Standard Weave 10% (Veranda; Café Doppio; Chiseled)	116	144	143	101	144	96
Standard Weave 3% (Calcite; Polished)	124	144	140	109	144	104
Standard Weave 3% (Veranda; Café Doppio; Chiseled)	124	144	138	109	144	104
Standard Weave 5% (Calcite; Polished)	124	144	141	109	144	104
Standard Weave 5% (Veranda; Café Doppio; Chiseled)	124	144	140	109	144	104
Steel House (Cavern Floor; Cloud ; Buff; Chocolate Souffle)	96	144	NO RR	NO RR	NO RR	NO RR
Tattered Husk BO (Pale Adobe; Feather White; Crystal; Polished Ore; Woven Canvas)	109	144	NO RR	NO RR	NO RR	NO RR
Tattered Husk LF (Pale Adobe; Feather White; Crystal; Polished Ore; Woven Canvas)	108	144	NO RR	NO RR	NO RR	NO RR
Terrain (Gray Frost; Pale Adobe ; Pale Rhino)	106	144	NO RR	NO RR	NO RR	NO RR
Vanguard 1% (Authentic; Gentle Beige; Chrome; Pendulum)	124	144	138	109	144	104
Vanguard 1% (Elusive; Macedonia; Dew; Homage; Peloton)	124	144	137	109	144	104
Vanguard 3%(Authentic; Gentle Beige; Chrome; Pendulum)	124	144	140	109	144	104
Vanguard 3%(Elusive; Macedonia; Dew; Homage; Peloton)	124	144	138	109	144	104
Vanguard 5%(Authentic; Gentle Beige; Chrome; Pendulum)	124	144	141	109	144	104
Vanguard 5%(Elusive; Macedonia; Dew; Homage; Peloton)	124	144	140	109	144	104

Due to continuous manufacturing improvements, minimums, and maximums are subject to change. Please call customer service for up to date size considerations.

NOTE: These tables provide the maximum shade size available by fabric and cassette.

Seams may be added to fabrics to accommodate long shade requirements. For shades longer than material width, seams will be visible when the shade is fully extended. Refer to exterior solar shades product information guide for pricing.

Options

Guide Cables (motorized exterior shades only)

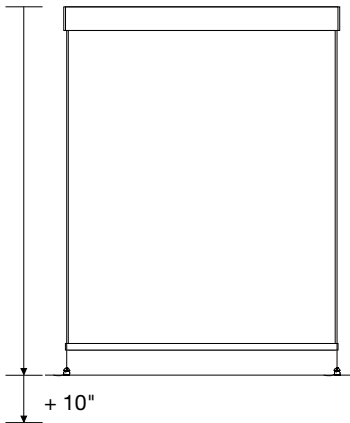

Use the following guidelines to determine the guide cable length that will be provided with your shade.

- Add 10" to the shade height to determine guide cable length
 - Cable lengths available are: 54", 80", 144", and 186"
 - The next longest cable length will be supplied with your measurement
 - All cables are stainless steel and include cable locks
 - Cables can be cut to length at time of installation

EXAMPLE: Shade height is 95". Adding 10" = 105".
Shade will come with a guide cable at 144".

Options

Motorized Graber® Blinds and Shades feature Somfy® Radio Frequency Motors and Accessories. All Somfy Radio Frequency Motors utilize Somfy's Proprietary Protocol Radio Technology Somfy® (RTS).

Exterior Solar Shade Motorization Controls

	<p>Telis Handheld Remotes (Exterior rated)</p> <ul style="list-style-type: none"> • Compatible with all Somfy RTS motors • Used to control single blinds/shades on each channel or group blinds/shades performing the same function • Battery included • Remote includes convenient mounting hardware for hanging when not in use • Controls unlimited number of motors • Water resistant and shock proof for outdoor use. <p>Telis 1, Single-Channel Remote Available colors: Patio Blue</p> <p>Telis 5, Five-Channel Remote Available colors: Patio Blue</p>
	<p>Eolis RTS Wind Sensor</p> <ul style="list-style-type: none"> • The Somfy's Eolis RTS wind sensor is a radio wind sensor for exterior motorized lift shades. • The sensor detects a wind threshold and automatically raises the shades. • The wind threshold is adjustable. • Powered by plugging into a 120-volt electrical outlet. • Exterior-rated fasteners are not included.
	<p>Exterior-Rated Plug</p> <ul style="list-style-type: none"> • Optional black electrical 3-wire plug, 15 amp, to be used with a GFCI outlet. This allows the shade to be plugged in versus hard-wired.

Options

12-Volt Power Considerations

12-volt motors can be powered by batteries, plug-in transformer, or multi-motor power supply. Below are some considerations when planning for power.

Power Considerations

Larger shades consume more power while operating. When choosing the appropriate power source based on shade size, we recommend the following power source for best performance.

Shade size (square inches)	Power Options
0 - 3,600	Batteries (single or dual), Rechargeable Li-ion Battery Pack, plug-in or multi-motor power supply
3,600 - 7,200	Dual battery tubes, Rechargeable Li-ion Battery Pack, plug-in or multi-motor power supply
7200	Rechargeable Li-ion Battery Pack, plug-in or multi-motor power pack



Outside Mount

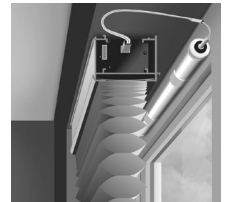

Inside Mount

Battery Tube Considerations

Battery power recommended for maximum of 10 shades for best performance.

- For outside mounts, battery tubes can be installed above or to the side of the shade
- For inside mounts, battery tubes are usually top-mounted (behind the headrail) between the shade and the window; to mount the battery tubes, additional recessed space will be needed

Low Voltage 12-Volt Power Components (non-rechargeable motors)

	<p>Battery Tubes</p> <ul style="list-style-type: none"> • Reloadable and are available with or without batteries • Each tube requires 8 AA lithium batteries • Each tube includes 2 battery clips • Optional 48" or 96" extensions available <p>Battery Tube Dimensions: 18" x 1 1/8" Dual Battery Tube Dimensions: 18" x 2 1/4" (installed side-by-side) 36" x 1 1/8" (installed end-to-end)</p> <p>Single Battery Tube with Flush Mount: product flush mount + 1 1/8" Single Battery Tube Minimum Recessed Space: product minimum recessed space + 1 1/8" Dual Battery Tube with Flush Mount: product flush mount + 2 1/4" Dual Battery Tube Minimum Recessed Space: product minimum recessed space + 2 1/4"</p> <p>NOTE: For best performance, use only AA lithium batteries.</p>
	<p>Rechargeable Li-ion Battery Pack</p> <ul style="list-style-type: none"> • External lithium-ion battery used to power the 12V Sonesse RTS WF Ext Batt • Discreet design allows for placement in smaller window coverings • Window covering can be operated while charging the battery • Charges with Li-ion Charger, which is sold separately • Dimensions: 9.8" L x 1" W x 0.9" D • Cable length: 6"

Rechargeable Power Considerations

Shades will need charging on-site before installation.

	<p>Li-ion Charger</p> <ul style="list-style-type: none"> • Sold separately • Conveniently charge the 12V RTS WF motors and Rechargeable Li-ion Battery Pack • 13 foot power cord, white only • LED indicator on Charger: <ul style="list-style-type: none"> • Solid Red - Charging • Solid Green - Charging Complete
--	--

Options

Low Voltage 12-Volt and 24-Volt Power Considerations



Plug-In Transformer

- Eliminates the need for batteries
- Available in White only
- 12-volt: 72" power cord and 96" extension cable (power cord and extensions cannot be cut to length) One additional extension cable can be added.
- 24-volt: 60" power cord (power cord can be cut to length), wire lengths longer than 60" must be field supplied

Transformer Dimensions

- 12-volt: 3¼" wide x 2" deep (not including plug) x 1½" high (as you look at the plug in the outlet)
- 24-volt: 1¾" wide x 1⅝" deep (not including plug) x 2¾" high (as you look at the plug in the outlet)

NOTE: Due to the many variations of installations, wire management components are not included with your motorized shade system. There are numerous wire management products available at your local hardware store or home improvement center to help disguise the power cord when using a plug-in transformer. An example of a popular wire management accessory is wire channel. Wire channel is a vinyl sheathing that can be placed along the window casing or wall that will house and conceal exposed wiring for a clean and professional appearance.



Multi-Motor Power Supply

- Used when hard-wiring the transformer and direct wiring the motorized window coverings
- Each motor is "home run" wired back to the multi-motor power supply
- Power supply includes instructions and connection cables
- Must be mounted indoors, NEMA rated
- 120-volt AC 3.3 amp

Multi-Motor Power Supply Considerations

Transformer enclosure is generally mounted in an accessible indoor location such as a basement, utility closet, or garage. Motors are "home run" wired to the panel using 16-gauge wire.

- Dimensions: 12" wide x 6" deep x 12" high
- Additional wire may be purchased locally; up to 150 feet maximum

CAUTION: A licensed electrician is required for all line voltage electrical connections. All local and NEC codes must be followed.

12-Volt: 10 motor power supply kit available

24-Volt: 5 or 10 motor power supply kits available

DC Plug-In Transformer Considerations

- A power outlet must be within cord length to power motor
- Transformer power available for shade systems of any size or quantity

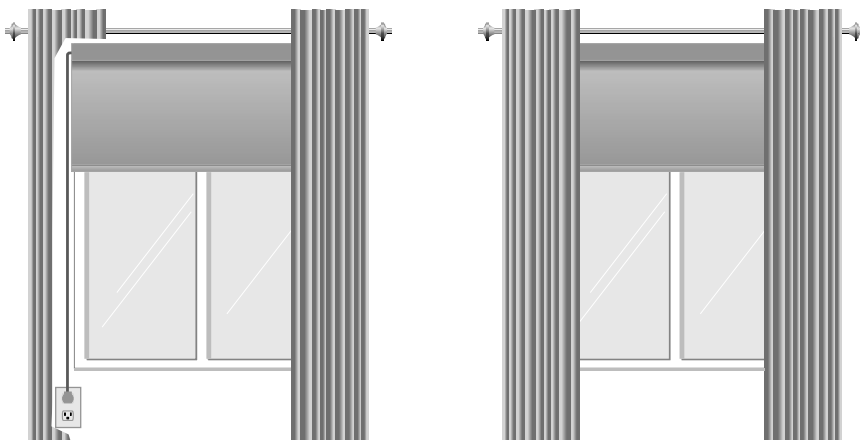

Options

Rechargeable Power Considerations

Shades will need charging on-site before installation.

Battery Autonomy (Years)																
Shade width (inches)																
	24	31	39	47	55	63	71	79	87	94	102	110	118	126	134	144
24	1.4	1.4	1.3	1.3	1.3	1.3	1.3	1.3	1.3	1.3	1.3	1.3	1.3	1.2	1.2	1.2
31	1.3	1.3	1.2	1.2	1.2	1.2	1.2	1.2	1.2	1.2	1.1	1.1	1.1	1.1	1.1	1.1
39	1.2	1.2	1.1	1.1	1.1	1.1	1.1	1.1	1.1	1.1	1.0	1.0	1.0	1.0	1.0	1.0
47	1.1	1.1	1.1	1.0	1.0	1.0	1.0	1.0	1.0	1.0	0.9	0.9	0.9	0.9	0.9	0.9
55	1.0	1.0	1.0	1.0	1.0	0.9	0.9	0.9	0.9	0.9	0.9	0.9	0.8	0.8	0.8	0.8
63	1.0	1.0	0.9	0.9	0.9	0.9	0.9	0.8	0.8	0.8	0.8	0.8	0.8	0.8	0.7	0.7
71	0.9	0.9	0.9	0.9	0.8	0.8	0.8	0.8	0.8	0.8	0.7	0.7	0.7	0.7	0.7	0.7
79	0.9	0.9	0.8	0.8	0.8	0.8	0.7	0.7	0.7	0.7	0.7	0.7	0.7	0.6	0.6	0.6
87	0.8	0.8	0.8	0.8	0.7	0.7	0.7	0.7	0.7	0.7	0.6	0.6	0.6	0.6	0.6	0.6
94	0.8	0.8	0.7	0.7	0.7	0.7	0.7	0.6	0.6	0.6	0.6	0.6	0.6	0.6	0.5	0.5
102	0.8	0.7	0.7	0.7	0.7	0.6	0.6	0.6	0.6	0.6	0.6	0.5	0.5	0.5	0.5	0.5
110	0.7	0.7	0.7	0.7	0.6	0.6	0.6	0.6	0.6	0.5	0.5	0.5	0.5	0.5	0.5	0.5
118	0.7	0.7	0.6	0.6	0.6	0.6	0.6	0.5	0.5	0.5	0.5	0.5	0.5	0.4	0.4	0.4
126	0.7	0.6	0.6	0.6	0.6	0.5	0.5	0.5	0.5	0.5	0.5	0.4	0.4	0.4	0.4	
134	0.7	0.6	0.6	0.6	0.5	0.5	0.5	0.5	0.5	0.4	0.4	0.4	0.4	0.4		
144	0.6	0.6	0.6	0.5	0.5	0.5	0.5	0.5	0.4	0.4	0.4	0.4	0.4	0.4		

Options

120-Volt Power Considerations

120-volt motors utilize the home or building's line voltage. Below are some considerations when planning for power.

CAUTION: A licensed electrician is required for all electrical connections. All local and NEC codes must be followed.

Radio Frequency 120-Volt 3-Wire Motors

Radio frequency-controlled motors are either hard-wired or plugged into line voltage. Any variety of RF controls can be used to achieve your desired control scenarios: remotes, wall switches, or timers. When installing a radio frequency-controlled line voltage motor, you have three options for electrical connection:

1. 3-prong plug: Plug into a prewired outlet. This is the simplest method; however, it requires the outlet be located within range of the motor cord. Do not use an extension cord.
2. Junction box lead: Use a junction box lead that can be hardwired to a nearby junction box. Requires the junction box to be located within range.
3. Custom plug plate: Plate to be installed nearby single gang junction box using the quick disconnect prewired to motor lead. Option best suited for commercial projects.

Interior Radio Frequency 120-Volt 3-Wire Power Options

- 3 foot power cord with 3-prong plug
- 10 foot power cord with 3-prong plug
- 3 foot motor lead with 8 foot junction box lead and quick disconnect
- 10 foot motor lead with quick disconnect and plug plate
- 3 foot motor lead with quick disconnect and plug plate

Exterior Radio Frequency 120-Volt 3-Wire Power Options

- 10 foot power cord
- 10 foot power cord with 3-prong plug (field attached)

Standard 4-Wire 120-Volt Motors

When installing a standard line voltage motor, both power and control are hard-wired to the motor. Control is provided via wall switches or dry contact outputs provided by certain home and building automation packages. Standard motor configuration options are:

Standard Motor Options

- 18 inches motor lead with 8 foot junction box lead and quick disconnect
- 18 inches motor lead with quick disconnect and plug plate
- 10 foot motor lead with quick disconnect and plug plate





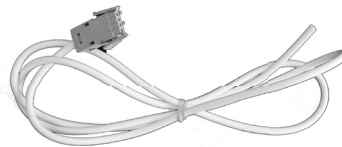

Plug Plate



Junction (j-box) lead





Options

Motorized Graber® Blinds and Shades feature Somfy® Radio Frequency Motors and Accessories. All Somfy Radio Frequency Motors utilize Somfy's Proprietary Protocol Radio Technology Somfy® (RTS).

Radio Frequency Controls (RTS range 65 feet)			
	<p>Situo Handheld Remotes</p> <ul style="list-style-type: none"> • Compatible with all Somfy RTS motors • Used to control single blinds/shades on each channel or group blinds/shades performing the same function • Battery included (CR 2032) • Remote includes convenient mounting hardware for hanging when not in use • Controls unlimited number of motors <table style="width: 100%; border: none;"> <tr> <td style="width: 50%; vertical-align: top; padding: 5px;"> <p>Situo 1, Single-Channel Remote Available colors:</p> <ul style="list-style-type: none"> • Interior: White, Silver </td> <td style="width: 50%; vertical-align: top; padding: 5px;"> <p>Situo 5, Five-Channel Remote Available colors:</p> <ul style="list-style-type: none"> • Interior: White, Silver </td> </tr> </table>	<p>Situo 1, Single-Channel Remote Available colors:</p> <ul style="list-style-type: none"> • Interior: White, Silver 	<p>Situo 5, Five-Channel Remote Available colors:</p> <ul style="list-style-type: none"> • Interior: White, Silver
<p>Situo 1, Single-Channel Remote Available colors:</p> <ul style="list-style-type: none"> • Interior: White, Silver 	<p>Situo 5, Five-Channel Remote Available colors:</p> <ul style="list-style-type: none"> • Interior: White, Silver 		
	<p>Telis 16, Sixteen-Channel Handheld Remote</p> <ul style="list-style-type: none"> • Compatible with all Somfy RTS motors • Used to control a single blind/shade on each channel or group blinds/shades performing the same function • Convenient display provides easy identification of shade(s) being controlled • Battery included (2 AAA) • Remote includes convenient mounting hardware for hanging when not in use • Controls unlimited number of motors <p>Available colors:</p> <ul style="list-style-type: none"> • Interior only: White 		
	<p>Situo 5 Variation Handheld Remote</p> <ul style="list-style-type: none"> • Compatible with all Somfy RTS motors • Used to control a single blind/shade on each channel or group blinds/shades performing the same function • Scroll interface allows for precise adjustment for blinds/shades, ideal for fine control horizontal blinds, layered, and sheer shades • Battery included (CR 2032) • Controls unlimited number of motors <p>Available colors:</p> <ul style="list-style-type: none"> • Interior only: White 		
	<p>DecoFlex Wireless Wall Switches</p> <ul style="list-style-type: none"> • Compatible with all Somfy RTS motors • Used to control a single blind/shade on each channel or group blinds/shades performing the same function • Switches include button labels and mounting hardware to flush mount in drywall (wireless) • Battery included (CR 2450) • Controls unlimited number of motors <table style="width: 100%; border: none;"> <tr> <td style="width: 50%; vertical-align: top; padding: 5px;"> <p>Single-Channel Wall Switch Available colors:</p> <ul style="list-style-type: none"> • Interior: White </td> <td style="width: 50%; vertical-align: top; padding: 5px;"> <p>Five-Channel Wall Switch Available colors:</p> <ul style="list-style-type: none"> • Interior: White, </td> </tr> </table>	<p>Single-Channel Wall Switch Available colors:</p> <ul style="list-style-type: none"> • Interior: White 	<p>Five-Channel Wall Switch Available colors:</p> <ul style="list-style-type: none"> • Interior: White,
<p>Single-Channel Wall Switch Available colors:</p> <ul style="list-style-type: none"> • Interior: White 	<p>Five-Channel Wall Switch Available colors:</p> <ul style="list-style-type: none"> • Interior: White, 		





Options

Motorized Graber® Blinds and Shades feature Somfy® Radio Frequency Motors and Accessories. All Somfy Radio Frequency Motors utilize Somfy's Proprietary Protocol Radio Technology Somfy® (RTS).

Specialty Radio Frequency Controls	
	<p>Telis 1 Chronis RTS Timer</p> <ul style="list-style-type: none"> Compatible with all Somfy RTS motors Used to control a single blind/shade or group of blinds/shades performing the same function Schedule one open and one closed function per day with different scheduled operation for weekend and weekdays Convenient display provides easy identification of shade(s) being controlled Battery included (2 AAA) Remote includes convenient mounting hardware for hanging when not in use Controls unlimited number of motors <p>Available colors:</p> <ul style="list-style-type: none"> Interior only: White
	<p>Situo 5 Soliris</p> <ul style="list-style-type: none"> Compatible with all Somfy RTS motors Used to control a single blind/shade on each channel or group blinds/shades performing the same function Battery included (CR 2032) Remote includes convenient mounting hardware for handing when not in use Controls unlimited number of motors <p>Available colors:</p> <ul style="list-style-type: none"> Interior only: White
	<p>Sunis Sun Sensor</p> <p>The Somfy Sunis RTS Sun Intensity Sensor is a wireless transmitter compatible with RTS motorized window coverings. Window or sill mounted, the Sunis RTS operates motorized window coverings in accordance to the sun intensity. Sensitivity (threshold) settings can be adjusted to accommodate various sunlight intensity and room temperatures to provide the ultimate in comfort and protection from harmful UV rays.</p> <p>The Somfy Sunis RTS controller communicates with all Somfy RTS controllable devices. The Sunis is a wireless, battery-powered, single-channel RF programmable controller for an unlimited number of Somfy RTS motors. All motors assigned to the Sunis will operate simultaneously. When used with the Somfy RTS shade motors, the Sunis will open or close the shades based on the amount of sun reaching the sensor.</p> <ul style="list-style-type: none"> Two-position suction cup mounting Mounts to glass or windowsill Battery included (CR 2450) Controls unlimited RTS motors Controls RTS motors based on sun intensity Operating temperature: 32°F to 140°F INDOOR USE ONLY Dimensions: 2 3/16" diameter x 3/4" deep
	<p>(RTS) Repeater – Range Expander</p> <p>The Repeater extends the range of all Somfy RTS controllers. Devices or motors that might have been previously out of range from an RTS transmitter can now be controlled by adding the RTS Repeater. The RTS Repeater should be placed approximately halfway between the RTS Somfy motor and controller. An LED is provided for confirmation that the unit is receiving the RTS. Repeater has the same typical range of other transmitters at approximately 65 feet and plugs directly into any household AC outlet.</p> <ul style="list-style-type: none"> Communicates with all Somfy (RTS) devices/motors Range expander: strengthens and extends the radio frequency signal (RTS) from control to motor Plug and play: plugs directly into any AC-Outlet; no programming needed LED feedback Controls unlimited number of shades simultaneously Dimensions: 2 1/8" wide x 4 1/8" high x 1.275" deep (without antenna)







Options

Motorized Graber® Blinds and Shades feature Somfy® Radio Frequency Motors and Accessories. All Somfy Radio Frequency Motors utilize Somfy's Proprietary Protocol Radio Technology Somfy® (RTS).

Integration Devices	
	<p>16-Channel Z-WAVE to RTS Bridge (ZRTSI II)</p> <p>The ZRTSI II is a Z-Wave to RTS Interface which acts as a bridge controller between a Somfy RTS motor and Z-Wave network. It receives Z-Wave transmissions and converts them to motor control commands for wireless controlled motors. Each ZRTSI II is plugged into an active electrical outlet and has sixteen (16) RTS channels. Each channel can control one individual or one group of RTS motorized window coverings.</p> <ul style="list-style-type: none"> • Allows Z-Wave controllers to operate Somfy RTS motors • 16 Channels of RTS control • Can be controlled with Z-Wave only • 65 foot RTS range • Plugs into wall outlet • Dimensions: 2¾" wide x 5½" high x 1½" deep (not including plug)
	<p>Universal RTS Interface (URTSI II)</p> <p>The addressable Universal RTS Interface can be used to communicate between home automation or other third party systems and all Somfy (RTS) motors and controls. It is capable of individual or group control and can be operated via Infrared Remote, RS232, or RS485 serial communication. Once an input is activated, an RTS radio command is sent to the motorized window treatment. Up to 16 addressable channels are available.</p> <ul style="list-style-type: none"> • Used for third party integration of all Somfy RTS motors, including both line (120-Volt A/C) and low voltage systems • Converts IR/RS232/RS485 to control all Somfy Radio Frequency (RTS) motors • 65 foot RTS range • Power: 9-volt to 15-volt DC, 200mA draw for each universal interface—transformer included • Up to 16 URTSI II's can be used in one system
	<p>Single-Channel Dry Contact to RTS Interface (includes power cord)</p> <p>The Somfy Single-Channel RTS dry contact interface communicates with all RTS motors and can only be controlled by dry contact. It operates as a single-channel Telis remote controller, providing UP, DOWN and STOP functions along with a "MY" or customer-preferred shade setting. The RTS (RF) technology controls all RTS devices within a 65 foot range. This device is enclosed in a weatherproof mounting case for indoor and outdoor operation.</p> <ul style="list-style-type: none"> • Single-channel RTS control for all Somfy RTS motors • Controlled with dry contacts • Powered by 3-volt lithium battery (included) • Knockout holes in back and bottom of weatherproof case • Dimensions: 6" wide x 4¼" high x 2¼" deep
	<p>TaHoma™</p> <p>The TaHoma™ gateway is a smart home hub that allows control of up to 40 RTS and 50 Zigbee devices using the TaHoma North America app (available on iOS and Android). Using the app, users can send Zigbee and RTS commands, create scenes/routines, and schedules. Users can access TaHoma from anywhere via remote access. Though designed as a room controller, up to 10 TaHomas can combine within the same RTS system only for multi-zone control. TaHoma can also be used as a Wi-Fi to RTS/Zigbee interface for integration with third-party control systems. The TaHoma can be connected wirelessly or with an ethernet adapter shown below.</p> <ul style="list-style-type: none"> • Dimensions: 2.76" L x 2.76" W x 6.69" H
	<p>TaHoma Ethernet Adapter</p> <p>The TaHoma® Ethernet Adaptor adds an Ethernet LAN port to TaHoma, providing fast and stable internet connection.</p>

Options

Standard 4-Wire Motor 120-Volt Controls

	<p>Maintained DP-DT Paddle Switch</p> <ul style="list-style-type: none"> • Controls one or two shades as a stand-alone control • 120-volt A/C • Available colors: White, Ivory
	<p>Group Control System (GCS-II)</p> <p>The Group Control System-II (GCS-II) permits low voltage control of up to four Somfy® motors with one or more switches, from one or more locations. The GCS-II offers only group control, and does not have the capability of operating each motor individually. The Group Control System-II is UL and cUL approved.</p> <ul style="list-style-type: none"> • Enclosure measures 8" wide x 10" high x 4" deep • SP-DT paddle switch sold separately
	<p>Maintained SP-DT Paddle Switch</p> <ul style="list-style-type: none"> • Controls one shade as a stand-alone or in conjunction with a GCS-II multi-motor control for up to four motor operation • 120-volt A/C • Available colors: White, Ivory
	<p>IGC 4n1 Motor Group Control</p> <ul style="list-style-type: none"> • Control up to four WT motors individually or in groups • Provides default intermediate positions: 25%, 50%, 75% openness • Three customizable intermediate positions per motor • Individual control and master control using DecoFlex IGC/4N1 Keypads • Four keypad ports and two master ports • IGC 4n1 switch sold separately
	<p>RTS to IGC 4n1 Receiver</p> <ul style="list-style-type: none"> • Receiver allows RTS remotes to be added to the standard four wire motor control and motors
	<p>IGC 4n1 Switch</p> <ul style="list-style-type: none"> • Designed to be used with the IGC 4n1 motor group controller • Six button control, three intermediate positions, up, stop, and down • Available colors: White
	<p>Motor Tester Cable</p> <p>The motor tester cable is used for any 120-volt motor with the wago quick disconnect. The cable allows adjusting limits on standard motors and can provide alternate power for radio frequency and intelligent motors. Motor tester cable includes switch and wago quick disconnect plug.</p> <ul style="list-style-type: none"> • Dimensions 2.5" wide x 3" high x 2" deep

GRABER®

Grabber is a brand of Springs Window Fashions, the Best Experience Company

Grabber and the Grabber logo are registered trademarks of Springs Window Fashions, LLC.

(10/23) 23-499350

GRABER.

Graber Motorization

Designer US Price List — Effective January 2024

Radio Frequency (RF)

Power Source: Choose one (1) Power Source per motor. For motorized lift dual shades, one (1) motor and one (1) power source are required for each motorized shade (total of two motors and two power sources if both shades of the dual shade are motorized lift).

RTS Motor and Accessory Pricing

A. RTS Motor Pricing

Add price of motor to blind or shade price.

12 Volt RF Motor Options

Lift Motor	
Cellular, Pleated, or Fresco Roman Shades: 12V CL32 RTS Motor (2) (price per panel)	462
Tilt Motor	
Aluminum, Composite, Vinyl or Wood Blinds (except 1" (2.5 cm)): Cord lift with Motorized Tilt (F)	384
Composite, Vinyl or Wood Blinds (except 1" (2.5 cm)): Ring lift with Motorized Tilt (M)	384
Roller Motor	
Layered Roller, Sheer, Solar Shades: 12V Sonesse 28 RTS WF Ext Batt	467
Roller, Solar Shades: 12V Sonesse 28 RTS WF Li-ion	633
Roller, Solar Shades: 12V Sonesse 30 Ultra RTS WF Li-ion	733

NOTE: For motorized lift dual shades, price one motor for each motorized shade (total of 2 motors); Dual shade is not available with 12V Sonesse 28 RTS WF Li-ion or 12V Sonesse 30 Ultra RTS WF Li-ion motors.

24 Volt RF Motor Options

Roller Motor	
Roller, Artisan Roman, Solar, Woven Wood Shades*: 24V Son30 RTS Non-Rechargeable Motor (16)	896

* Woven Wood Shade price is per panel

120 Volt RF Motor Options

Roller Motor	
Roller, Solar Shades: 120V ST40 RTS Motor (4); add power source below	1058
Choose one power option below	
3 Foot (91.4 cm) Motor Lead and 3-Prong Plug	53
3 Foot (91.4 cm) Motor Lead and 8 1/2 Foot (259.1 cm) J-Box Lead with Quick Disconnect	105
3 Foot (91.4 cm) Motor Lead with Quick Disconnect and Plug Plate	118
10 Foot (304.8 cm) Motor Lead and 3-Prong Plug	147
10 Foot (304.8 cm) Motor Lead with Quick Disconnect and Plug Plate	150

NOTE: 3-prong exterior plug price below and remote pricing on following charts.

B. Motorization Power Sources

Choose one (1) power supply per motor or select multi-motor power supply.

NOTE: Power supply is per motor/panel

12 Volt External Battery Non-Rechargeable Power Options

Battery Tubes for Somfy RTS Motors

(CL32 and Tilt Motors)

Tube No Batteries	69
Tube With Batteries (Includes 8 AA lithium batteries)	135
Dual Tubes No Batteries	155
Dual Tubes with Batteries (Includes 16 AA lithium batteries)	287
DC Transformer Single Motor (includes 96" (243.9 cm) extension)	125
Other 12 Volt External Battery Non-rechargeable Power Options	
Extension Cable - 48" (122.0 cm)	21
Extension Cable - 96" (243.9 cm)	26
12V Multi Motor Power Panel	1235
10 Motors—Up to 10 Motors Per Power Supply; includes motor connection lead	

NOTE: Dual tubes not available with horizontal products. Review power considerations for best performance.

12 Volt Li-ion Rechargeable Power Options

Rechargeable Battery Pack for Somfy RTS Roller Motor

(12V Sonesse 28 RTS External Battery Motor)

Rechargeable Li-ion Battery Pack	157
Li-ion Charger	53

24 Volt Power Options

24V Transformer Single Motor - 5 Foot (152.4 cm) Power Cord	155
24V Multi Motor Power Panel	1427
5 Motors—Up to 5 Motors Per Power Supply; includes motor connection lead	
24V Multi Motor Power Panel	2103
10 Motors—Up to 10 Motors Per Power Supply; includes motor connection lead	

120 Volt Exterior Power

120 Volt Exterior Electrical 3-Prong Plug: 15 Amp	61
---	----

C. Radio Frequency Motorization Controls

Choose one or more controls per order. Controllers are wire-free and battery is included. Multi-channel remotes and Channel Assignments should be entered in the Motorization Control Product ID option.

Radio Frequency Remote Controls	
Situo 1 Single-Channel RTS Remote: White	125
Situo 1 Single-Channel RTS Remote: Silver	204
Telis 1 Single-Channel Exterior RTS Remote: White/Blue	155
Situo 5 Five-Channel RTS Remote: White	168
Situo 5 Five-Channel RTS Remote: Silver	229
Telis 4 Five-Channel Exterior RTS Remote: White/Blue	170
Situo 5 Five-Channel Variation Remote: White	607
Telis 16-Channel Remote: White	682
Radio Frequency Wall Switches	
DecoFlex Single-Channel Wall Switch: White	324
DecoFlex Five-Channel Wall Switch: White	356
Specialty Radio Frequency Controls	
Telis 1 Chronis RTS Timer: White	665
Situo 5 Five-Channel Soliris RTS Remote: White	794
Sunis RTS Sun Sensor	539
Radio Frequency Repeater (plug-in)	675
RTS Wind Sensor (includes exterior power cord with 3-prong plug)	607
Integration Devices	
ZRTSI II: 16-Channel Z-Wave to RTS Bridge	255
URTSI II: Universal RTS Bridge	1498
Single-Channel Dry Contact to RTS Interface	276
TaHoma Zigbee Bridge	572
TaHoma Ethernet Adapter	89

NOTE: The integration devices cannot be the sole controller for motorized window treatment(s). A remote, wall switch, or timer is needed with your window treatment(s).

120 Volt Standard Motor

NOTE: 120 volt power options included with motor selection.

Motor Pricing

A. 120 Volt Standard Motor Pricing

Add price of motor to shade price

12 Volt RF Motor Options

Roller and Solar Shades: 120V ST40 STD Wired Motor (5); add power source below	730
Choose one power option below	
18 Inches (45.8 cm) Motor Lead and 81/2 Foot (304.8 cm) J-Box Lead with Quick Disconnect	137
18 Inches (45.8 cm) Motor Lead with Quick Disconnect and Plug Plate	124
10 Foot (3.048M) Lead with Quick Disconnect and Plug Plate	208

B. 120 Volt Standard 4-Wire Control Options

Choose the control option you desire.

Standard control options provide up, down, and stop operation of the shades only. When grouping multiple shades, the entire group will go up and down together. For individual shade control within groups or to set intermediate settings, choose from the IGC 4n1 control options below.

1–2 Motors

Maintained Double Throw/Double Pull Paddle Switch with Face Plate—White or Ivory	157
--	-----

Group Control Systems

Group of Shades Operating Together	
Group Control System (GCS-II); up to four (4) motors	1052
Maintained Single Throw/Double Pull Paddle Switch with Face Plate—White or Ivory	93
Individual and/or Group of Shades Operation	
IGC 4n1 Group Controller; up to four (4) motors	1386
IGC 4n1 Switch—White	180
IGC 4n1 RTS to IGC Receiver	607

Troubleshooting Tool

Motor Limit Set Switch W Wago Plug	423
------------------------------------	-----