

<u>Table of Contents</u>	<u>Page</u>
a. Features & Benefits	NT a-1
b. Colors & Louvers	NT b-1
c. Stiles	NT c-1
d. Panel Configurations	NT d-1
e. Frame Styles	NT e-1
f. General Product Specifications	NT f-1
g. Tilt Rods	NT g-1
h. Divider Rails	NT h-1
i. Hardware	NT i-1
j. Track Shutters	NT j-1
k. Special Options	NT k-1
l. Specialty Shapes	NT l-1
m. Pricing, Options & Surcharges	NT m-1
n. Appendix	NT n-1

Features and Benefits

- Made of hand-selected NormanTeak[™] that is treated with **Prescription Wood Conditioning[™]** technique according to the moisture content of the final installation location to reduce post-installation shrinking and swelling.
- Louvers are made of **quarter-sawn wood** to ensure generations of durability. This tight, straight and parallel grain also enriches wood character in stain finish.
- The appearance of **furniture quality finish** and the **exceptional craftsmanship** gives Norman Teak shutters an instant feeling of art.
- A wide range of **frame designs**, that keep installation screws out of sight for a clean and decorative look.
- **Reinforced engineered stile**-- Multiple layers of wood bonded together to reinforce durability to the core of the stile, which results in a robust support system for the shutter panel.
- Employs **mortise and tenon joinery** that resists shear and racking forces endured by shutters to ensure prolonged quality and durability.
- **Multiple stile options** available in various sizes to accommodate different window designs. Use **Astragal** or **Rabbet stile** as a natural light block between panels.
- Quick and easy on-site installation with the **pre-installed magnets and hinges**, as well as **pre-mitered frames** and **slotted keyholes**.
- A labor-intensive **hand finishing** process that involves **multiple sanding and coatings** with fine layers of stain or paint to achieve a translucent and polished appearance.
- **Special panel and frame design** that is custom cut to accommodate unique windows. Create unity or attract attention with Sussex's exclusive decorative elements.
- Personalize shutters with **special options**. Choose from fixed louvers, center or offset tilt rod, double hung panels, café shutters, track systems, French door cutout, specialty shapes and many more.
- Available in a **multitude of solid and stain colors** that can match the style of any home.
- A guarantee of Norman's exemplary quality with a **lifetime limited warranty on materials and workmanship**.

Colors & Louvers

Solid		Stain**	
001 Pure White	019 String	108 Rustic Gray	230 Old Teak
003 Silk White	030 Moondust	110 Limed White	231 Spring Rose
004 Bright White	032 Sea Mist	114 Taupe	232 Red Mahogany
006 Pearl	046 Ice	200 Natural	233 Dark Mahogany
007 Ivory Lace	048 Chai	202 Golden Oak	237 Wenge
008 Marshmallow	049 Stone Grey	204 Oak Mantel	242 Auburn
009 Creamy	051 Brown Grey	205 Goldenrod	247 Bark
011 Cameo	053 Clay	206 Pecan	248 Pretzel
012 Crisp Linen	063 Decorators White	211 Cherry	249 Acorn
013 Bisque	836 Classic Black	212 Dark Teak	250 Sumatra
016 Butter		214 Cocoa	251 Raisin
Louver		215 Cordovan	252 Toffee
Elliptical	1 ¼"	219 Mahogany	
	1 7/8" ♦*	220 New Ebony	
	2 ½" ♦	221 Black Walnut	
	3 ½" ♦	227 Red Oak	
	4 ½" ♦	229 Rich Walnut	
Optimal [™] *			
Optimal [™] safeguards your window treatments from accumulating airborne germs and disease-causing bacteria so that you have on less thing to worry about.			

♦ Sandblasted finish is also available for 1 7/8", 2 ½", 3 ½" and 4 ½" louver sizes.

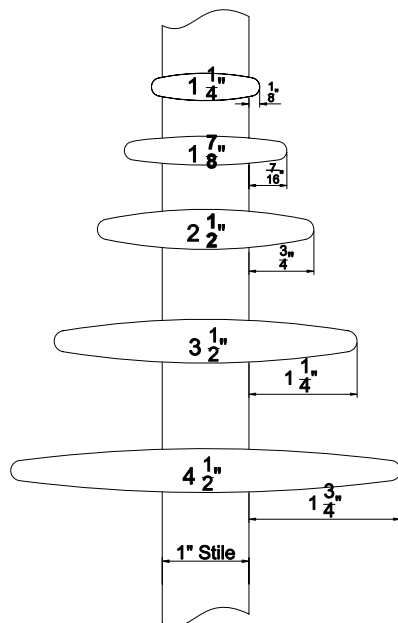

**Stiles
Options**

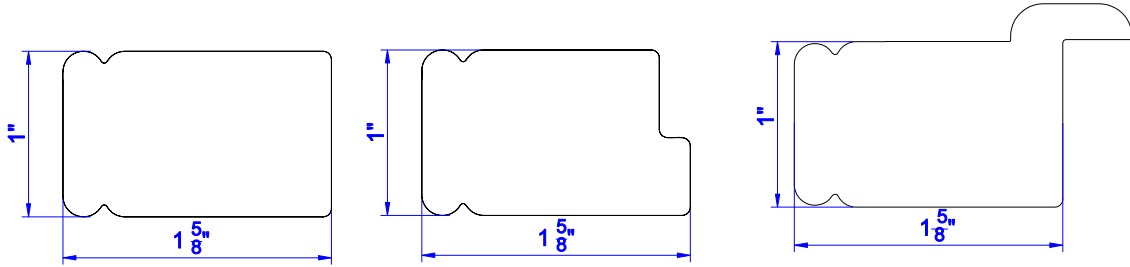

1 5/8" Butt Stile

1 5/8" Rabbet Stile

1 5/8" Astragal Stile

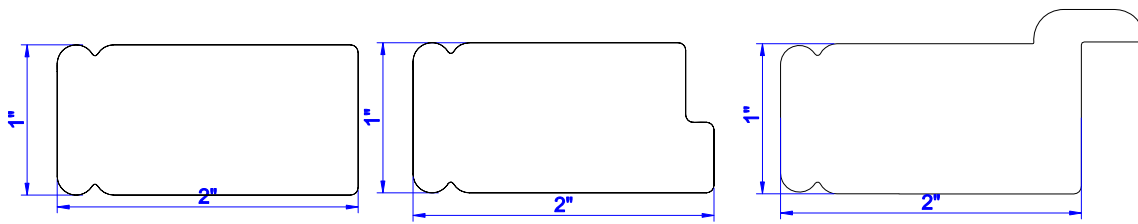

2" Butt Stile

2" Rabbet Stile

2" Astragal Stile

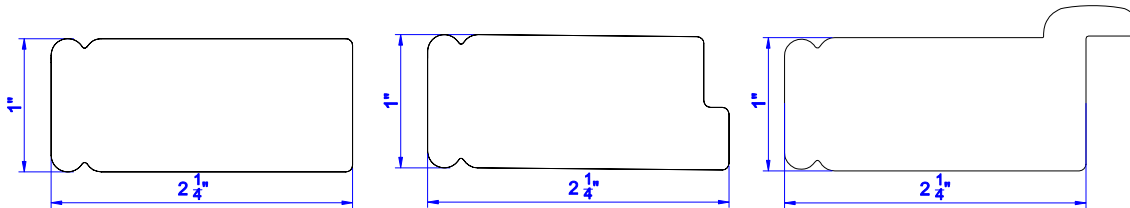

2 1/4" Butt Stile

2 1/4" Rabbet Stile

2 1/4" Astragal Stile

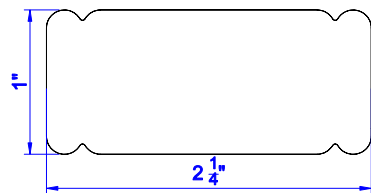

2 1/4" Center Stile

Stile between panel closure

Single panel

I) Panel width < 9"

- Rabbeted stile (Deco frame, L frame, Z frame and Hang strip beside panel)
 - 1 ⁵/₈"
 - 2" (default)
- Butt stile only (Hang strip behind panel)
 - 1 ⁵/₈"
 - 2" (default)

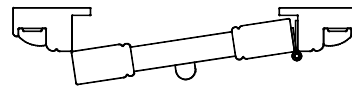
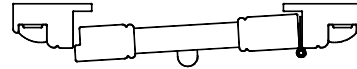

II) Panel width ≥ 9"

- Butt stile only
 - 1 ⁵/₈" (Optional for panel width ≤ 12")
 - 2" (default)

2 panels or more

- Astragal stile
 - 1 ⁵/₈" (Optional for panel width ≤ 12")
 - 2" (default)
- Rabbet stile
 - 1 ⁵/₈" (Optional for panel width ≤ 12")
 - 2"

Panel Configurations

Single Panel

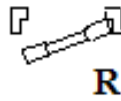

OR

Two Panels



LR



LL



RR

Three Panels

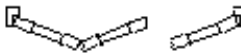

LLR

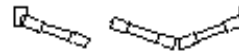

LRR

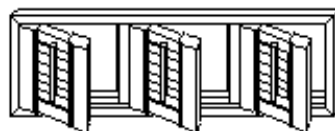

LTLTL

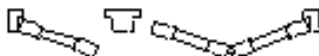
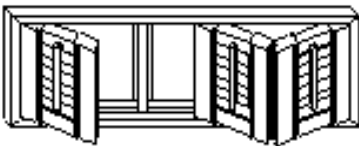

LTRR

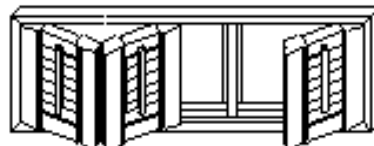

LLTR

Panel Configurations (continued)

Four Panels

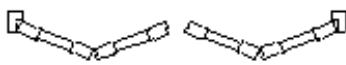

LLRR

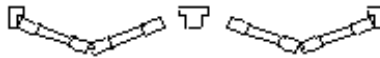
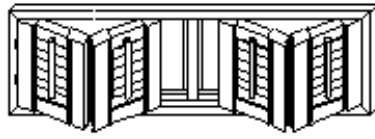

LLTRR

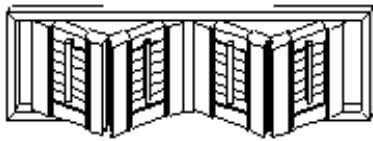

RRILL



LTLRTR

Six Panels

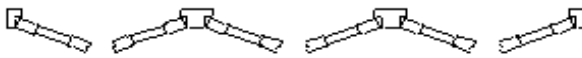
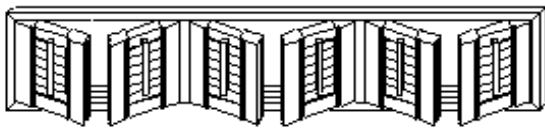

LRTLRTL



LLTLRTRR

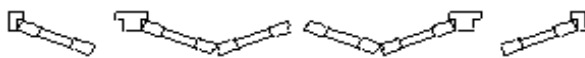

LTLRRTLR

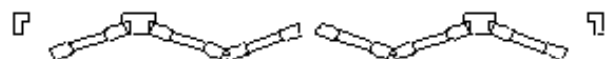
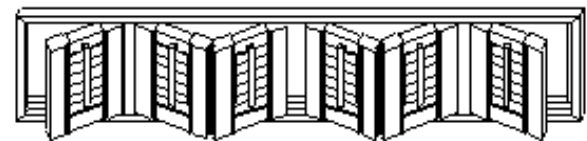

RTLRLRTL

Panel Configurations – Astragal stile

◇ 2 Panels – LR/LL/RR

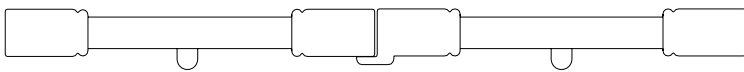

◇ 3 Panels - LRR

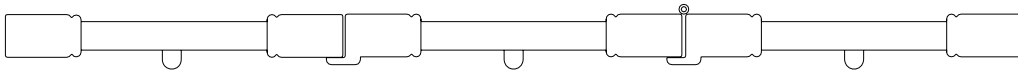

◇ 3 Panels – LLR

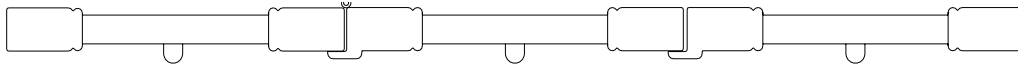

◇ 4 Panels - LLRR

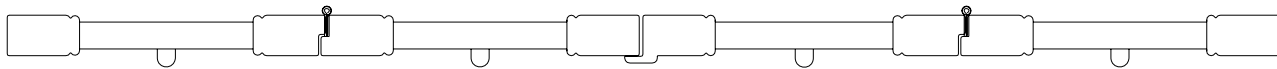

Norman Teak Shutters

Frame Styles

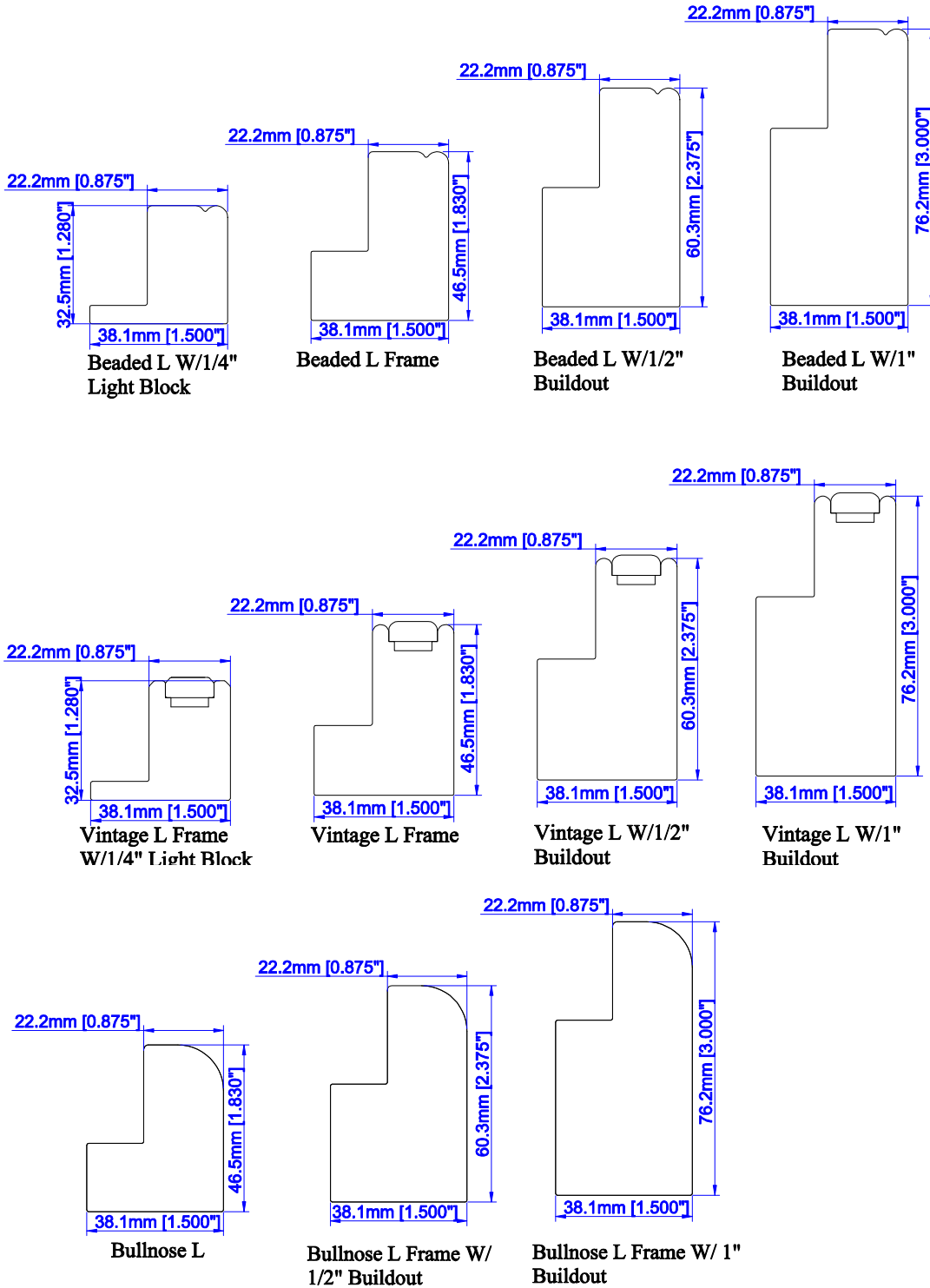

Also available

- o Custom extensions* up to 2" for L frames

* Surcharge applies. Please see Options and Surcharges page for details. NT e-1

Frame Styles

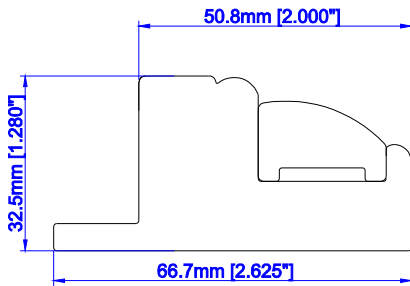

2" Camber Deco Frame

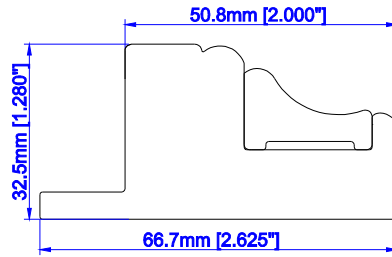

2" Classic Deco Frame

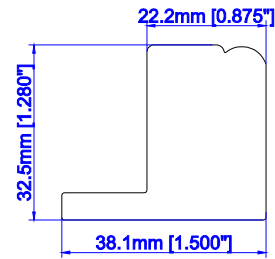

2" Deco Sill Plate

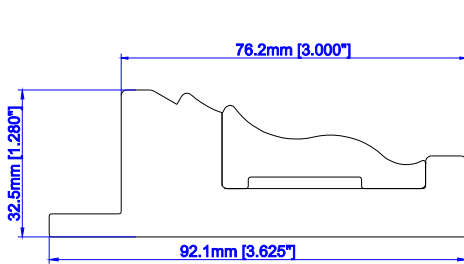

3" Ridge Deco Frame

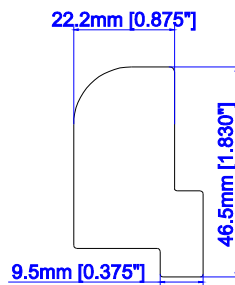

Tilt Out Z Frame

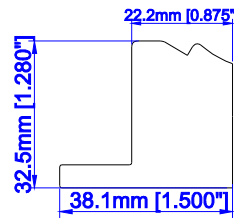

Ridge Deco Sill Plate

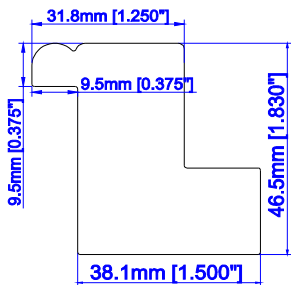

1 1/4" Beaded Z Frame

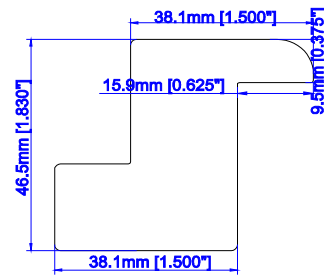

1 1/2" Bullnose Z Frame

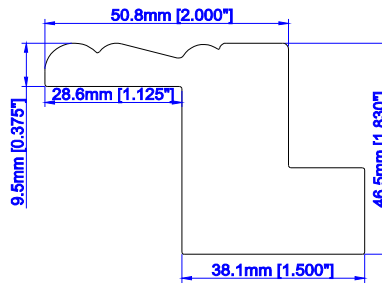

2" Bel Air Z Frame

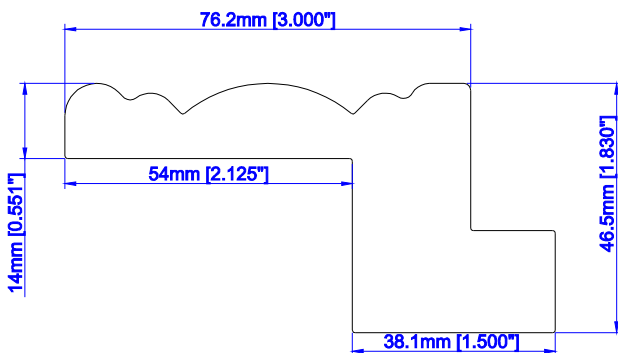

3" Crown Z Frame

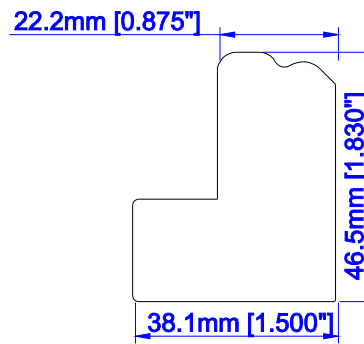

3" Crown Z Sill Plate

Also available

- Custom extensions* up to 1" for Z frames
- 1/2", 1" and 1 1/2" standard extensions* and custom extensions* up to 2" for Deco frames
- Custom extensions* up to 2" for hang strips (OM)

Norman Teak Shutters

Frame Styles

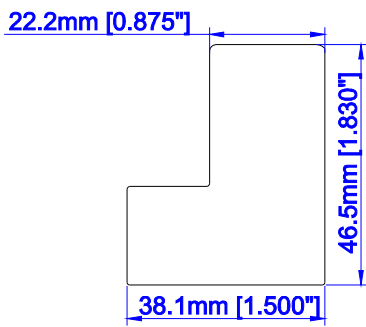

1 1/2" Bullnose Z
1 1/4" Beaded Z
Sill Plate

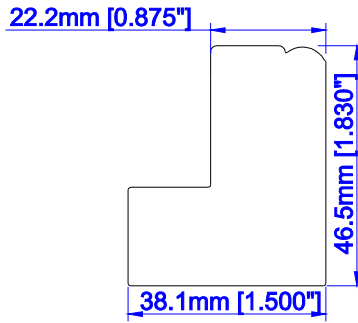

2" Bel Air Z Sill Plate

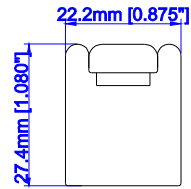

Vintage Hang Strip

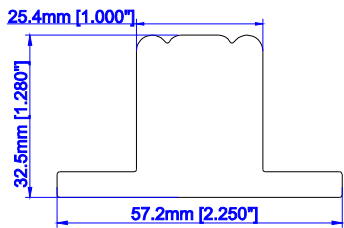

1" T Post W/ 1/4" Light Block
(Deco)

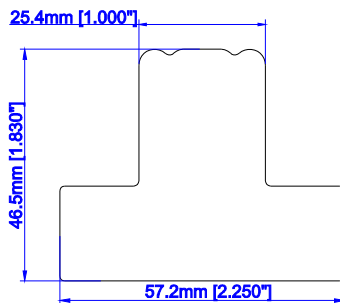

1" T Post W/ 3/4" Light Block
(L/Z/HS)

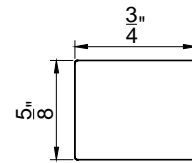

Light Block

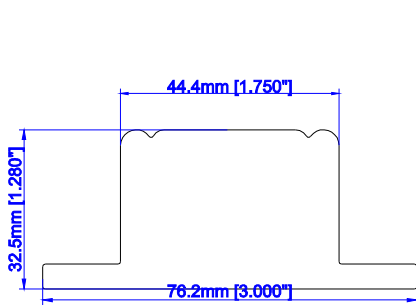

1 3/4" T Post W/ 1/4" Light
Block (Deco)

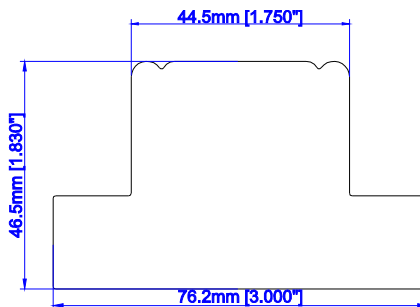

1 3/4" T Post W/ 3/4" Light
Block (L/Z/HS)

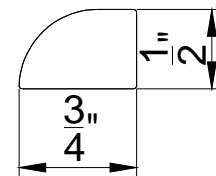

Scribe Trim

Norman Teak Shutters

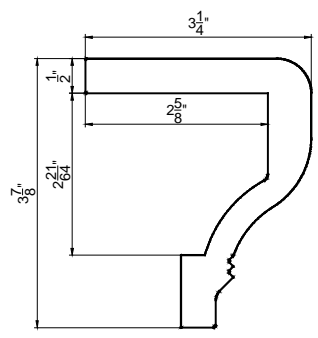
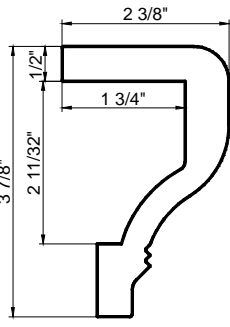
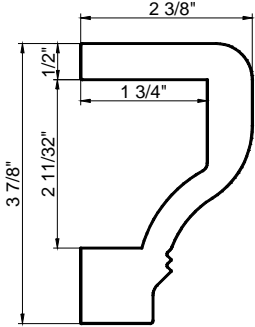

Curved Designer Sill Cap (L) Curved Designer Sill Cap (D/HS) Curved Designer Sill Cap (Z)

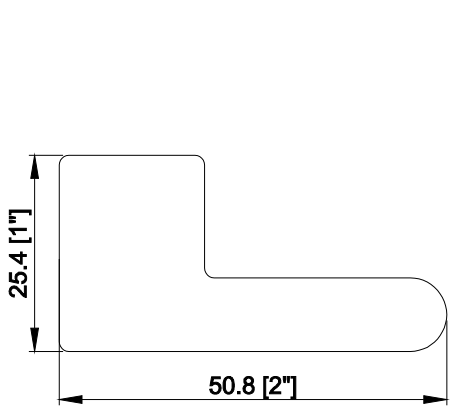

2" Sill Plate

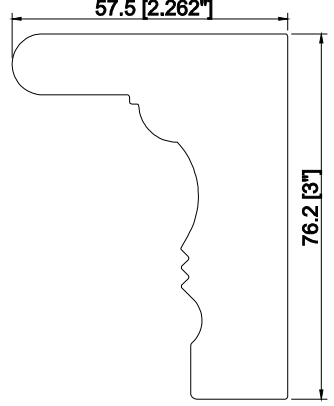

3" Sill Frame

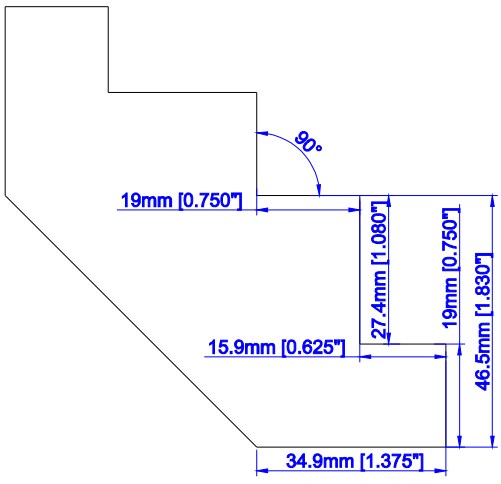

Corner Post W/ 3/4" Light Block (L/Z/HS)

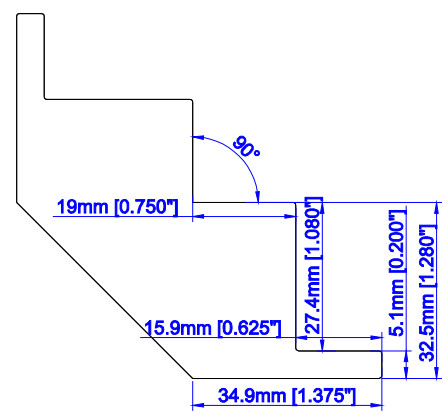

Corner Post W/ 1/4" Light Block (Deco)

Frame Styles

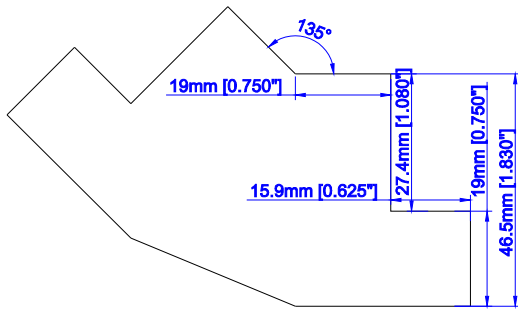

**Bay Post W/ 3/4"
Light Block (L/Z/HS)**

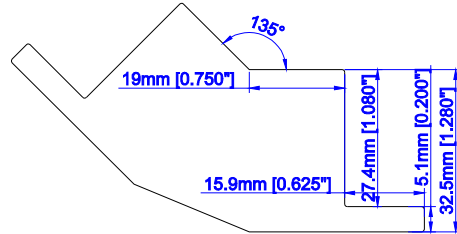

**Bay Post W/ 1/4"
Light Block (Deco)**

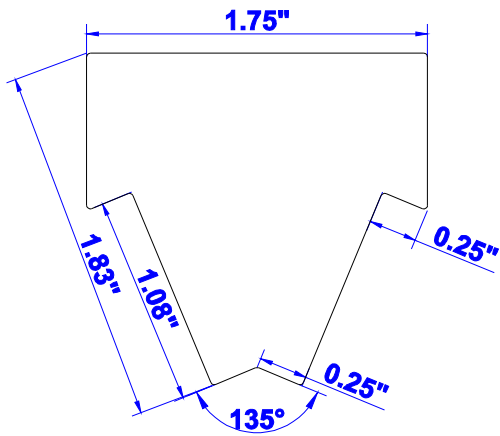

**Slim Fit Bay Post for 135 Degree
(L/Z/HS)**

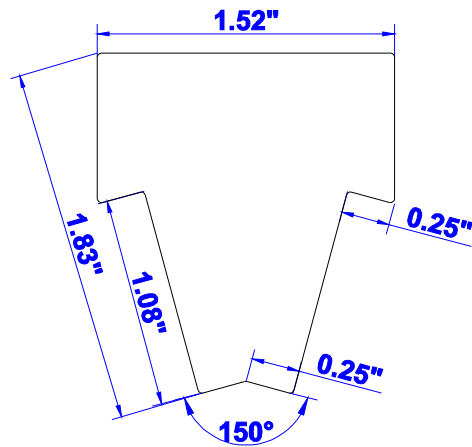

**Slim Fit Bay Post for 150 Degree
(L/Z/HS)**

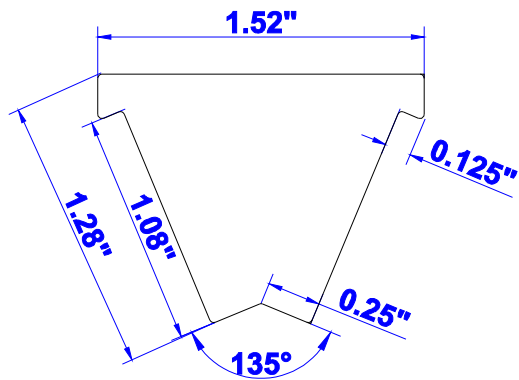

Slim Fit Bay Post for 135 Degree (D)

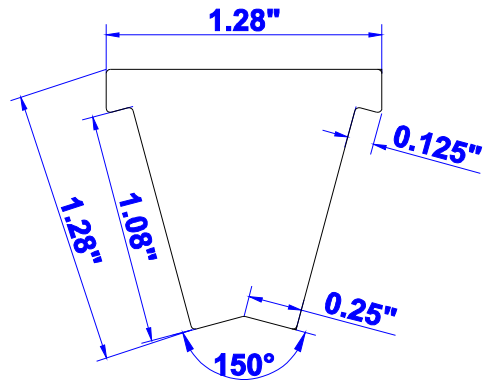

Slim Fit Bay Post for 150 Degree (D)

Frame Styles

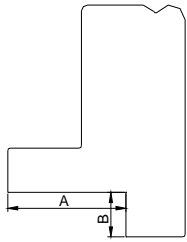

Notch Out
Beaded L Frame (A) *

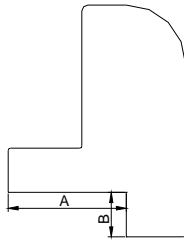

Notch Out
Bullnose L Frame (A) *

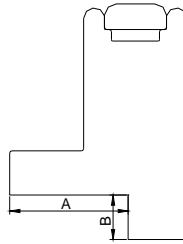

Notch Out
Vintage L Frame (A) *

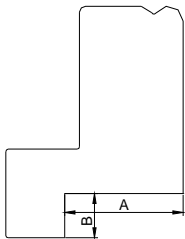

Notch Out
Beaded L Frame (B) *

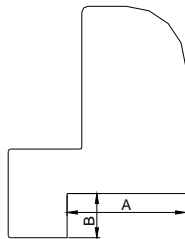

Notch Out
Bullnose L Frame (B) *

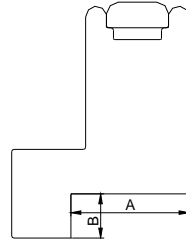

Notch Out
Vintage L Frame (B) *

Also available

- Custom width* up to 7½" for T Posts
- Custom angle bay posts*

* Surcharge applies. Please see Options and Surcharges page for details

Pre-drill L or Z Frames:

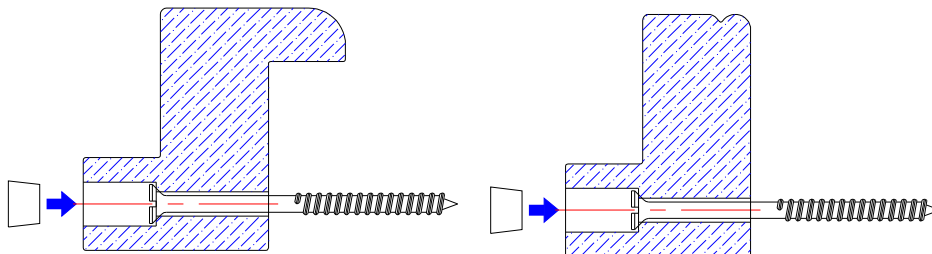

General Product Specifications

<u>Description</u>	<u>Minimum</u>	<u>Maximum</u>		
		1¼"	1⅞"	2½" / 3½" / 4½"
Single Panel Width (Regular)	6"	20"	30"	36" for 2½", 42" for 3½" & 4½"
Single Panel Width (Bi-fold)	6"	20"	26"	26"
Multi-fold Panels (hinged shutters, up to 4 panels)	6"	20"	N/A	N/A
Multi-fold Panels (track shutters, up to 4 panels)	6"	N/A	20"	20"
Single Panel Width (for Bypass Panel With Center Stile)	6"	N/A	30"-50"	36"-50"
Single Panel Height	10"	133"	133"	133"
Shutter Width (Without T Post)	N/A	4x single panel width (bifold) + frame		
Shutter Width (With T Post)	N/A	Unlimited (frame pieces exceeding 142" will be spliced)		
Shutter Height	N/A	133" + frame		

Shutters without bottom supports

Sussex shutters will be covered by our warranty for this application, subject to our standard specification limitations and the guidelines listed below:

All Sussex panel configurations:

- You must inform Norman Shutters of situations where shutters will not have bottom support when placing the initial order, or warranty will be considered void.
- Informing Norman Shutters when placing such orders ensures that the factory will add extra hinges to support the panel. This will reduce the probability of the panels sagging.
- If you fail to notify Norman Shutters that the shutter will be used without a bottom support or used as doors, this will constitute a misapplication of the shutter. Consequently, you will be responsible for the cost of any RGA Reorder that is submitted.
- If you want a bifold shutter, a track must be ordered to support the panels.

Tilt Rods

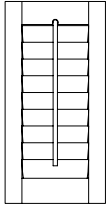

Standard Tilt Rod
Default Location

In the middle of the panel on front side (default).

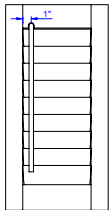

Offset Tilt Rod^{*}
Default Location

On the front side of the panel and at 1" from the louver ends on the hinged side.

Optional location: per your request.

InvisibleTilt[™] *

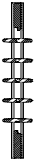
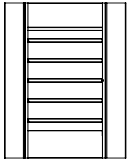

Louver tilting system embedded within panel stile. It is not available for 1 1/4" or 1 7/8" louver. The tilting system is split when the number of louvers exceeds the limits as listed below:

Louver Size	Maximum Possible Louvers	Height Range
2 1/2"	21	47 3/4" – 55 1/4"
3 1/2"	14	45 3/4" – 53 1/4"
4 1/2"	10	47 3/4" – 55 1/4"

- For even numbers of louvers, the number of louvers operated by the top and the bottom tilting system will be the same.
- For odd numbers of louvers, the number of louvers operated by the bottom tilting system will be one more than the number of louvers operated by the top tilting system.
- Minimum panel width is changed to 8 11/16"

Divider Rails

- A divider rail is an extra rail in the middle of the panel.
- Creates two sections in the panel so louvers can be operated independently.
- Strengthens the panel and enhances panel structural integrity.
- For 1¼" Colonial louver, divider rail is required for panel heights over 50".
- For other louver sizes, divider rail is required for panel heights over 78".

Specifications

- Standard width: 3"
- Default location: center of the panel unless specified otherwise

Measurements:

- Window size:
 - Measure from the bottom of the window to the center of the divider rail.
- Max frame-to-frame:
 - Measure from the bottom of the frame to the center of the divider rail.
- Position:
 - Per customer's specification. However, the divider rail may be adjusted to a lower or higher position, within our allowable deviation to ensure reinforcement and aesthetics of the shutter.

When placing the order, please clearly specify if the divider rail position needs to line up with that of other shutter divider rails in the same room. Please also refer to the table below for the allowable deviation details.

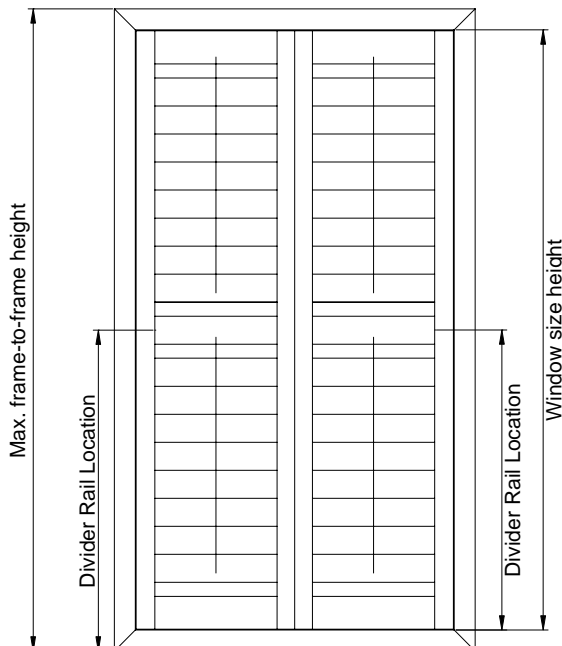

Divider rail allowable deviations

Louver Size	Allowable ± Deviation
1¼"	½"
1"	¾"
2½"	1"
3½"	1½"
4½"	2"

Hardware

Hinges

Self-Mortise Hinge

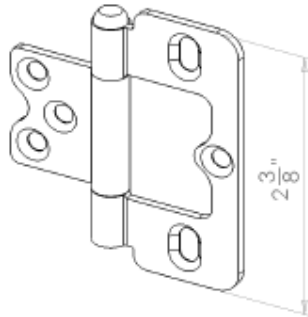

Bi-fold Hinge

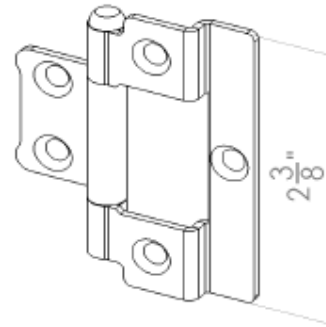

L Hinge

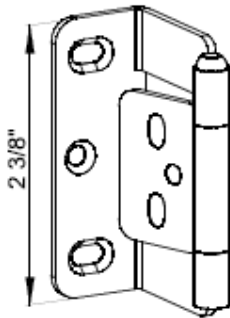

Hinges are available in :

Silk White, Bisque, Pearl, Bright Brass, Antique Brass, Black, Nickel plated and Stainless Steel *

* Surcharge applies. Please see Options and Surcharges page for details.

Invisible Hinge

Frame Options	Hinge	Notes
2" Camber Deco Frame	Y	/
2" Classic Deco Frame	Y	/
3" Ridge Deco Frame	N	/
Vintage L Frame W / 1/4" Light Block	N	/
Vintage L	N	/
Vintage L Frame w/ 1/2" Buildout	N	/
Vintage L Frame w/ 1" Buildout	N	/
Beaded L w 1/4"light block	Y	/
Beaded L	Y	/
Beaded L Frame w/ 1/2" Buildout	Y	/
Beaded L Frame w/ 1" Buildout	Y	/
Bullnose L	N	/
Bullnose L Frame w/ 1/2" Buildout	N	/
Bullnose L Frame w/ 1" Buildout	N	/
Tilt out Z Frame	N	/
1.25" Beaded Z Frame	Y	/
1.5" Bullnose Z Frame	Y	/
2" Bel Air Z Frame	Y	/
3" Crown Z Frame	N	/
7/8" Vintage Hang Strip (31mm) (27mm for 1" stile)	N	/
1" T-Post w/ 1/4" Light Block(for Deco)	Y	only available with hinge on one side, for example, LTL is available, but RTL is not.
1" T-Post w/3/4" Light Block(for L/Z/HS)	Y	
1 3/4" T-Post w/1/4" Light Block(for Deco)	Y	

1 3/4" T-Post w/3/4" Light Block(for L/Z/HS)	Y	
Corner Post w/1/4" Light Block(for Deco)	Y	/
Corner Post w/3/4" Light Block(for L/Z/HS)	Y	/
Bay Post w/1/4" Light Block(for Deco)	Y	/
Bay Post w/3/4" Light Block(for L/Z/HS)	Y	/

Invisible Hinge Qty	
Panel Height (H)	Hinge Qty
H<=48"	2
48"<H<=78"	3
78"<H<=96"	4
96"<H<=120"	5
H>120"	6

Available Stile: Butt and Astragal

Preinstallation:

Panels and frames will be packaged individually, and the hinge is preinstalled onto the frame/post, with the screws for the other half part on the panels in the hardware box.

If bifold/multi-fold panels are packaged together, the hinges are installed before shipping, or the hinges & screws are packed into the hardware box.

Panel Lock: (not available for 1.625" Stile)

Available Material: All

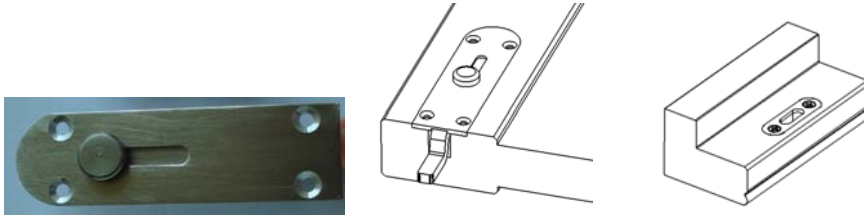

Position: (Only available on Bottom for Track Shutters with Bottom Track; For Regular, available on Top/Bottom/both Top and Bottom)

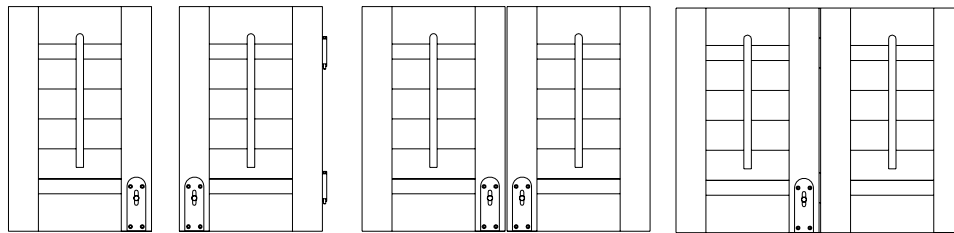

Panel Config: L Panel Config: R

Panel Config: LR

Panel Config: LL

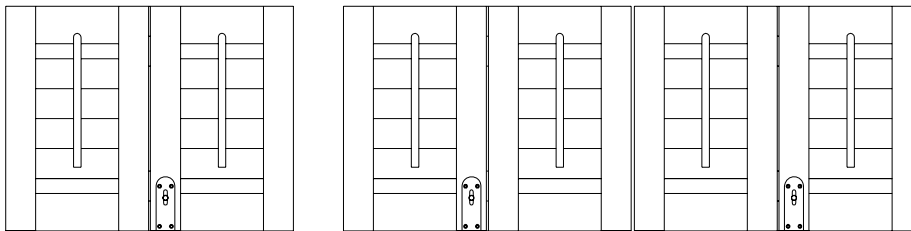

Panel Config: RR

Panel Config: LLRR

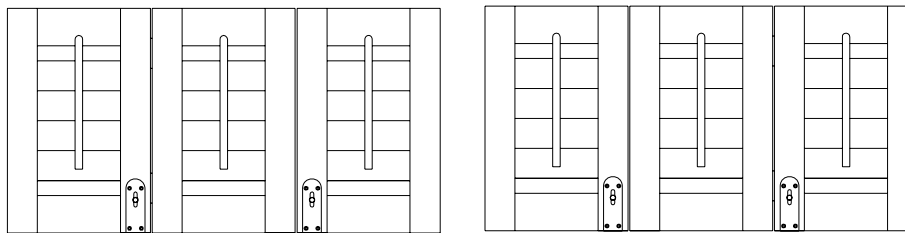

Panel Config: LLR

Panel Config: LRR

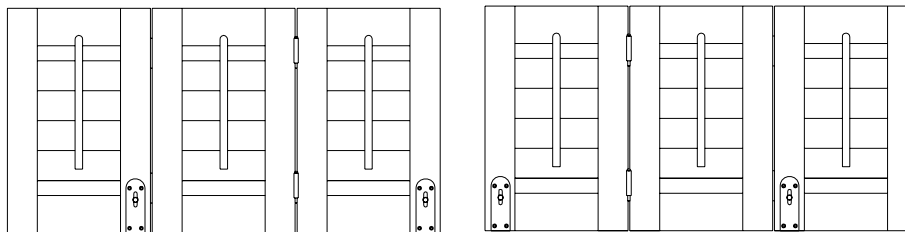

Panel Config: LLL

Panel Config: RRR

Sussex[®] NormanTeak[™] Shutters

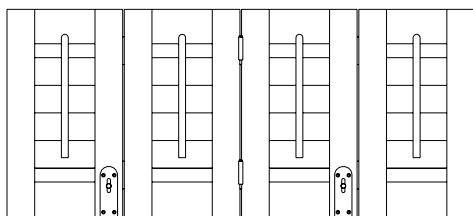

Panel Config: LLLL

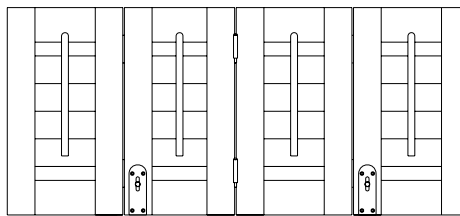

Panel Config: RRRR

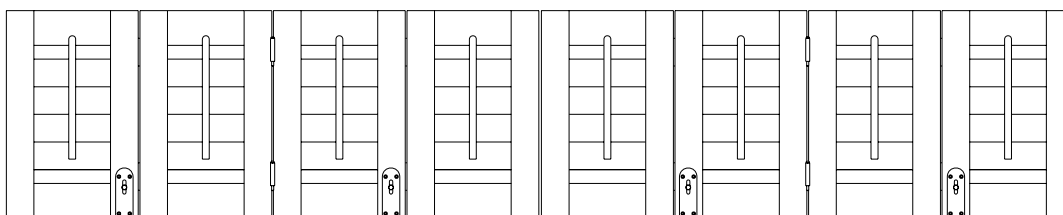

Panel Config: LLLRRRR

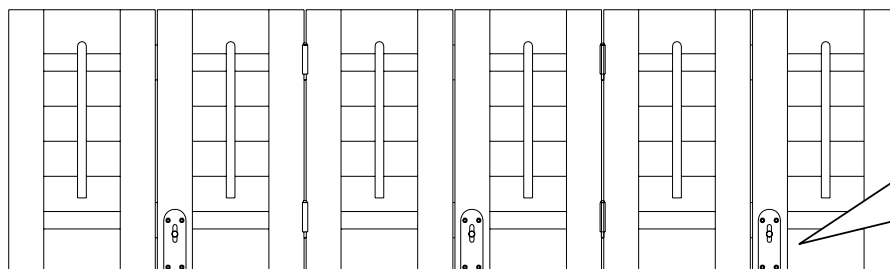

Panel Config: FFFFFF(R)

Default:
Floating panels
stacked to Right

The Panel Lock location for both track system shutters and regular shutters would be the same. The general principle is that the Panel Lock position will avoid the stile which will install the spring-loaded guide at bottom (same stile as the Wheel carrier).

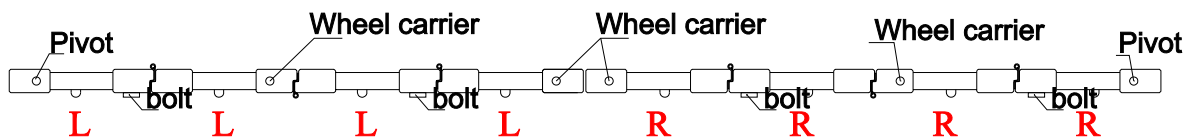

Ring Pull

for easy opening and closing (only available in stainless steel)

(Not available for 1.625" Stile)

Available Material: ALL



Position: For different panel configuration, please refer to the location of Panel Lock to show on which stile the pull will be fixed.

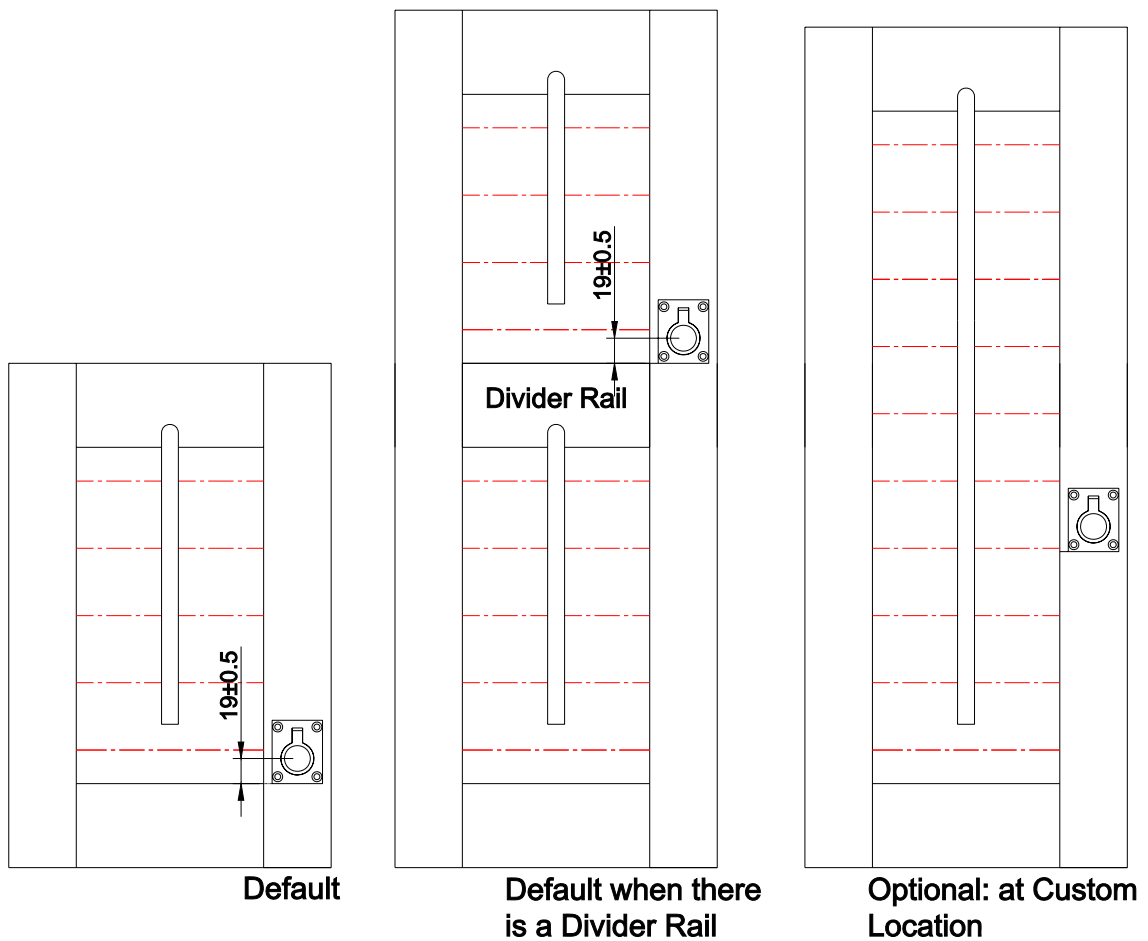

Position:

- A. Above Bottom Rail (Default)
- B. Above 1st Divider Rail (Default when there are Divider Rails)
- C. Custom Location

If both Panel Lock & ring pull are specified, the distance between them is 70mm, and the ring pull location is 171mm from the bottom of panel.

When there is no mid rail, ring pull will be just on the top of Panel Lock (70mm above Panel Lock) as default location; if there are mid rails, bottom of ring pull lines up with top of the 1st mid rail as default location.

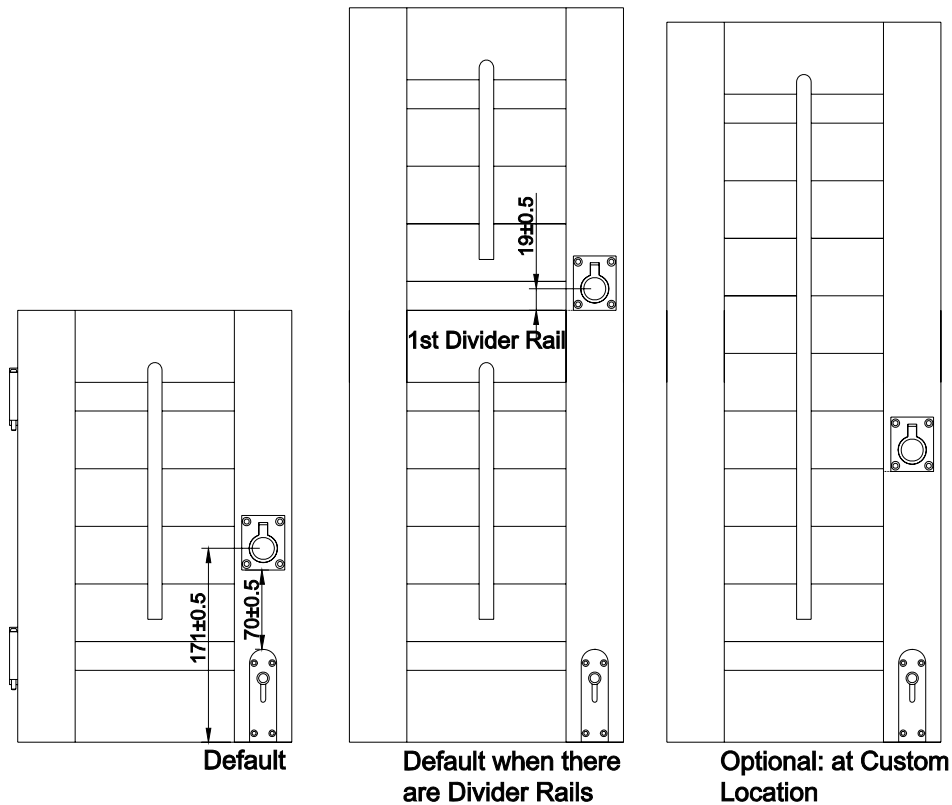

Position:

- A. 70mm Above Panel Lock (Default when both Ring Pull and Panel Lock are specified)
- B. Above 1st Divider Rail (Default when there are Divider Rails)
- C. Custom Location

Measurements:

- Window size:
 - Measure from the bottom of the window to the center of the ring pull.
- Max frame-to-frame:
 - Measure from the bottom of the frame to the center of the ring pull.

Side Magnet: Only available for Butt and Astragal stile



This option is applied to the meeting stiles of LR panels.

Application to following condition:

1. Double Hung shutter without horizontal T post:

The side magnet will be installed on the top of bot tom tier and bottom of top tier.

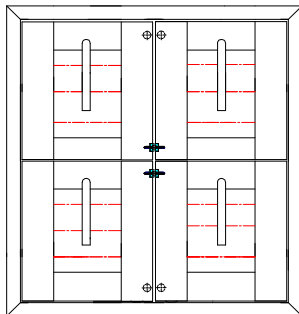

2. Café Shutter

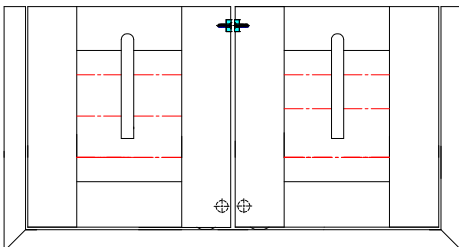

3. No frame or light block or L-shape striker plate on either top or bottom, or if larger than standard top or bottom gap is requested.

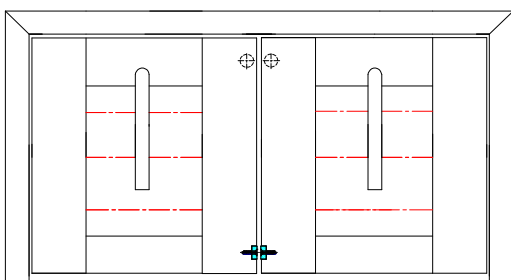

Track Shutters—Bifold & Multi-fold

Guidelines and Specs:

Description	Minimum	Maximum		
		1 ¼"	1 ⅞"	2 ½" / 3 ½" / 4 ½"
Single-Panel Width (Bifold Track)	6"	N/A	26"	26"
Single-Panel Width (Multifold track up to 4 panels)	6"	N/A	20"	20"
Single-Panel Height	10"	133"	133"	133"

Outside Mount

Max frame-to-frame width: window width + 3"

Max frame-to-frame height: window height + 4 ½"

Semi-Inside Mount

Max frame-to-frame width: window width - 1/8"

Max frame-to-frame height: window height + 1 3/8"

Inside Mount

Max frame-to-frame width: window width - 1/8"

Max frame-to-frame height: window height - 1/8"

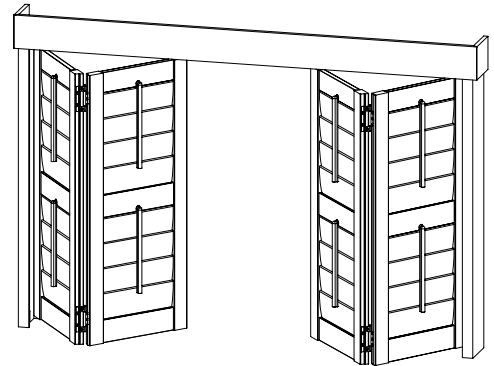

Panel Configuration:

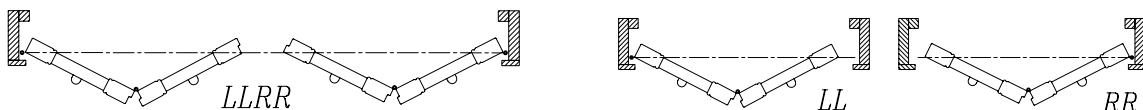

The max frame-to-frame height measurement should be from the floor to the top of the fascia, and the width measurement should be from the left side frame to the right side frame.

- Track is pre-installed on the header; standard 1 track only.
- Wheel carrier bracket and top pivot are pre-installed on the panel.
- Top pivot bracket, wheels and buffers will be installed in the track.
- Support L brackets on header are provided for OM boxout.

Track Shutters—Bifold & Multi-fold

Multi-Fold Track Shutters

Maximum single panel width for multi-fold is 20"

Panel Configuration : LLLL, RRRR, or LLLLRRRR

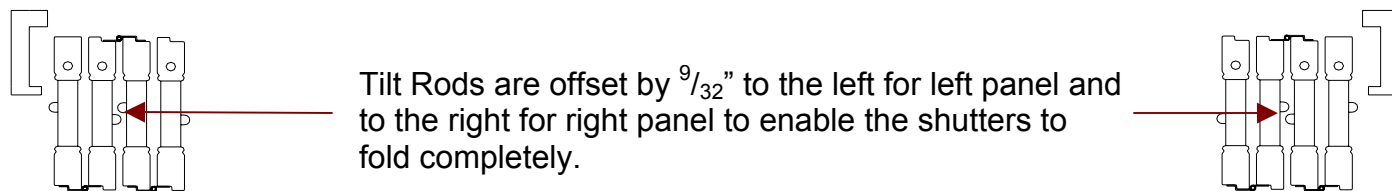
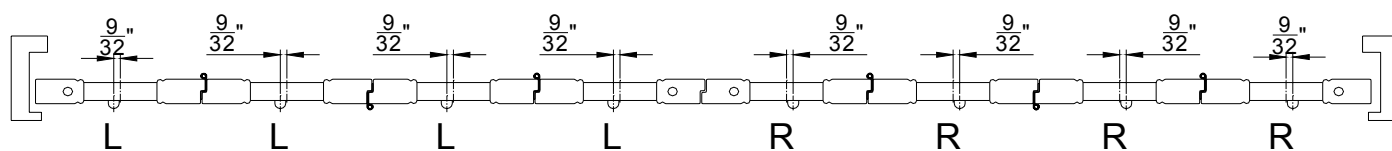

Track Shutters—Bifold & Multi-fold

Mounting Options

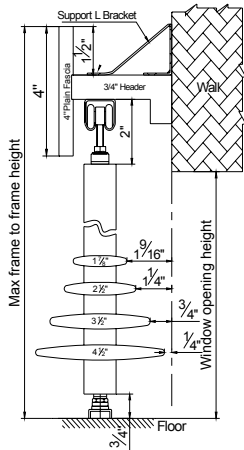

Plain Boxout

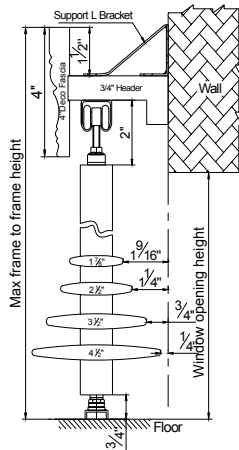

Deco Boxout

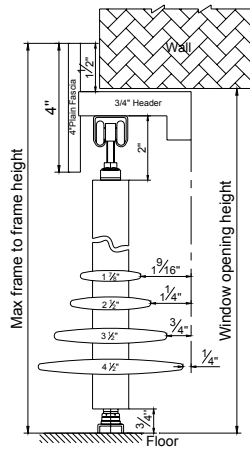

Plain Boxout

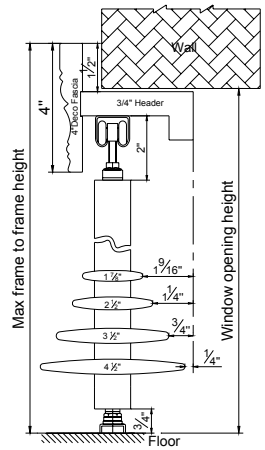

Deco Boxout

Outside Mount

Semi-Inside Mount

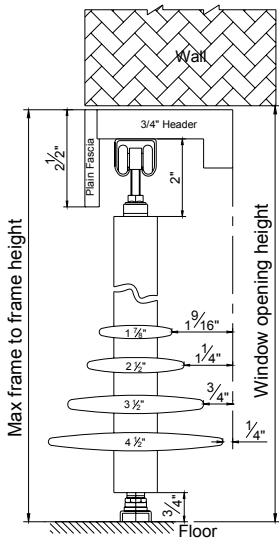

Plain Boxout

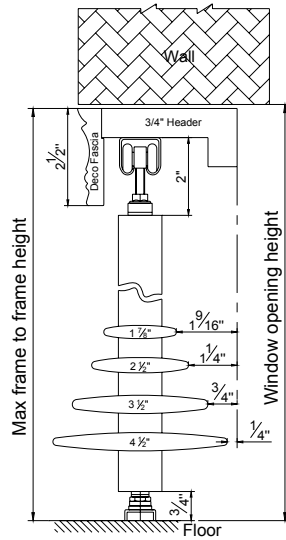

Deco Boxout

Inside Mount

Tracks Shutters-Bifold& Multi-fold Floating Panels

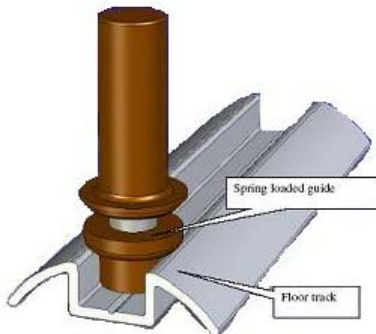
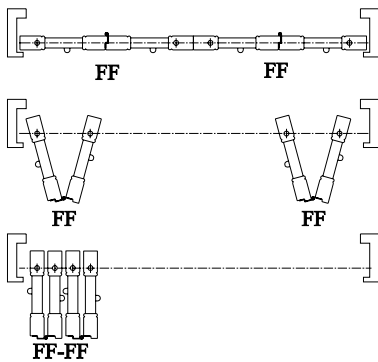
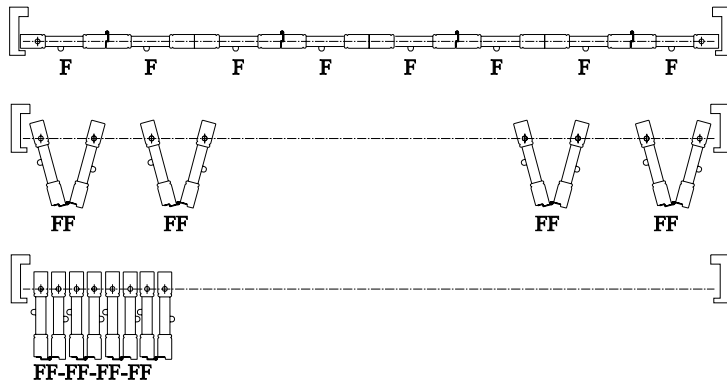

Outside Mount Bottom Track

- Two or four panels can be hinged together, fold and slide to either direction
- Application comes with wheel carrier, spring loaded guide and floor track
- Can be used on large window

* Surcharge applies. Please see Options and Surcharges page for details

Track Shutters—Bifold & Multi-fold

Track Shutters Framing Materials

Framing	Size			Pc(s)
L Shape Header (2 in 1) Header with Supporting Strip	Header	Supporting Strip		1 pc
	¾" x 3½"* (Default) ¾" x 4½"* or 5½"* (Optional) Custom * ≤ 8"	¾" x ¾"		
U Shape Side Frame (3 in 1) Side Frame with Supporting Strip & Side Fascia	Side Frame	Supporting Strip	Side Fascia	2 pcs
	¾" x 3 ⅞"* (Default) ¾" x 4½"* or 5 ⅞"* (Optional) Custom * ≤ 8"	¾" x ¾"	⅜" x 1¼ "	
Top Fascia (Plain/Deco)	4" (semi-inside and outside mount) 2½" (inside mount)			1 pc
Top Fascia Return	4" (semi-inside and outside mount) N/A (inside mount)			2 pcs

* L Shape Header and U Shape Side Frame are only available in 3½", 4½" and 5½". For other sizes, these framing materials come in separate pieces.

* If framing material in separate pieces is preferred for 3½", 4½" and 5½", please state clearly under the Special Instructions section of the order form.

* Surcharge applies. Please see Options and Surcharges page for details

Track Shutters—Bifold & Multi-fold

Hardware Box

Hardware Box	
Part	Qty
Wrench	2
Hinge Pin	According to number of hinges
Bottom Pivot Bracket	1 for panels folding in one direction
	2 for panels folding in both directions
1 ½ " screws for bottom pivot bracket	1 screw for each bottom pivot bracket
¾ " screws for bottom pivot bracket	3 screws for each bottom pivot bracket
Touch up paint	1
Support L Bracket (based on the length of header)	Header Length: Less than 90"- 2 brackets included 60"~120"- 3 brackets included 120"~150"- 4 brackets included For header length 150" and above, 1 bracket will be added for each additional 30".
2 ½ " screws for support L bracket	4 screw for each support L bracket
¾ " screws for support L bracket	5 screws for each 4", 5 ¼ ", 7" support L bracket 4 screws for each 3" support L bracket

Track Shutters—Bypass

Guidelines and Specs:

<u>Description</u>	<u>Minimum</u>	<u>Maximum</u>		
		1 ¼"	1 ⅞"	2 ½" / 3 ½" / 4 ½"
Single-Panel Width (Regular)	6"	16"	30"	36"
Single-Panel Width (for Bypass with Center Stile)	6"	N/A	30" ~ 50"	36" ~ 50"
Single-Panel Height	10"	133"	133"	133"

Outside Mount

Max frame-to-frame width: window width + 3"

Max frame-to-frame height: window height + 4 ½"

Semi-Inside Mount

Max frame-to-frame width: window width - 1/8"

Max frame-to-frame height: window height + 1 3/8"

Inside Mount

Max frame-to-frame width: window width - 1/8"

Max frame-to-frame height: window height - 1/8"

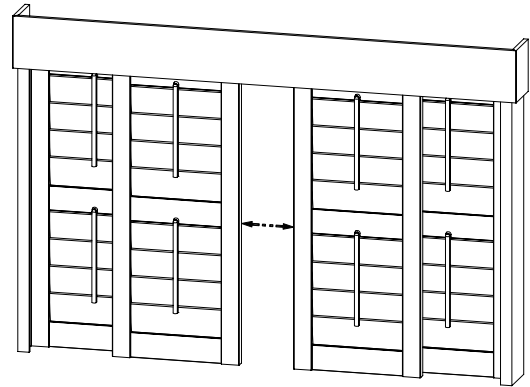

The max frame-to-frame height measurement should be from the floor to the top of the fascia, and the width measurement should be from the left side frame to the right side frame.

- Tracks are pre-installed on the header; standard 2 tracks only.
- Wheel carrier bracket and bottom guide are pre-installed on the panel.
- Wheels and buffers will be installed in the track.
- Support L brackets are provided for OM boxout.

Track Shutters—Bypass

Closed Bypass

Panels with center stile (optional)

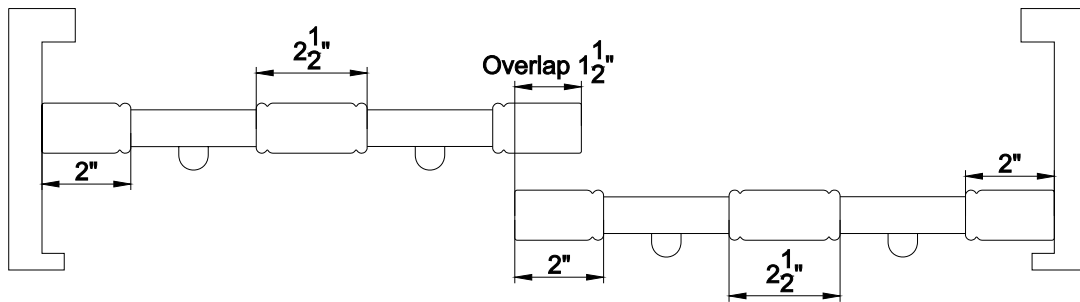

For shutters with 4 or more panels, please select "side open" or "center open" .

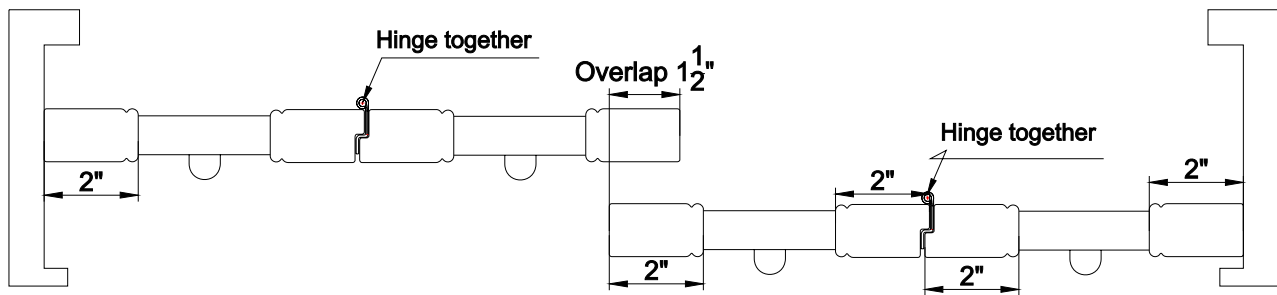

Side Open

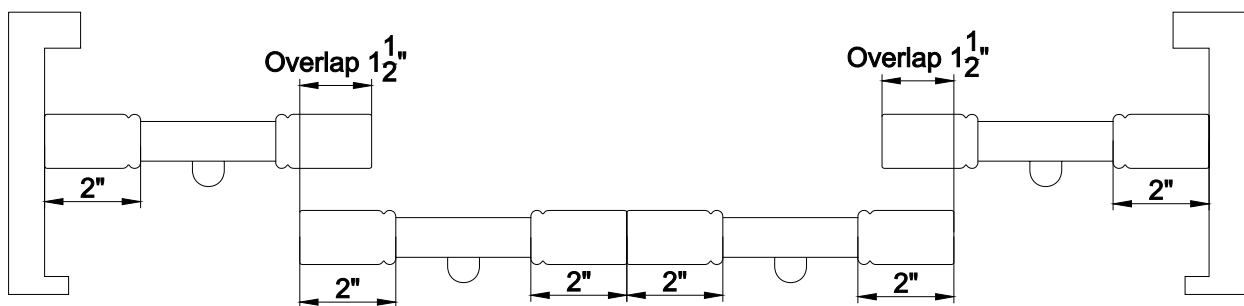

Center Open

Opened Bypass

Bypass panels with **Regular Tilt Rod**
—for U shape/ interlocking bottom guide*

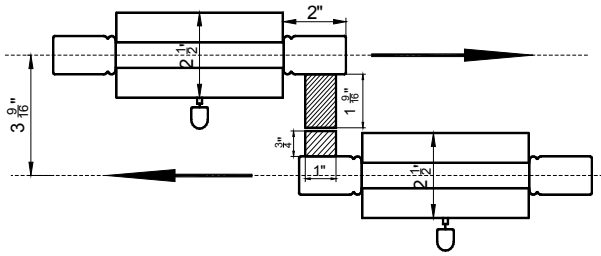

2 ½" Louver

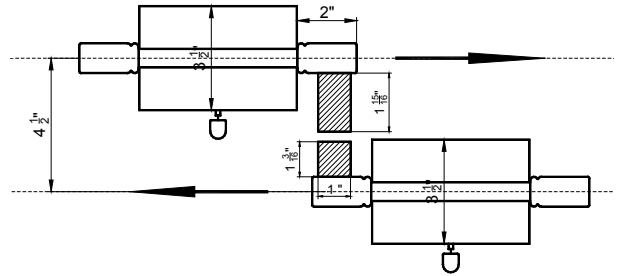

3 ½" Louver

Bypass panels with **InvisibleTilt™**
—for U shape bottom guide*

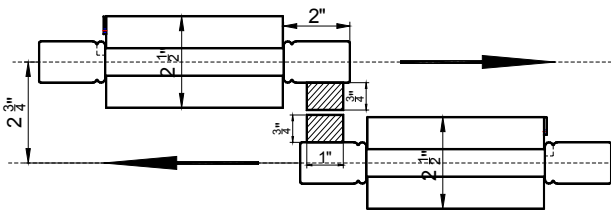

2 ½" Louver

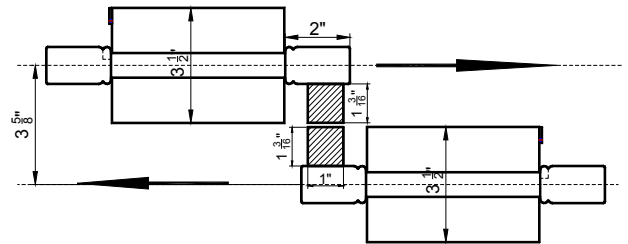

3 ½" Louver

Bypass panels with **InvisibleTilt™**
—for interlocking bottom guide*

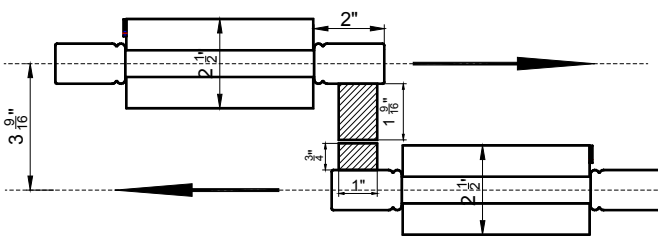

2 ½" Louver

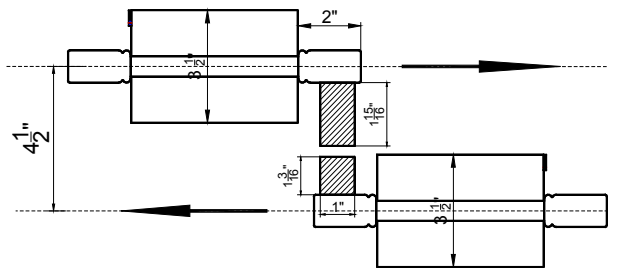

3 ½" Louver

* Surcharge applies. Please see Options and Surcharges page for details

Track Shutters—Bypass

Mounting Options (Closed Bypass)

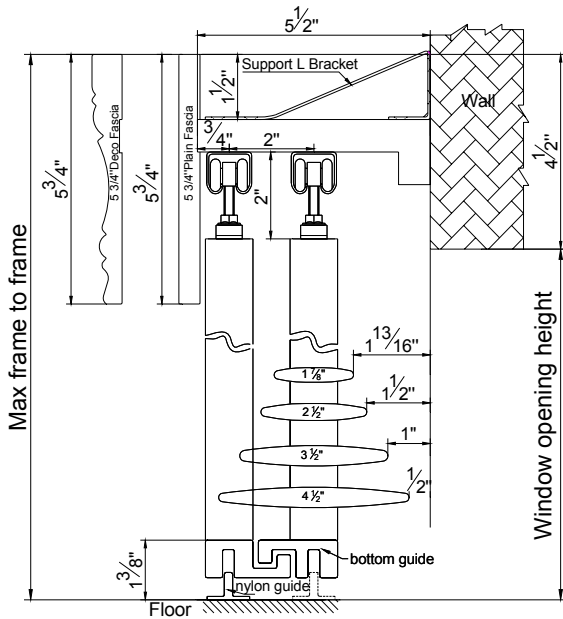

Outside Mount

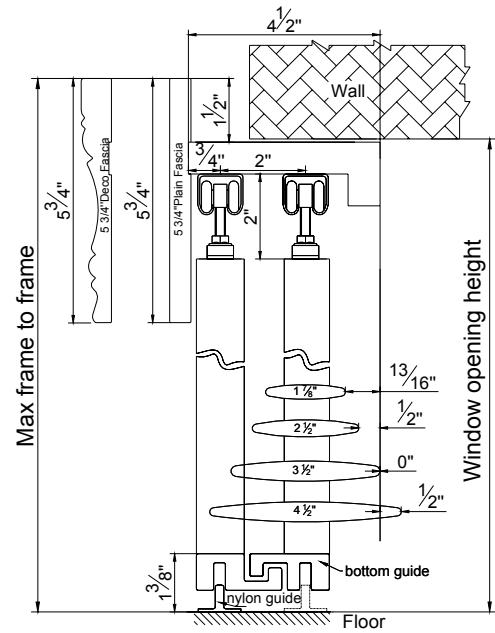

Semi-Inside Mount

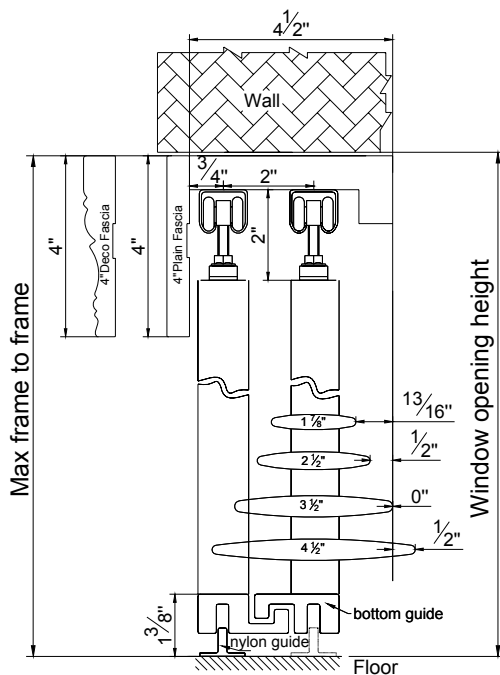

Inside Mount

Track Shutters—Bypass

Mounting Options (Closed Bypass with 3 Tracks)

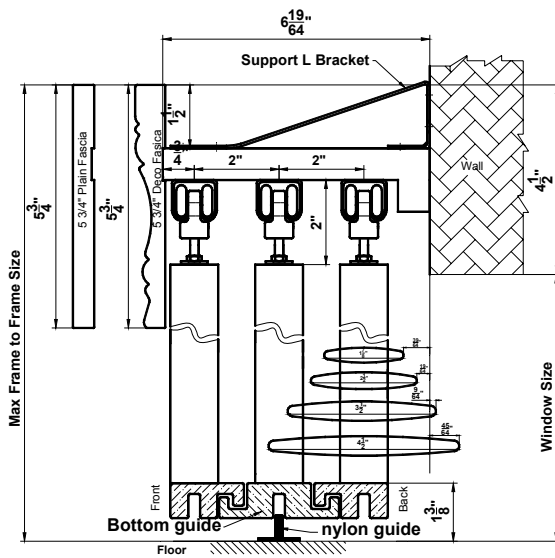

Outside Mount

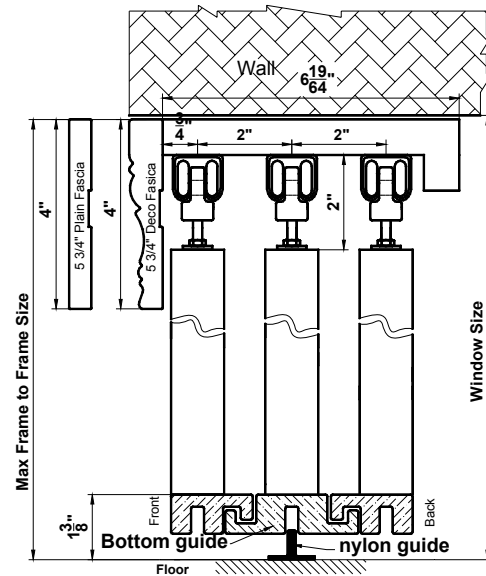

Inside Mount

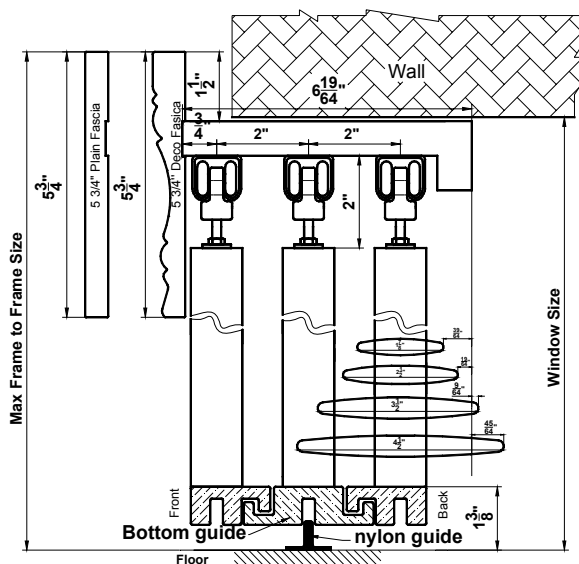

Semi-Inside Mount

* Surcharge applies. Please see Options and Surcharges page for details.

Track Shutters—Bypass

Mounting Options (Opened Bypass)*

- Only available in 2 1/2" and 3 1/2" louver sizes

2 1/2" Louver (Outside Mount)

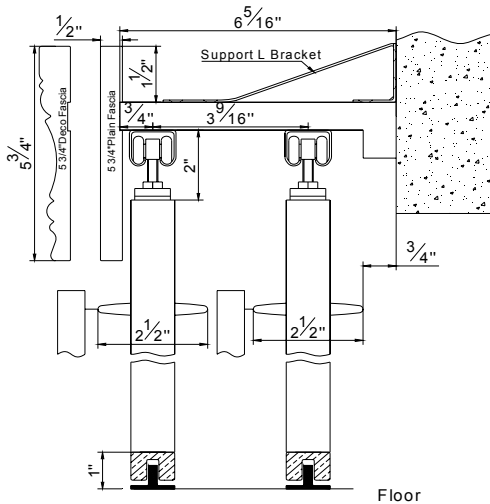

Default Bottom Guide

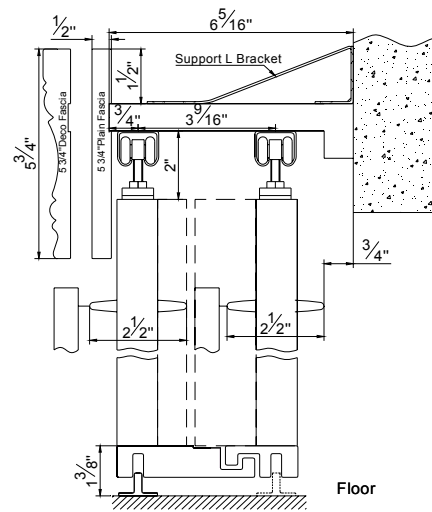

Optional Interlocking Bottom Guide *

2 1/2" Louver (Semi-Inside Mount)

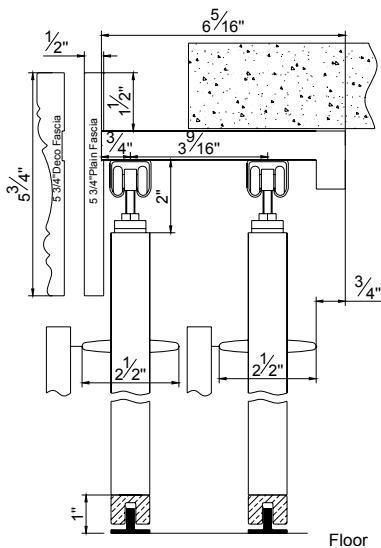

Default Bottom Guide

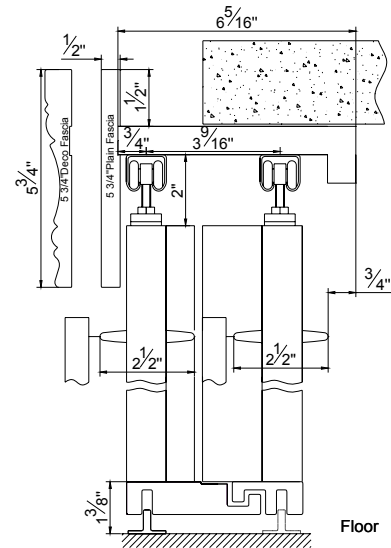

Optional Interlocking Bottom Guide *

* Surcharge applies. Please see Options and Surcharges page for details.

Track Shutters—Bypass

Mounting Options (Opened Bypass)*

- Only available in 2 ½" and 3 ½" louver sizes

2 ½" Louver (Inside Mount)

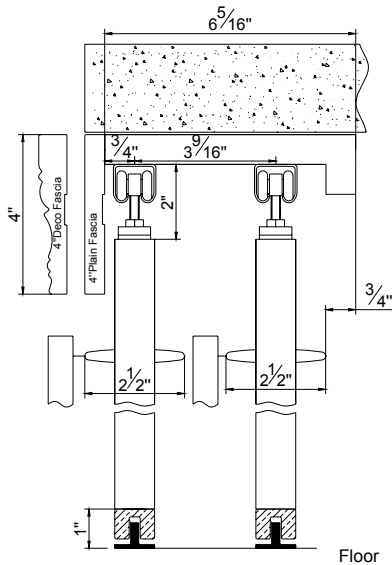

Default Bottom Guide

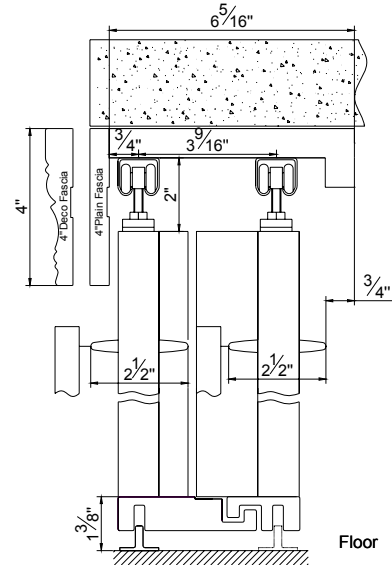

Optional Interlocking Bottom Guide*

* Surcharge applies. Please see Options and Surcharges page for details

Track Shutters—Bypass

Mounting Options (Opened Bypass)*

- Only available in 2 ½" and 3 ½" louver sizes

3 ½" Louver (Outside Mount)

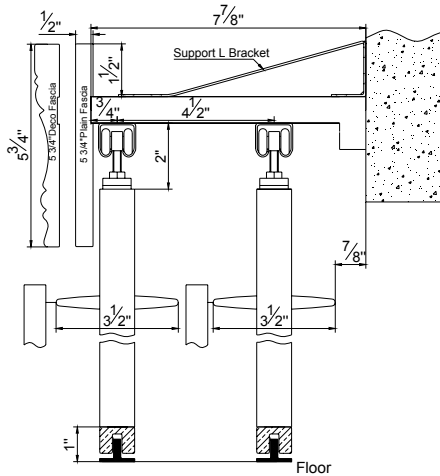

Default Bottom Guide

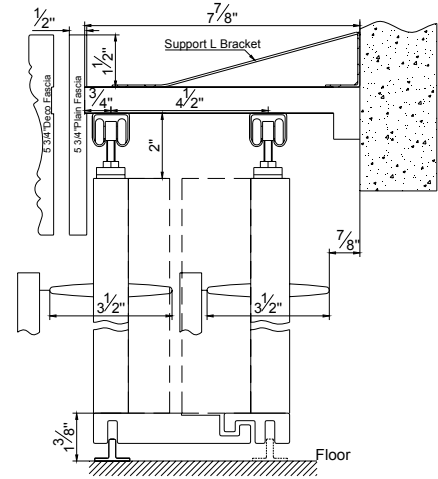

Optional Interlocking Bottom Guide*

3 ½" Louver (Semi-Inside Mount)

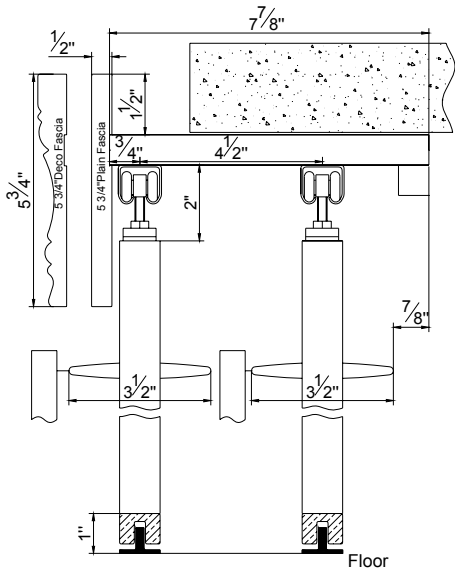

Default Bottom Guide

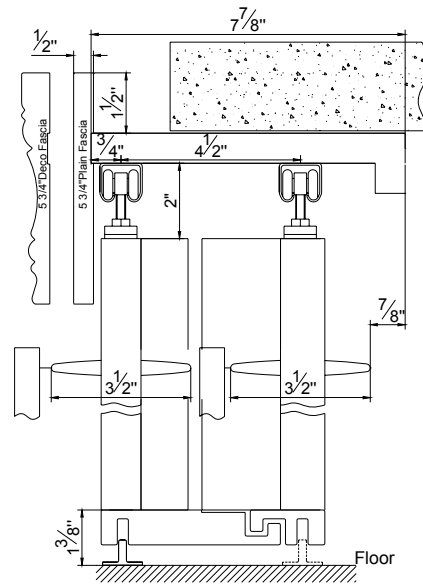

Optional Interlocking Bottom Guide*

* Surcharge applies. Please see Options and Surcharges page for details

Track Shutters—Bypass

Mounting Options (Opened Bypass)*

- Only available in 2 ½" and 3 ½" louver sizes

3 ½" Louver (Inside Mount)

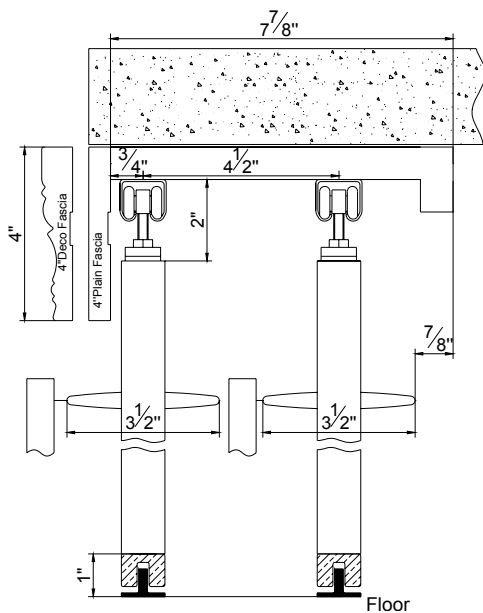

Default Bottom Guide

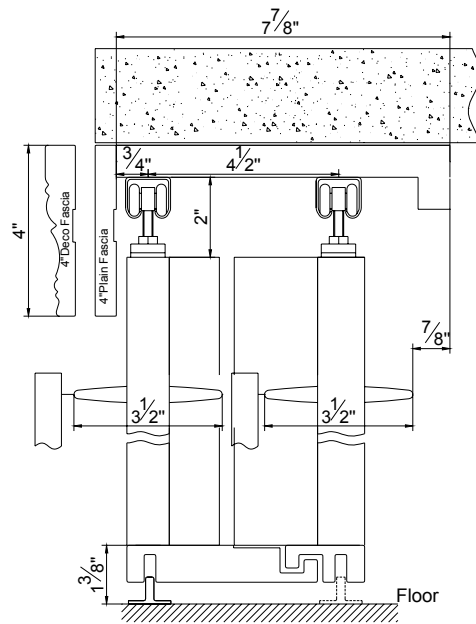

Optional Interlocking Bottom Guide*

* Surcharge applies. Please see Options and Surcharges page for details

Track Shutters—Bypass

Closed Bypass

- Available in all louver sizes



Opened Bypass*

- Available in 2 ½" and 3 ½" louver



Track Shutters—Bypass

Track Shutters Framing Materials

Framing	Size				Pc(s)
L Shape Header (2 in 1) Header with Supporting Strip	Header (Closed Bypass)	Header (Opened Bypass)	Supporting Strip		1 pc
	$\frac{3}{4}$ " x $5\frac{1}{2}$ "* (Default for Outside Mount; Optional for Semi-Inside and Inside Mount)	$\frac{3}{4}$ " x $6\frac{1}{4}$ "* ($2\frac{1}{2}$ " Louver)	$\frac{3}{4}$ " x $\frac{3}{4}$ "		
	$\frac{3}{4}$ " x $4\frac{1}{2}$ "* (Default for Semi-Inside and Inside Mount; Optional for Outside Mount)	$\frac{3}{4}$ " x $7\frac{13}{16}$ "* ($3\frac{1}{2}$ " Louver)			
	Custom * \leq 8"	Custom * \leq 8"			
U Shape Side Frame (3 in 1) Side Frame with Supporting Strip & Side Fascia	Side Frame (Closed Bypass)	Side Frame (Opened Bypass)	Supporting Strip	Side Fascia	2 pcs
	$\frac{3}{4}$ " x $5\frac{7}{8}$ "* (Default for Outside Mount; Optional for Semi-Inside and Inside Mount)	$\frac{3}{4}$ " x $6\frac{5}{8}$ "* ($2\frac{1}{2}$ " Louver)	$\frac{3}{4}$ " x $\frac{3}{4}$ "	$\frac{3}{8}$ " x $1\frac{1}{4}$ "	
	$\frac{3}{4}$ " x $4\frac{7}{8}$ "* (Default for Semi-Inside and Inside Mount; Optional for Outside Mount)	$\frac{3}{4}$ " x $8\frac{1}{4}$ "* ($3\frac{1}{2}$ " Louver)			
	Custom * \leq 8"	Custom * \leq 8"			
Top Fascia (Plain/Deco)	$5\frac{3}{4}$ " (Semi-inside and Outside Mount) $\frac{1}{2}$ " x 4" (Inside Mount)				1 pc
Top Fascia Return	$5\frac{3}{4}$ " (Semi-inside and Outside Mount) N/A (Inside Mount)				2 pcs

* L Shape Headers and U Shape Side Frames are only available in $3\frac{1}{2}$ ", $4\frac{1}{2}$ ", $5\frac{1}{2}$ ", $6\frac{1}{4}$ " and $7\frac{13}{16}$ ". For other sizes, these framing materials come in separate pieces.

* If framing material in separate pieces is preferred, please state clearly under the Special Instructions section of the order form.

Track Shutters—Bypass

Hardware Box

Hardware Box	
Part	Qty
Wrench	1
Nylon Guide	1 for each overlap (S+E shape bottom guide)
	1 for each bottom guide (U shape bottom guide)
¾ " screws for bottom pivot bracket	4 screw for each nylon guide
Touch up paint	1
Support L Bracket (based on the length of header)	Header Length: Less than 90"- 2 brackets included 60"~120"- 3 brackets included 120"~150"- 4 brackets included For header length 150" and above, 1 bracket will be added for each additional 30".
2 ½ " screws for support L bracket	4 screw for each support L bracket
¾ " screws for support L bracket	5 screws for each 4",5 ¼ ",7" support L bracket 4 screws for each 3" support L bracket

Special Options

Café Shutters*

- The top of the panel requires a special finish. Please indicate “café shutter” when placing orders.
- The shutter does not come with recessed magnet on top.

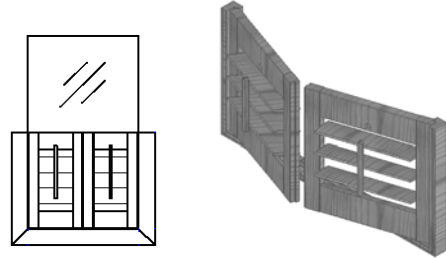

Double-Hung Shutters*

- For total number of panels, please include panels in both rows.
- For panel configuration, please provide panel fold for one row.
- The default location for the division point is the center unless specified otherwise.
- Horizontal T Post* can be added for increased structural integrity.

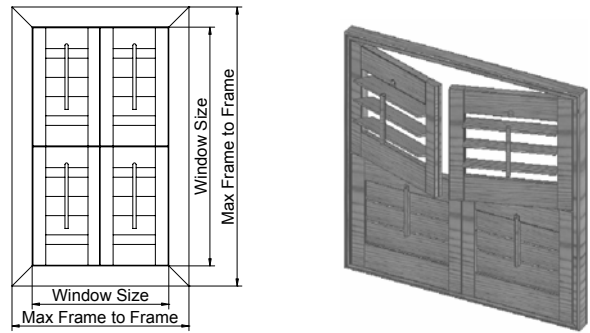

Fixed Louvers

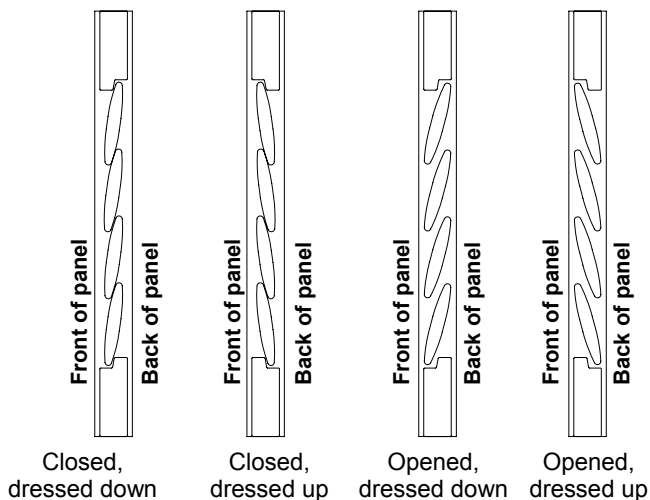
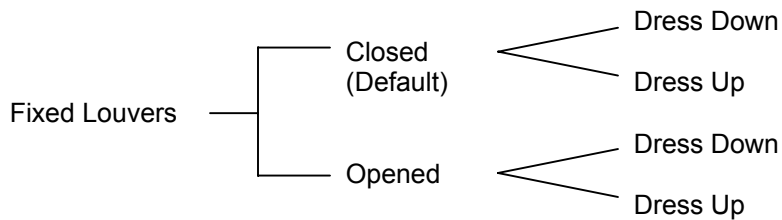

* Surcharge applies. Please see Options and Surcharges page for details.

Special Options (continued)

Raised Panel *

Available in

- Raised panel with louver combination .
- Raised panel only.

Specifications

- 12" ≤ raised panel section height ≤ 48".
- For 1¼" Colonial louver, divider rail is required for panel heights over 50".
- For other louver sizes, divider rail is required for panel heights over 78".
- The maximum panel height is 133".

Raised Panel Location(s)

- Top.
- Middle.
- Bottom.
- All (if panel height does not exceed 48").

Rails

- For a panel with raised panel section only, 3" is the standard size for top, bottom and divider rails.
- The minimum size for top and bottom rails is 3".
- If you are matching raised panels to standard shutter panels, the top rail of the standard shutter panel will match the top rail of the raised panel. Please specify clearly when placing order.

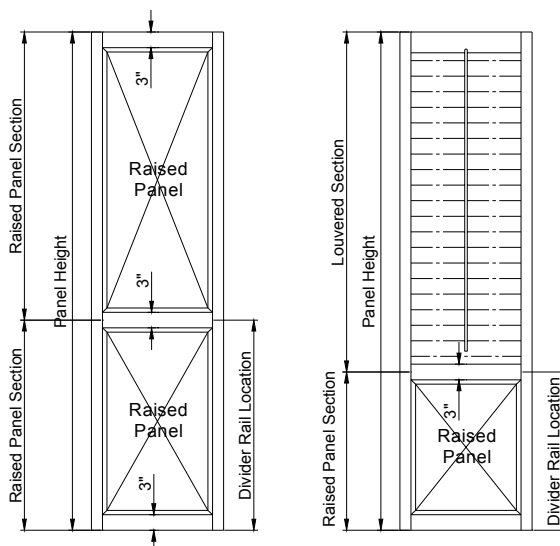

* Surcharge applies. Please see Options and Surcharges page for details.

Special Options (continued)

Hand-Carved Rail *

- Available for top and/or bottom rails.
- Please note that the proportion of the design is based on the height of the rail, not the width of the panel.



Vine



Wheat



Rosette



Star



Fish



Swan



Fleur de Lis

Special Options (continued)

Liberty Arch *

- The arch starts and ends 1" from the rail sides.
- The arch height is half of the top rail size (rounded up to $\frac{1}{8}$ " increment).
- The shape of the Arch is based on 3 points taken from the rail.
 - 1st point: 1" from the left stile
 - 2nd point: 1" from the right stile
 - 3rd point: Midpoint of the rail front

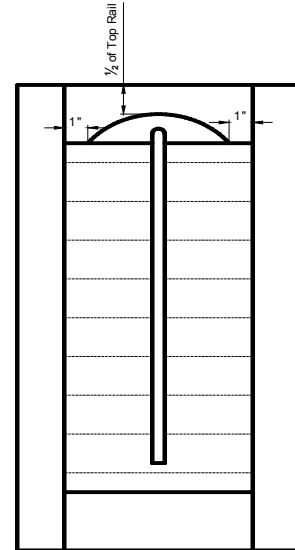

French Door Contour Collection*

- Flush and offset cutout options are available in both curved and square French door cutout.
 - ◊ Offset cutout is good option for French Door with molding around the glass.
- All French door cutouts are only available in L frame except Type E and F. The batten is placed behind the Type E/F panel to block light.
- For measurement details please refer to Form section.

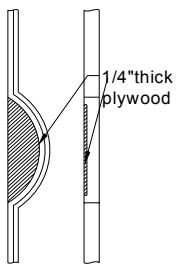

Type A

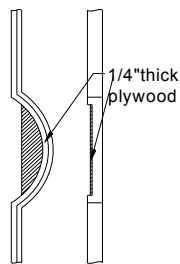

Type B

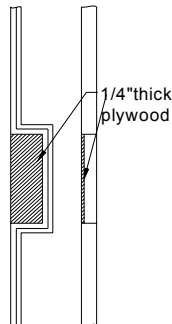

Type C

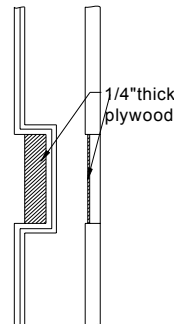

Type D



Type E

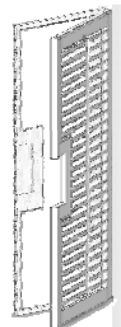

Type F

Special Options (continued)

Custom Colors *

Available in Sussex[®] shutters and Sussex[®]blinds.

Option (Color Code)	Sample Size	<u>Confirmation Process</u>
Custom Solid (C01)	At least 4" x 4" on a clean, flat surface such as wood or cardboard	All orders require customer's confirmation via actual swatch in the mail before production. Additional shipping and handling fee applies.
Custom Stain (C02)	At least 4" x 4" on a clean, flat surface such as wood or cardboard	All orders require customer's confirmation via digital photo OR actual swatch in the mail before production. Additional shipping and handling fee applies.

Note:

- 1) All custom colors will only be finished with the standard gloss used on all Norman products.
- 2) Please note that we will only be able to match the tone instead of the texture or finish of the sample your submit.
- 3) Only one dispute is allowed during the color confirmation process.
- 4) Customer may waive confirmation to shorten production lead time. Norman[®] will not be responsible for any color variation afterwards.

PerfectTilt[®] *

- Battery operated motor and remote control
 - No expensive and invasive hardwiring required
 - No unsightly cord and plug needed
- Sleek and easy to use wireless remote control
 - Pre-set angle remote buttons, plus minor adjustment, for maximum convenience
 - Complete light and privacy control

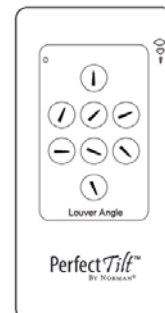

* Surcharge applies. Please see Options and Surcharges page for details.

New PerfectTilt RF

The new PerfectTilt RF has many exciting features & benefits.

- Norman[®] is the only national brand that offers motorization on shutters
- No need to plug-in, no cords, no hardwiring
- Tilt multiple panels in sync or individually
- Includes InvisibleTilt[™] system, a completely tilt-rod-free solution for a more streamlined view and improved energy efficiency
- Larger solar panels on solar modules absorb more energy than ever before
- Ergonomic remote includes 8 preset angles and can control unlimited number of shutters in range
- Utilizes RF signal, not traditional infrared: for precise reception, range up to 65 ft., no sensor holes, and no need to point remote directly at receiver
- Remote is equipped with a timer, allowing you to use your own computer from anywhere at any time with our proprietary web interface
- Whisper quiet, gear-driven system
- PerfectTilt[®] RF wires are concealed inside panel, completely hidden from view
- Extra battery packs can be installed as add-on for longer periods between recharges

Parts and Names:

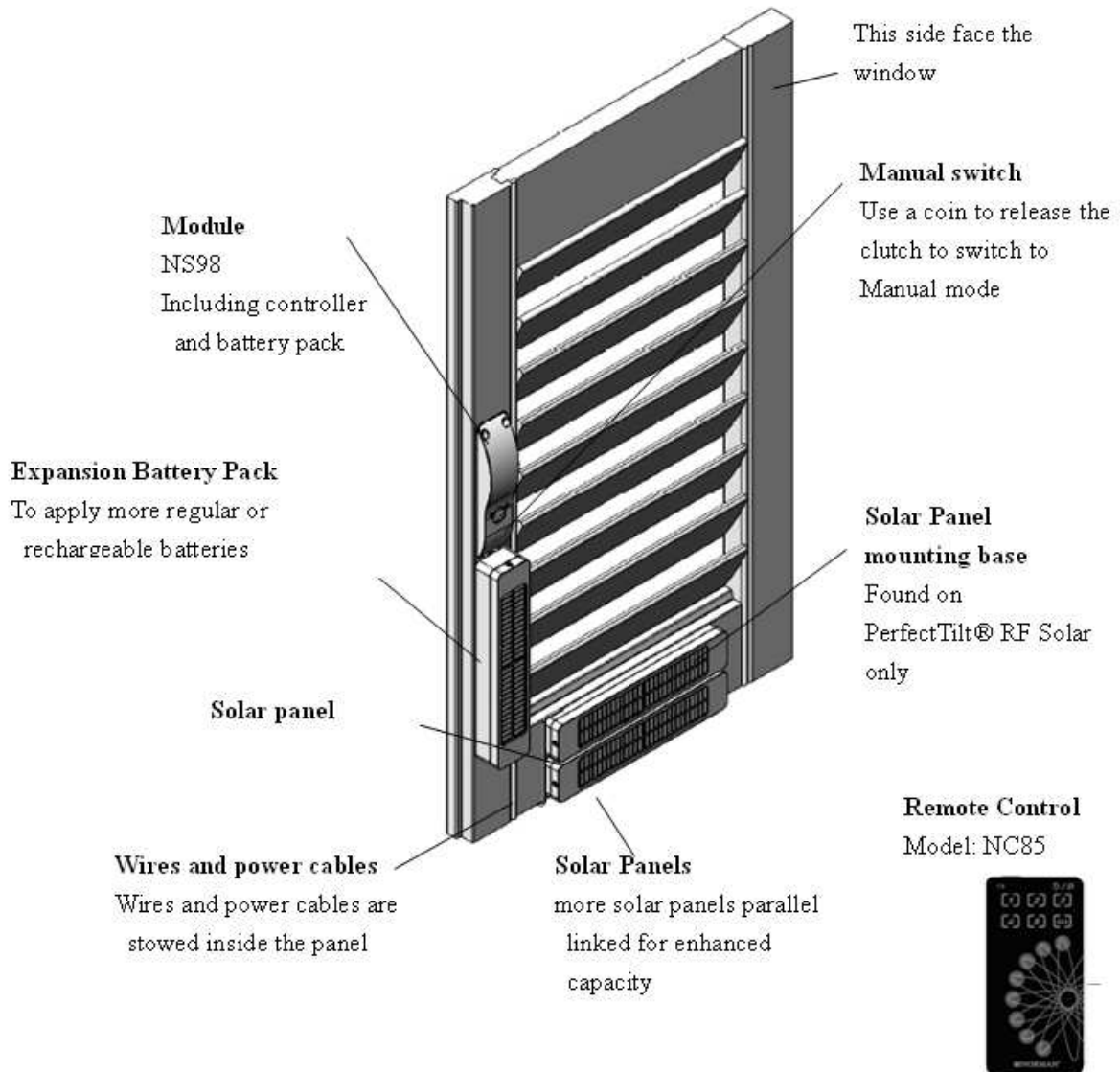

Specialties

Specialty Shutters*

Specialty shutters are made of premium solid wood, finished to match the beauty of all Norman shutters. Templates are required if it is an imperfect specialty. Delivery time is 8 weeks from the order confirmation date for all specialty shutters. Please refer to Specialties and Template Requirement sections for details.

All frames for specialty shutters will be made as solid frames (not with an insert). However, if there is a regular shutter below a specialty shutter and the frames for both shutters are separated by a divider strip, then the top frame will be made as a solid frame but the bottom frames will be made as regular frames with inserts. If the top frames and the side frames are not separated by a divider strip, both side frames and the bottom frames will be made as solid frames.

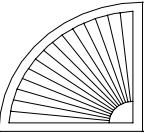
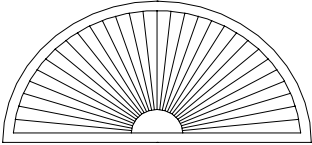
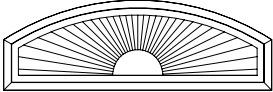
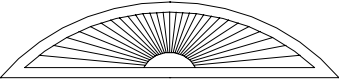
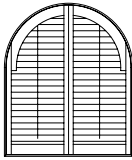
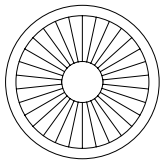
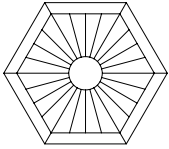
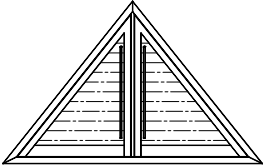
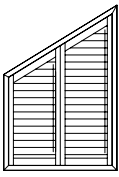
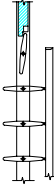
Arch Windows	Special Shapes
<div style="display: flex; justify-content: space-around;"> <div style="text-align: center;">  <p>Quarter Round Sunburst</p> </div> <div style="text-align: center;">  <p>Half Round Sunburst</p> </div> </div> <div style="display: flex; justify-content: space-around; margin-top: 20px;"> <div style="text-align: center;">  <p>Elongated Eyebrow Sunburst</p> </div> <div style="text-align: center;">  <p>Eyebrow Sunburst</p> </div> </div>	<div style="display: flex; justify-content: space-around;"> <div style="text-align: center;">  <p>Louvered Arch w/ Center Tilt Rod</p> </div> <div style="text-align: center;">  <p>Circle Sunburst</p> </div> </div> <div style="display: flex; justify-content: space-around; margin-top: 20px;"> <div style="text-align: center;">  <p>Hexagon Sunburst</p> </div> <div style="text-align: center;">  <p>Triangle</p> </div> </div>
Angle Top	
<div style="display: flex; justify-content: space-around; align-items: center;"> <div style="text-align: center;">  <p>Angle Top</p> </div> <div style="text-align: center;">  <p>*Top louver of angle top might be fixed as shown above</p> </div> </div>	

* Surcharge applies. Please see Options and Surcharges page for details.

Pricing

1) By Max Frame-to-Frame Measurement:						
Regular Shutter						
Inside and Outside Mount	Width	x	Height	/ 144	x	\$/sq ft
Track Shutter**						
Inside	Width	x	Height	/ 144	x	\$/sq ft
Semi-Inside and Outside Mount	Width	x	(Height-1½")	/ 144	x	\$/sq ft
2) By Net Panel Measurement:						
	Width	x	Height	/ 144	x	\$/sq ft
3) By Window Size:						
2" Camber Deco Frame 2" Classic Deco Frame	4-sided	(Width+4")	x	(Height+4")	/ 144	x \$/sq ft
	3-sided with Deco Sill Frame	(Width+4")	x	(Height+5")	/ 144	x \$/sq ft
	3-sided with Designer Sill Cap	(Width+4")	x	(Height+8")	/ 144	x \$/sq ft
	3-sided with Sill Plate	(Width+4")	x	(Height+4")	/ 144	x \$/sq ft
	3-sided	(Width+4")	x	(Height+2")	/ 144	x \$/sq ft
	2-sided with Deco Sill Frame	(Width+4")	x	(Height+3")	/ 144	x \$/sq ft
	2-sided with Designer Sill Cap	(Width+4")	x	(Height+6")	/ 144	x \$/sq ft
	2 sided with Sill Plate	(Width+4")	x	(Height+2")	/ 144	x \$/sq ft
	2-sided	(Width+4")	x	(Height)	/ 144	x \$/sq ft
3" Ridge Deco Frame	4-sided	(Width+6")	x	(Height+6")	/ 144	x \$/sq ft
	3-sided with Deco Sill Frame	(Width+6")	x	(Height+6")	/ 144	x \$/sq ft
	3-sided with Designer Sill Cap	(Width+6")	x	(Height+9")	/ 144	x \$/sq ft
	3-sided with Sill Plate	(Width+6")	x	(Height+6")	/ 144	x \$/sq ft
	3-sided	(Width+6")	x	(Height+3")	/ 144	x \$/sq ft
	2-sided with Deco Sill Frame	(Width+6")	x	(Height+3")	/ 144	x \$/sq ft
	2-sided with Designer Sill Cap	(Width+6")	x	(Height+6")	/ 144	x \$/sq ft
	2-sided with Sill Plate	(Width+6")	x	(Height+3")	/ 144	x \$/sq ft
	2-sided	(Width+6")	x	(Height)	/ 144	x \$/sq ft
3" Crown Z Frame	4-sided	(Width+4 ½")	x	(Height+4½")	/ 144	x \$/sq ft
	3-sided with Deco Sill Frame	(Width+4 ½")	x	(Height+5¼")	/ 144	x \$/sq ft
	3-sided with Designer Sill Cap	(Width+4 ½")	x	(Height+8¼")	/ 144	x \$/sq ft
	3-sided with Sill Plate	(Width+4 ½")	x	(Height+4½")	/ 144	x \$/sq ft
	3-sided	(Width+4 ½")	x	(Height+2¼")	/ 144	x \$/sq ft
	2-sided with Deco Sill Frame	(Width+4 ½")	x	(Height+3")	/ 144	x \$/sq ft
	2-sided with Designer Sill Cap	(Width+4 ½")	x	(Height+6")	/ 144	x \$/sq ft
	2-sided with Sill Plate	(Width+4 ½")	x	(Height+2¼")	/ 144	x \$/sq ft
	2-sided	(Width+4 ½")	x	(Height)	/ 144	x \$/sq ft

Pricing

2" Bel Air Z Frame	4-sided	(Width+2 ½")	x	(Height+2½")	/ 144	x	\$/sq ft
	3-sided with Deco Sill Frame	(Width+2 ½")	x	(Height+4¼")	/ 144	x	\$/sq ft
	3-sided with Designer Sill Cap	(Width+2 ½")	x	(Height+7¼")	/ 144	x	\$/sq ft
	3-sided with Sill Plate	(Width+2 ½")	x	(Height+2½")	/ 144	x	\$/sq ft
	3-sided	(Width+2 ½")	x	(Height+1¼")	/ 144	x	\$/sq ft
	2-sided with Deco Sill Frame	(Width+2 ½")	x	(Height+3")	/ 144	x	\$/sq ft
	2-sided with Designer Sill Cap	(Width+2 ½")	x	(Height+6")	/ 144	x	\$/sq ft
	2-sided with Sill Plate	(Width+2 ½")	x	(Height+1¼")	/ 144	x	\$/sq ft
	2-sided	(Width+2 ½")	x	(Height)	/ 144	x	\$/sq ft
1 ½ " Bullnose Z Frame/ 1 ¼ " Beaded Z Frame/ Bullnose Tilt Out Z Frame	4-sided	(Width+2")	x	(Height+2")	/ 144	x	\$/sq ft
	3-sided with Deco Sill Frame	(Width+2")	x	(Height+4")	/ 144	x	\$/sq ft
	3-sided with Designer Sill Cap	(Width+2")	x	(Height+7")	/ 144	x	\$/sq ft
	3-sided with Sill Plate (N/A w/ Tilt out Z)	(Width+2")	x	(Height+2")	/ 144	x	\$/sq ft
	3-sided	(Width+2")	x	(Height+1")	/ 144	x	\$/sq ft
	2-sided with Deco Sill Frame	(Width+2")	x	(Height+3")	/ 144	x	\$/sq ft
	2-sided with Designer Sill Cap	(Width+2")	x	(Height+6")	/ 144	x	\$/sq ft
	2-sided with Sill Plate (N/A w/ Tilt out Z)	(Width+2")	x	(Height+1")	/ 144	x	\$/sq ft
	2-sided	(Width+2")	x	(Height)	/ 144	x	\$/sq ft
Vintage Hang Strip	Inside	Width	x	Height	/ 144	x	\$/sq ft
	Outside 4-sided	(Width+3")	x	(Height+3")	/ 144	x	\$/sq ft
	Outside 3-sided with Deco Sill Frame	(Width+3")	x	(Height+4½")	/ 144	x	\$/sq ft
	Outside 3-sided with Designer Sill Cap	(Width+3")	x	(Height+7½")	/ 144	x	\$/sq ft
	Outside 3-sided	(Width+3")	x	(Height+1½")	/ 144	x	\$/sq ft
	Outside 2-sided with Deco Sill Frame	(Width+3")	x	(Height+3")	/ 144	x	\$/sq ft
	Outside 2-sided with Designer Sill Cap	(Width+3")	x	(Height+6")	/ 144	x	\$/sq ft
	Outside 2-sided	(Width+3")	x	(Height)	/ 144	x	\$/sq ft
Vintage L Frame/ Beaded L Frame/ Bullnose L Frame/	Inside (max frame to frame measurement only)	Width	x	Height	/ 144	x	\$/sq ft
	Outside 4-sided	(Width+3")	x	(Height+3")	/ 144	x	\$/sq ft
	Outside 3-sided with Deco Sill Frame	(Width+3")	x	(Height+4½")	/ 144	x	\$/sq ft
	Outside 3-sided with Designer Sill Cap	(Width+3")	x	(Height+7½")	/ 144	x	\$/sq ft
	Outside 3-sided	(Width+3")	x	(Height+1½")	/ 144	x	\$/sq ft
	Outside 2-sided with Deco Sill Frame	(Width+3")	x	(Height+3")	/ 144	x	\$/sq ft
	Outside 2-sided with Designer Sill Cap	(Width+3")	x	(Height+6")	/ 144	x	\$/sq ft
	Outside 2-sided	(Width+3")	x	(Height)	/ 144	x	\$/sq ft
Track Shutter**							
Inside and Semi-Inside Mount		Width	x	Height	/144	x	\$/sq ft
Outside Mount		(Width+3")	x	(Height+3")	/144	x	\$/sq ft

Options and Surcharges

Option	Surcharge	Remark
1¼" Louver	10%	
1⅝" Louver	10%	
Beaded L Frame with ¼" Thick Light Block	No surcharge	
L Frame with ½" & 1" Buildout	5%	
Deco Frame with ½", 1" & 1½" Extension	5%	
Custom extension	10%	Up to 2" for L Frames, Deco Frames and Hang Strip (OM) Up to 1" for Z frames (n/a for Tilt Out Z frame)
T Post	No surcharge	
T Post Extension	5%	Up to 2"
90 degree Corner Post & 135 degree Bay Post	No surcharge	
Custom Notch Out	10%	
Double Hung / Horizontal 1¾" T Post	10%	
Custom Angle/Depth Bay Post	5%	Up to 2" for custom depth
Extra Light Block	Charge per linear ft	Please contact your Customer Account Specialist for details
Scribe Trim	Charge per linear ft	Please contact your Customer Account Specialist for details
Center Tilt Rod	No surcharge	
Offset Tilt Rod	5%	
InvisibleTilt [™]	10%	Panels over 48" will have a split InvisibleTilt tilt rod. Not available in 1⅝" louvers.
Café Shutters	30%	Surcharge applies when the frame exceeds 5" beyond the top of the panel.
Fixed Louvers	No surcharge	Please indicate fixed position: up/down and open/close
Specialty Shapes	See specialty surcharge	Please contact your Customer Account Specialist for details
Track	See specialty surcharge	Please contact your Customer Account Specialist for details
Plain Boxout (Standard size)	30%	
Deco Boxout (Standard size)	35%	
Plain Boxout (Custom size)	40%	
Deco Boxout (Custom size)	45%	
Interlocking Bottom Guide (Opened Bypass)	5%	
Stainless Steel Hinges	5%	
InvisibleHinge [™]	10%	

Appendix

Color Coordination Chart (Solid)

Code	Sussex Solid	Hinge
001	Pure White	White
003	Silk White	White
004	Bright White	White
006	Pearl	Pearl
007	Ivory Lace	Pearl
008	Marshmallow	Pearl
009	Creamy	Bisque
011	Cameo	Bisque
012	Crisp Linen	Bisque
013	Bisque	Bisque
016	Butter	Bisque
019	String	Bisque
030	Moondust	Nickel Plated
032	Sea Mist	Nickel Plated
046	Ice	White
048	Chai	Nickel Plated
049	Stone Grey	Nickel Plated
051	Brown Grey	Nickel Plated
053	Clay	Nickel Plated
063	Decorators White	White
836	Classic Black	Black

Color Coordination Chart (Stain)



Code	Sussex Stain	Hinge Color
108	Rustic Gray	Antique Brass
110	Limed White	White
114	Taupe	Nickel Plated
200	Natural	Antique Brass
202	Golden Oak	Antique Brass
204	Oak Mantel	Antique Brass
205	Goldenrod	Antique Brass
206	Pecan	Antique Brass
211	Cherry	Antique Brass
212	Dark Teak	Antique Brass
214	Cocoa	Antique Brass
215	Cordovan	Antique Brass
219	Mahogany	Antique Brass
220	New Ebony	Antique Brass
221	Black Walnut	Antique Brass
227	Red Oak	Antique Brass
229	Rich Walnut	Antique Brass
230	Old Teak	Antique Brass
231	Spring Rose	Antique Brass
232	Red Mahogany	Antique Brass
233	Dark Mahogany	Antique Brass
237	Wenge	Antique Brass
242	Auburn	Antique Brass
247	Bark	Antique Brass
248	Pretzel	Antique Brass
249	Acorn	Antique Brass
250	Sumatra	Antique Brass
251	Raisin	Antique Brass
252	Toffee	Antique Brass

Louver Depth Clearance

Standard Tilt Rod

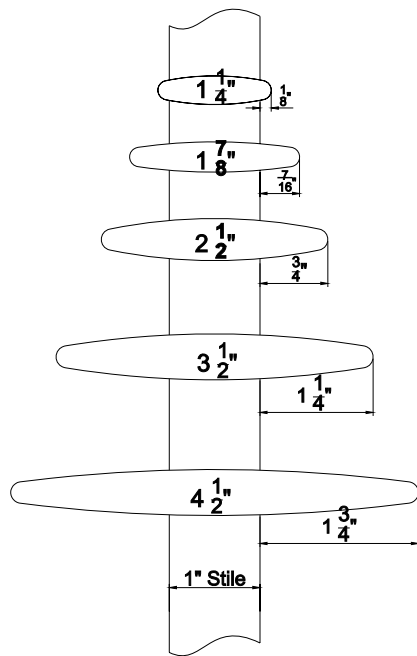

Offset Tilt Rod

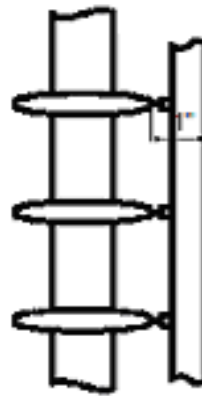

Louver Depth Clearance for Specific Frames

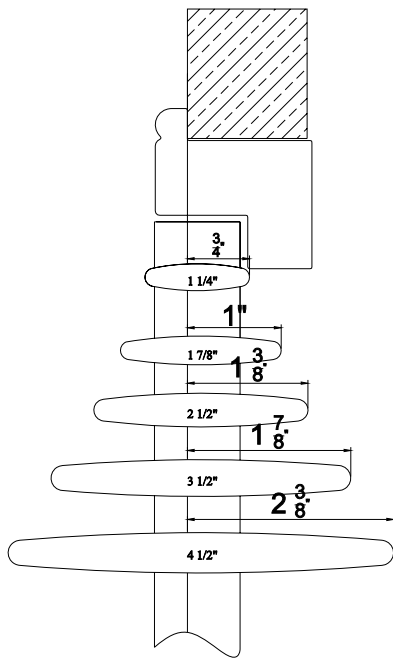

1 1/4" Beaded Z Frame

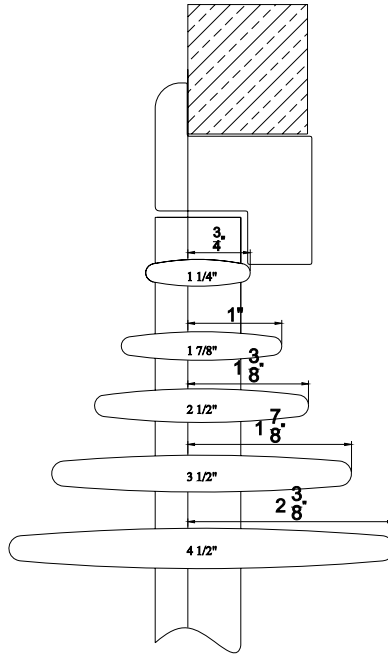

1 1/2" Bullnose Z Frame

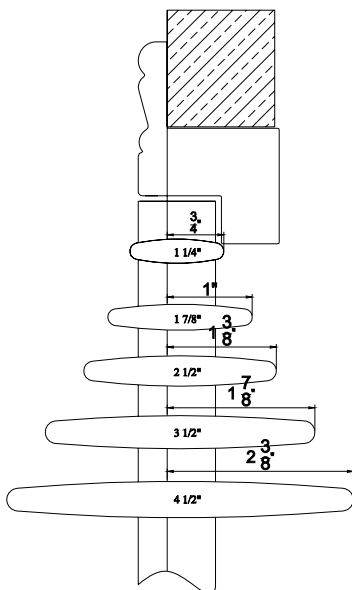

2" Bel Air Z Frame

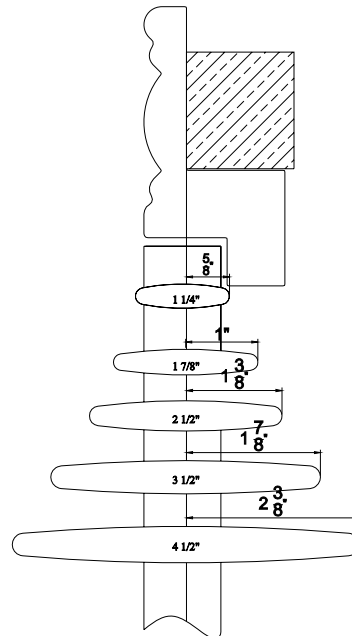

3" Crown Z Frame

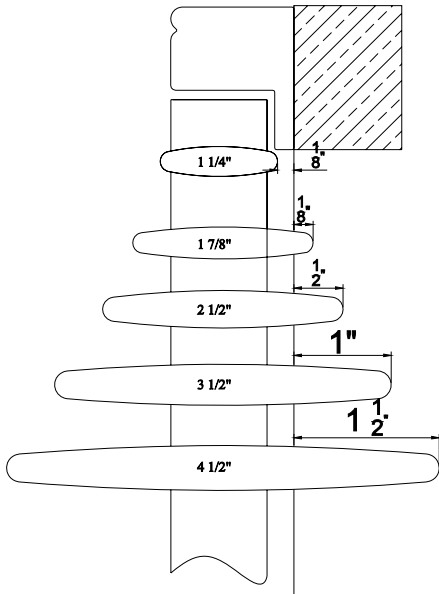

**Beaded L Frame W/1/4"
Light Block**

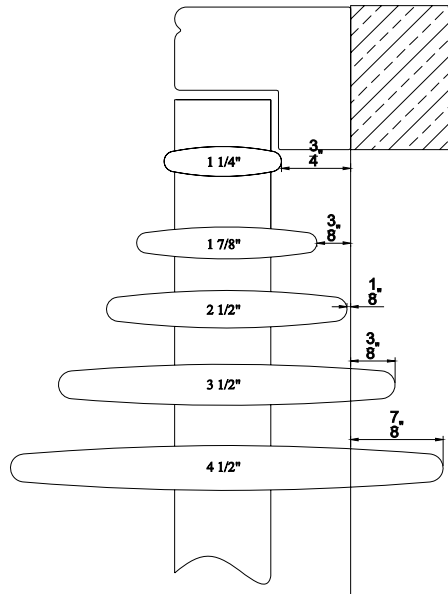

Beaded L Frame

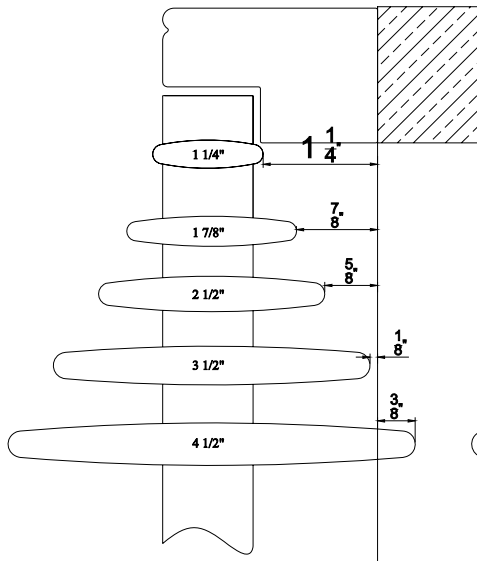

Beaded L W/1/2" Buildout

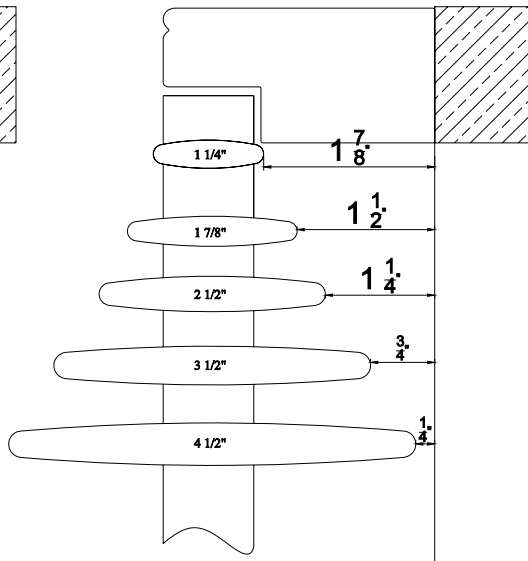

Beaded L W/1" Buildout

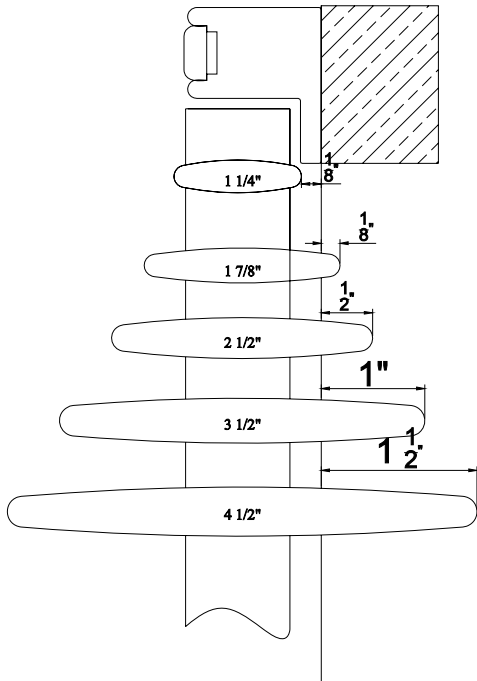

**Vintage L Frame W/1/4"
Light Block**

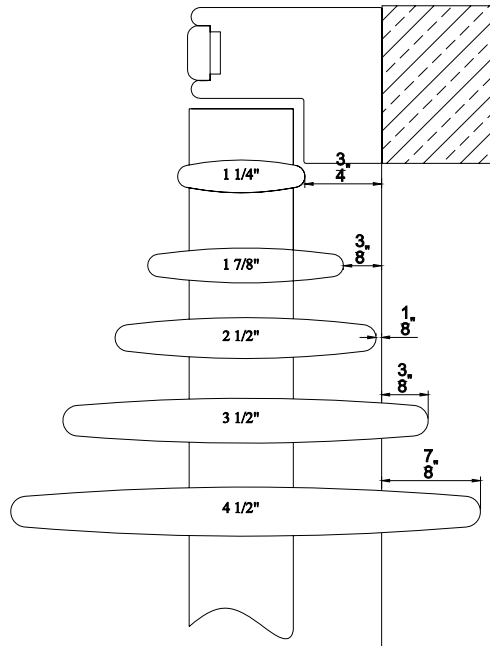

Vintage L Frame

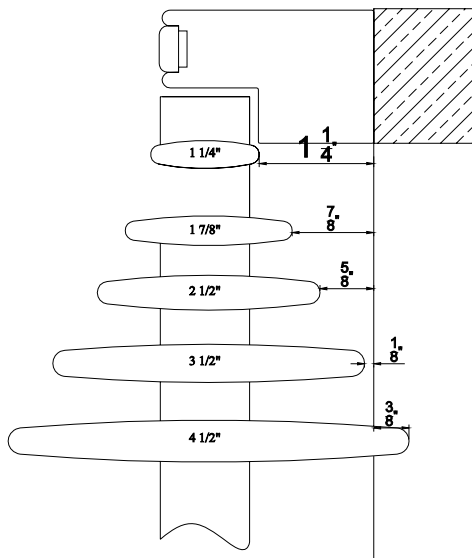

**Vintage L W/1/2"
Buildout**

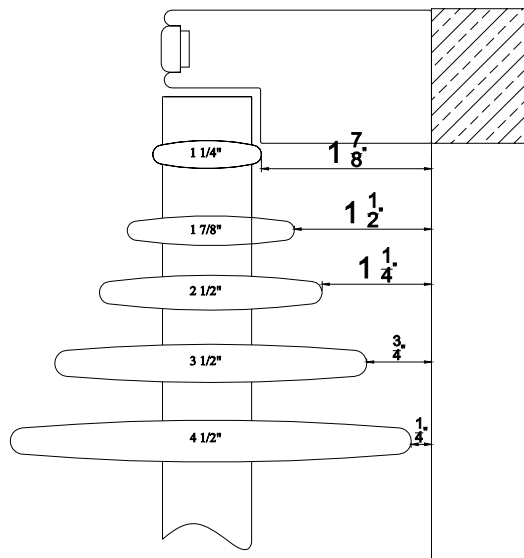

Vintage L W/1" Buildout

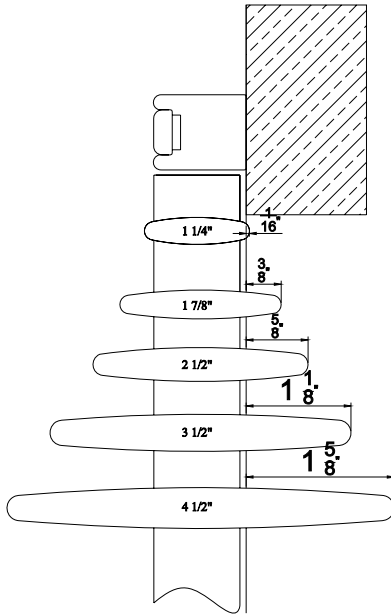

Hang Strip (Beside the panel)

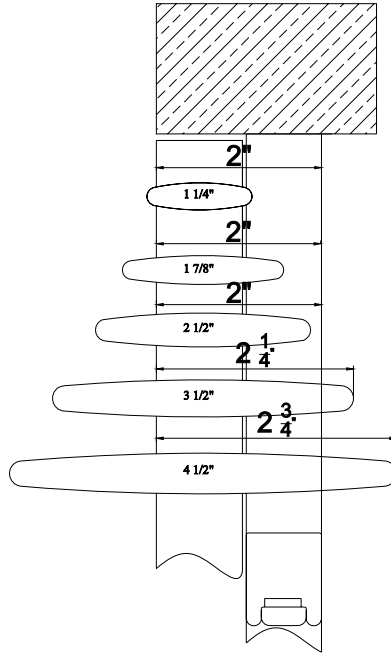

Hang Strip (Behind the panel)

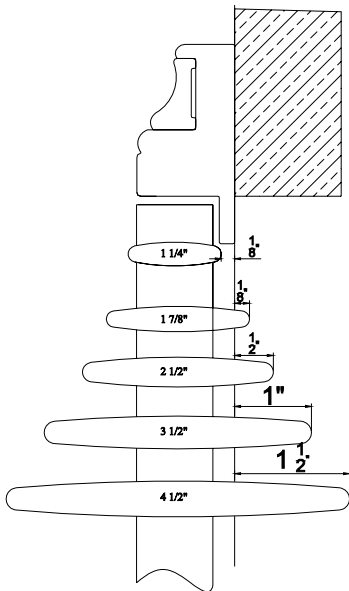

2" Classic Deco Frame

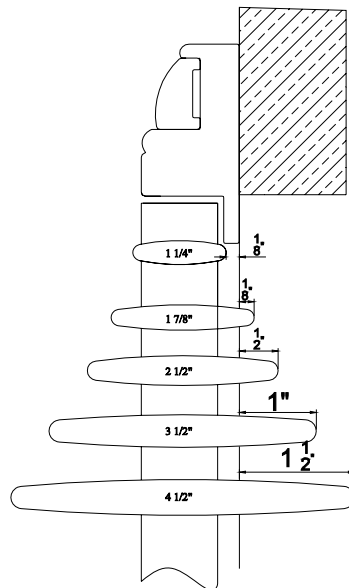

2" Camber Deco Frame

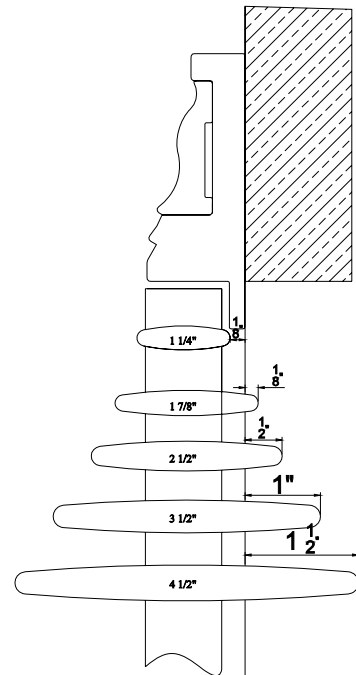

3" Ridge Deco Frame