

GRABER | DELIGHT IN EVERY DETAIL



Graber Z-Wave English/US Price Guide

MOTORIZATION FEATURING BLUETOOTH AND Z-WAVE TECHNOLOGIES

Motorization Features

Motorized Shades	2
Radio Frequency (RF)	2

Motorization Size Considerations

CrystalPleat® Cellular Shades Motorized Lift	3
Pleated Shades Motorized Lift	4
Fresco® Roman Shades Motorized Lift	5
Tradewinds® Natural Shades Motorized Lift	6
Artisan Roman Shades Motorized Lift	7
Mezzanine Layered Shades Motorized Lift and Light Gap	8
Overture Sheer Shades Motorized Lift and Light Gap	9
Lightweaves® Roller and Solar Shades Motorized Lift	10
Motorized Lift, and Dual Shade: Mounting Depth Illustrations	11

Motorization Options

Lightweaves Roller and Solar Shades: 12-Volt Motor Maximum Shade Size	16-21
Lightweaves Roller and Solar Shades: Dual Shades Maximum Shade Size	20-27
Power Considerations	22-23
Power Components	24
Z-Wave Motorization Controls	25
Standard Remote Mounting Options	26
Single-Channel Remote Mounting Options	26
Multi-Channel Remote Mounting Options	26

GRABER®

MAY 2023

Motorization Features

Motorized Shades

Refer to individual product information guide for specific option for the product being ordered. See price charts for pricing.

Radio Frequency (RF)

Graber motorized shades feature advanced Bluetooth and Z-Wave radio technology that provides reliable, effortless operation of window coverings. Graber motorized shades are quiet, simple to install and adjust, and simple to operate. These automated shades also feature:

Bluetooth Radio Frequency Features

Bluetooth technology allows you to control your shades directly from your phone without a hub or gateway. Any iOS or Android device is compatible.

- Control your shades directly from your phone or tablet without a gateway
- Operate your shades within Bluetooth range
- Create and schedule routines to automate your window coverings
- A safer alternative to accessible cords; ideal for homes with children and pets
- Provides easy operation for hard to reach or large windows



Z-Wave Radio Frequency Features

- Operates your shades virtually anywhere within 65 feet
- Supported by an alliance of countless smart home products and home automation providers making integration simple and inexpensive.
- Easily integrate with voice control devices
- A safer alternative to accessible cords; Ideal for homes with children and pets.
- Provides easy operation for hard to reach or large windows.

Motorization Size Considerations

CrystalPleat® Cellular Shades Motorized Lift

Order Entry: 12V Z-Wave and Bluetooth Motor

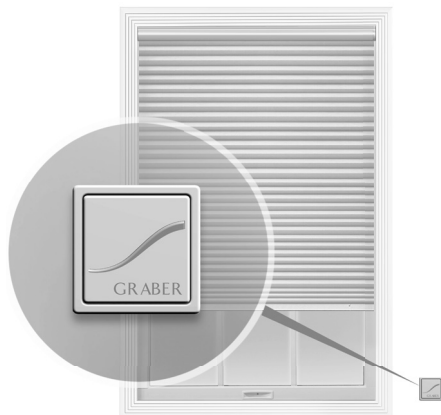

Refer to individual product information guide for specific option for the product being ordered.

See page 2 for benefits of using Bluetooth & Z-wave motorization.

Product Specifications

- Motor located on right side within headrail
- Available as corner and bay window application
- Available with Wood Cornice and Valance
- Available with reversible fabric at time of order
- Available with lightblocking strip
- Available with Fabric Wrapped headrail.
- Rail colors can be specified at time of order
- Available with room-darkening channels
- Not available with top down continuous-loop, sun up/sun down, combination shades, SkyTrack™ Skylight, specialty shapes or multiple shades on one headrail
- Not available with hold down brackets or side mount brackets

Control and Power Options

- Multiple control and power options available; see Z-Wave options for availability

NOTE: Motorization components and accessories have a five-year limited warranty, excluding batteries.

Size Considerations	Minimum Width [†] (inches)	Maximum Width (inches)	Minimum Height (inches)	Maximum Height (inches)
Cellular Shades	20	144*	9	144 *
Bottom up/Top Down	28 5/8	120	9	86

*This is the shade size maximum limit for this motor type, shades size limit may be smaller based on specific fabric type.

Cell Size	Collection Name	Maximum Shade Size (square inches)	Bottom up/Top Down Maximum Shade Size (square inches)
1/2" Double Cell	Sanctuary	10,000	6,000
1/2" Double Cell	Splendor	12,500	8,200
3/4" Single Cell	Champagne Toast, Couture LF and BO, Enchantment BO, Infuse LF and BO, Kinsley LF and BO, Montage BO, Prestige BO, Sanctuary, Scroll FR, Valletta BO	12,500	8,200
3/4" Single Cell	Enchantment LF, Montage LF, Prestige LF, Splendor LF	17,000	9,600
3/4" Single Cell	Discovery, Endeavor, Simply Sheer, Valletta LF	20,800	10,600
9/16" Single Cell	Discovery	12,500	N/A
9/16" Single Cell	Endeavor	17,000	N/A
1 1/4" Single Cell	Splendor	14,000	9,200
1 1/4" Single Cell	Champagne Toast, Sanctuary, Valletta LF and BO	12,500	8,200

NOTE: For all inside mount applications, 3/8" deduction is taken by manufacturer on overall width.

Depth Requirements

Cell Size	Headrail Dimensions (inches)	Minimum Depth Mount (inches)	Flush with Casing (inches)
3/4" single cell 1/2" double cell	1 9/16" x 2 3/8"	5/8"	2 3/8"
9/16" single cell	1 9/16" x 2 1/8"	5/8"	2 3/8"
1 1/4" single cell	1 7/8" x 3 1/16"	1"	3 1/8"

Size Considerations

Pleated Shades Motorized Lift

Order Entry: 12V Z-Wave and Bluetooth Motor



Refer to individual product information guide for specific option for the product being ordered.

See page 2 for benefits of using Bluetooth & Z-wave motorization.

Product Specifications

- Motor located on right side within headrail
- Available as corner and bay window application
- Available with Wood Cornice and Valance
- Available with Dayliner or Midnight liner
- Available with lightblocking strip
- Rail colors can be specified at time of order
- Not available with bottom up/top down, sun up/sun down, combination shades, SkyTrack™ Skylight, specialty shapes or multiple shades on one headrail
- Not available with hold down brackets, side mount brackets or room-darkening side channels

Control and Power Options

- Multiple control and power options available; see Z-Wave options for availability

NOTE: Motorization components and accessories have a five-year limited warranty, excluding batteries.

Size Considerations	Minimum Width [†] (inches)	Maximum Width (inches)	Minimum Height (inches)	Maximum Height (inches)
1" FashionPleat®	20	144* [†]	9	96
1" EvenPleat®	20	120* [†]	6	96
2" EvenPleat	20	144* [†]	12	144*

*This is the shade size maximum limit for this motor type, shades size limit may be smaller based on specific fabric type.

[†]Based on fabric width with overlaps.

[†]For all inside mount applications, 3/8" deduction is taken by manufacturer on overall width.

Pleat Size	Collection Name	Maximum Shade Size (square inches)
1" Pleated	Aberdeen, Canyon Ridge, Cloud Metal, Debonair, Desert, Grasscloth, Marina, Prescott, Sahara Ridge, Serendipity, Spring Bloom, Terrain	9,000
1" Pleated	Allure, Inkblot, Sheer Linen	11,500
1" Pleated	Blackout and Privacy Liner Only	13,000
2" Pleated	Aberdeen, Cloud Metal, Debonair, Desert, Sahara Ridge, Serendipity, Spring Bloom, Terrain	7,500
2" Pleated	Sheer Linen	11,500
2" Pleated	Blackout and Privacy Liner Only	13,000

Depth Requirements

Shade Type	Headrail Dimensions (inches)	Partially recessed headrail in window casing/molding Minimum Depth Mount (inches)	Fully recessed headrail in window casing/molding Flush with Casing (inches)
1" Pleat	1 7/16 x 2 1/8	5/8	2 3/8
2" Pleat	1 7/16 x 2 3/8	5/8	2 3/8

Size Considerations

Fresco® Roman Shades Motorized Lift

Order Entry: 12V Z-Wave and Bluetooth Motor

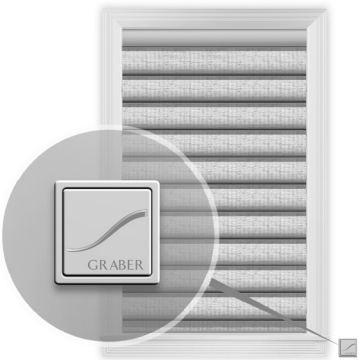

Refer to individual product information guide for specific option for the product being ordered.

See page 2 for benefits of using Bluetooth & Z-wave motorization.

Product Specifications

- Motor located on right side within headrail
- Available with both flat and looped styles
- Available as corner and bay window application
- Available with fabric valances and fabric valance trims
- Not available with bottom up/top down or multiple shades on one headrail
- Not available with hold down brackets or side mount brackets

Control and Power Options

- Multiple control and power options available; see Z-Wave options for availability

NOTE: Motorization components and accessories have a five-year limited warranty, excluding batteries.

Roman Size Considerations	Minimum Width* (inches)	Maximum Width (inches)	Minimum Height (inches)	Maximum Height (inches)
Roman Shades: Classic Flat or Looped	20	76†	18	96

*For all inside mount applications, 3/8" deduction is taken by manufacturer on overall width.

†Based on fabric width.

Lift Option and Shade Style	Headrail Dimensions (inches)	Headrail Mounting Options	
		Partially recessed headrail in window casing/molding Minimum Depth Mount (inches)	Fully recessed headrail in window casing/molding Flush with Casing (inches)
Motorized Lift: Flat	1½ x 2	5/8	2 ½
Motorized Lift: Looped	1½ x 2	5/8 (fabric loops will overhang approximately 3" into the room)	2½ (fabric loops will overhang approximately 3" into the room)

Size Considerations

Tradewinds® Natural Shades Motorized Lift

Order Entry: 12V Z-Wave and Bluetooth Motor

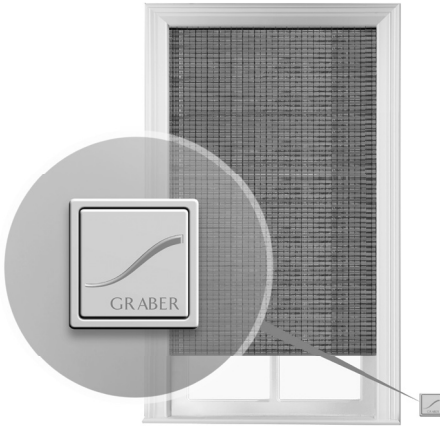

Refer to individual product information guide for specific option for the product being ordered.

See page 2 for benefits of using Bluetooth & Z-wave motorization.

Product Specifications

- Motor located on underside of hardwood headrail on right side
- Available with Standard Roman and Old Stle Roman styles
- Available with multiple shades on one headrail; each panel will have a motor and power source and there will be 1/2" gap between panels
- Available with 9" standard valance, 9" premiere valance, or 9" deco-trim valance
- Available with: fabric edge banding, hem options, privacy and room-darkening liners
- Available with deco-trim hems and accent gimp
- Available as corner and bay window application
- Available with Wood Cornice and Valance
- Not available with bottom up/top down, cut outs, turned headrail or specialty shapes
- Not available with hold down brackets or side mount brackets

Control and Power Options

- Multiple control and power options available; see Z-Wave options for availability

NOTE: Motorization components and accessories have a five-year limited warranty, excluding batteries.

Natural Shades Size Considerations

Style	Minimum Width (inches)	Maximum Size	
		Shade (square inches)	With Liner (square inches)
Inan, Moniz, Lipo, Revelry, Serenity, Toushan II	18	2,755	2,333
Denver, Brooklyn, Stateside, Reminisce	18	4,493	3,466
Bellamy, Seasons	18	5,194	3,878
Boardwalk, Merino, Sarto	18	6,058	4,330
Bayport, Beachfront, Hadley, Kelton, Oxford, Paralian, Verity, Wild Haven	18	6,854	4,723
Berwick, Cameron, Cherish, Interlude, Olympia, Purcell, Rowen, Saterra, Selene, Ventura, Tatum, Terrestrial, Zishan	18	9,149	5,712

Headrail Dimensions (inches)	Minimum Depth Mount (inches)	Flush with Casing (inches)
5/8 x 2 1/4	3/4	Standard valance 3 3/16

Partially recessed valance in window casing/molding

Fully recessed valance in window casing/molding

Size Considerations

Artisan Roman Shades Motorized Lift

Order Entry: 12V Z-Wave and Bluetooth Motor



Refer to individual product information guide for specific option for the product being ordered.

See page 2 for benefits of using Bluetooth & Z-wave motorization.

Product Specifications

- Motor located on underside of hardwood headrail on right side
- Fabric wrapped headrail for a beautifully finished look; returns are standard on outside mount shades
- Available as pleat styles: Looped, Classic Flat, Seamless, or Relaxed
- Available with Liner styles: Standard, Water Repellent, Thermal, Flannel-back
- Available finishing options: Inset banding, edge banding, decorative tape
- Not available with multiple shades on one headrail, bottom up/top down, turned headrail, balloon shade or blackout lining
- Not available with hold down brackets or side mount brackets

Control and Power Options

- Multiple control and power options available; see Z-Wave options for availability

NOTE: Motorization components and accessories have a five-year limited warranty, excluding batteries.

Artisan Roman Shades Size Considerations

Width		Length	
Minimum (inches)	Maximum (inches)	Minimum (inches)	Maximum (inches)
24	96	18	Classic Flat, Seamless and Relaxed – 120, Looped – 103

Motorized Maximum Shade Area in Square Inches

Fabric Name	Standard or Water Repellent (square inches)	Thermal (square inches)	Flannel-Back (square inches)
Candor, Cloud Metal, Enchanting, Liana, Meredith, Piazza, Stanton	4,209	3,719	3,450
Absolute, Alea, Arcadia, Artesso, Aspirational, Beach Chalet, Bianca, Bisque, Bloomscape, Brandywine, Brooke, Callahan, Countryside, Diversions, Esperance, Gratitude, Grayson, Harmonious, Heilene, Hypnotic, Iconic, Kazlo, Manning, Newleaf, Pageantry, Palatial, Rainfall, Raleigh, Sea Paisley, Seafont, Spargel, Undertones, Valor, Whimsical	3,569	33,254	3,000
Affinity, Ainslie, Avid, Bountiful, Burnham, Casita, Chalkdust, Conceptual, Confidence, Downpour, Dreamscape, Florabar, Focus, Frond Mist, Gjusta, Hama, Ibiza, Imagination, Kelsey, Kings Garden, Kingsbury, Maisonette, Meadowlark, Mikado, Mysterious, Mystical, Painterly, Pastoral, Posy, Primavera, Reflection, Refuge, Richland, Rutherford, Sustained, Symbiotic, Textile, Tyrell, Uplifting, Venetian, Wonder, Woodblock	2,921	2,859	2,550
Assurance, Athens, Birch, Bursche, Carver, Checkerloom, Circumference, Cloverleaf, Cooperative, EarthWise, EnviroLiving, Environment, Garden, Meditations, Monorail, Skipping Rocks, Soliloquy, Steward, Thistlerock, Wexler	2,489	2,423	2,130

If fabric not listed, it is not available with the motorized lift option.

NOTE: Area is ordered width x ordered height in square inches.

Headrail Dimensions (inches)	Minimum Depth Mount (inches)	Flush with Casing (inches)
2¼ D x ⅝ L	¾	2⅞



Partially recessed headrail in window casing/molding

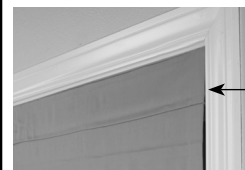

Fully recessed headrail in window casing/molding

Size Considerations

Mezzanine Layered Shades Motorized Lift

Order Entry: 12V Z-Wave and Bluetooth Motor



Refer to individual product information guide for specific option for the product being ordered. See page 2 for benefits of using Bluetooth & Z-wave motorization.

Product Specifications

- Motor located on right or left side; standard is on right
- Fabric wrapped cassette standard and creates a cohesive appearance in the window
- Static-guard is necessary during dry conditions to prevent static build up
- Available as corner and bay window application
- Not available with hold down brackets or side mount brackets
- Not available with Wood Cornice or Valance

Control and Power Options

- Multiple control and power options available; see Z-Wave options for availability

NOTE: Motorization components and accessories have a five-year limited warranty, excluding batteries.

Light Gap

The fabric width is narrower than the finished shade width of the tube and its components. See chart below for light gap.

Motor End		Idle End	
Inside Mount (inches)	Outside Mount (inches)	Inside Mount (inches)	Outside Mount (inches)
1 ¹ / ₁₆	1	3 ³ / ₄	1 ¹ / ₁₆

Layered Shades Size Considerations

Style Name	Maximum Width* (inches)	Maximum Height* (inches)	Style Name	Maximum Width* (inches)	Maximum Height* (inches)
Atlantic Waves	100	75	Herard	97	77
Bernina	96	110	Linen Dream	95	72
Coastal Collection	98	75	Oceanfront	99	60
Coastal Ridge	98	60	Palmetto	97	100
Cordillera	85	75	Papyrus	98	60
Cottonwood	101	100	Refreshed	93	84
Crestones	97	84	Riptide	100	110
Culebra	95	110	Seascape	98	77
Glorieta	98	110	Seaside Resort	99	110
Glorieta Sheen	98	110	Spascape	100	77
Heathered	95	77	Vanoise	91	95

Minimum width: 16".

Minimum length: 12".

*If the height is shorter than the maximum, a slightly larger width may be available to order. Maximum width is 102".

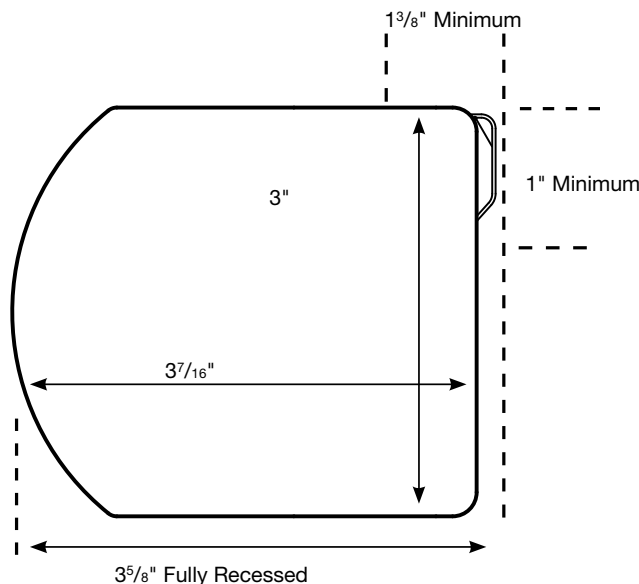

Fabric-Wrapped Cassette

Minimum Mounting Depth	1 ³ / ₈ "
Minimum Mounting Depth, Flush Mount	3 ⁵ / ₈ "

Size Considerations

Overture Sheer Shades Motorized Lift

Order Entry: 12V Z-Wave and Bluetooth Motor



Refer to individual product information guide for specific option for the product being ordered.

See page 2 for benefits of using Bluetooth & Z-wave motorization.

Features

- Motor located on right or left side; standard is on right
- Fabric wrapped cassette standard and creates a cohesive appearance in the window
- Available as corner and bay window application
- Not available with hold down brackets or side mount brackets
- Not available with Wood Cornice or Valance

Control and Power Options

- Multiple control and power options available; see Z-Wave options for availability

NOTE: Motorization components and accessories have a five-year limited warranty, excluding batteries.

Light Gap

The fabric width is narrower than the finished shade width of the tube and its components. See chart below for light gap.

Motor End		Idle End	
Inside Mount (inches)	Outside Mount (inches)	Inside Mount (inches)	Outside Mount (inches)
1	1 ⁵ / ₁₆	1 ¹ / ₁₆	5 ⁵ / ₈

Sheer Shades Size Considerations

Style Name	Maximum Width* (inches)	Maximum Height* (inches)	Style Name	Maximum Width* (inches)	Maximum Height* (inches)
Alpine 2"	79	110	Modern Grid 1" 5302, 5303, 5304	98	87
Coastal Waves 2"	96	105	Modern Grid 1" 5300	94	75
Deco Diamond 2"	96	105	Roslin 1"	94	75
Deco Diamond 3"	96	65	San Simeon 3"	96	65
Evening Star 2"	71	85	Starlight 2"	96	105
Glessner 2"/Glessner 3"	96	105	Starlight 3"	96	65
Glessner Sheen 2"/Glessner Sheen 3"	98	110	Sun Reflections 2"	96	105
Glessner Woven 2"/Glessner Woven 3"	96	110	Surfside 2"	96	105
Lustrous 1"	102	69	Surfside 3"	96	65
Lustrous 2"	96	105	Winchester 1"	97	87
Marisco 2"/Marisco 2 3/4"	94	99	Winchester Sheen 1"	102	69
Modern Grid 1" 5301	102	69	Winchester Woven 1"	97	87

Minimum width: 16".

Minimum length: 12".

*If the height is shorter than the maximum, a slightly larger width may be available to order. Maximum width is 102".

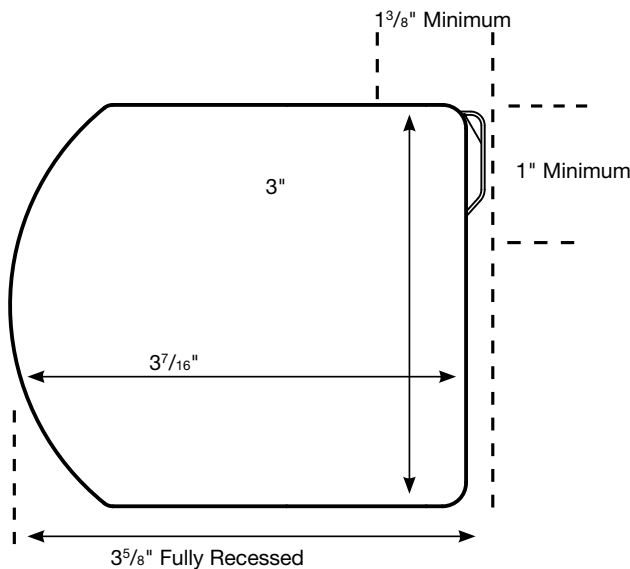

Minimum Mounting Depth	1 ³ / ₈ "
Minimum Mounting Depth, Flush Mount	3 ⁵ / ₈ "

Fabric-Wrapped Cassette

Size Considerations

Lightweaves® Roller and Solar Shades Motorized Lift

Order Entry: 12V Z-Wave and Bluetooth Motor



Inside Mount Light Gap
Refer to Light Gap Chart

Refer to individual product information guide for specific option for the product being ordered.
See page 2 for benefits of using Bluetooth & Z-wave motorization.

Product Specifications

- Motor located on right or left side; standard is on right
- Available with standard or reverse roll; reverse roll not available with any valance option
- Available with valance styles: cassette, contour, fascia, wood valance and wood cornice
- Available as corner and bay window application
- Available with fabric rotated 90° (width for height) and seaming
- Available with as Dual Shade (integrates two fabrics that can be independently raised and lowered as needed); each shade requires a power source)
- Available with finishing options: scallops, gimp trim, bead trim
- Available with side and sill channels and pocket
- Not available with hold down brackets

Control and Power Options

- Multiple control and power options available; see Z-Wave options for availability

NOTE: Motorization components and accessories have a five-year limited warranty, excluding batteries.

Light Gap		
Valance Type	Motor End (Inside Mount)	Idle End (Inside Mount)
Contour, Fascia, Flat, No Valance	9/16	7/8
Cassette - all sizes	9/16	1
Dual - No Cassette	9/16	7/8
Dual with Cassette	9/16	1

Size Considerations	
Minimum Width (inches)	Minimum Height (inches)
16	13

NOTE: See size charts on following pages.

Size Considerations

Motorized Lift, and Dual Shade: Mounting Depth Illustrations

The following diagrams illustrate the mounting depth requirements for shades mounted inside window casements.

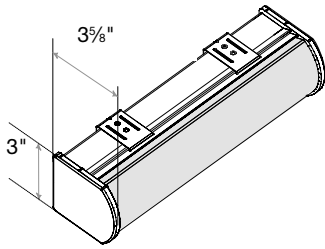

Small Cassette Valance
1 3/8" Minimum Inside Mount

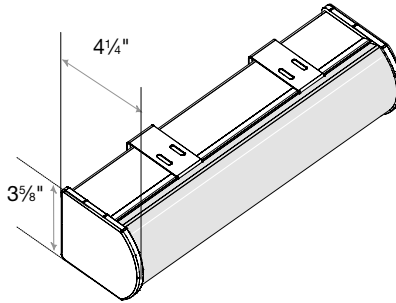

Medium Cassette Valance
1 3/4" Minimum Inside Mount

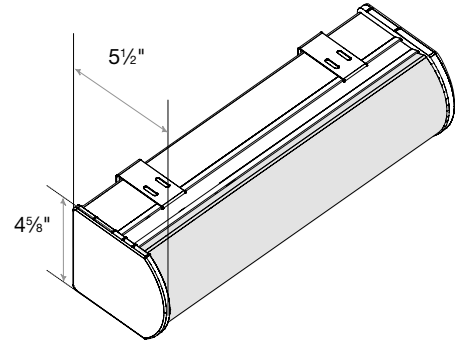

Large/Dual Cassette Valance
1 3/4" Minimum Inside Mount

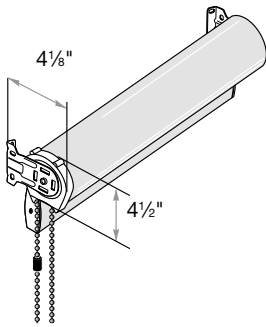

No Valance*
3/4" Minimum Inside/Side Mount

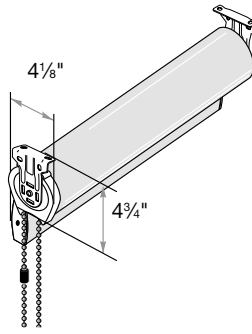

No Valance*
4 1/8" Minimum Inside/Top Mount

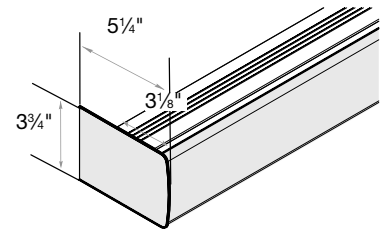

Contour Valance
2 7/16" Minimum Inside Mount
(return can be trimmed)

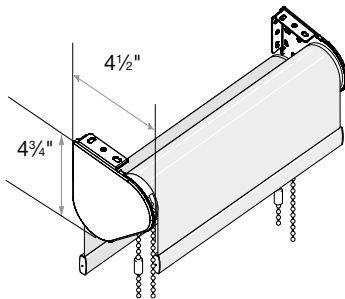

Dual Shade—No Cassette Valance
2" Minimum Inside/Top Mount
3/4" Minimum Inside/Side Mount

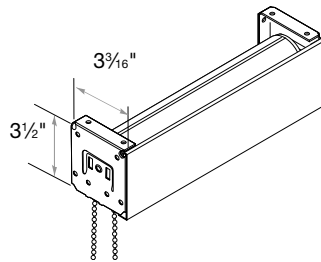

3" Fascia
2 3/4" Minimum Inside/Top Mount
3/4" Minimum Inside/Side Mount

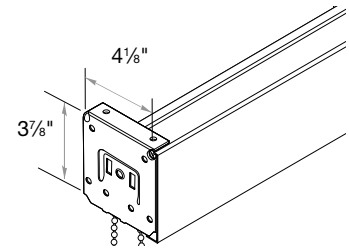

4" Fascia
3 3/4" Minimum Inside/Top Mount
1 1/2" Minimum Inside/Side Mount

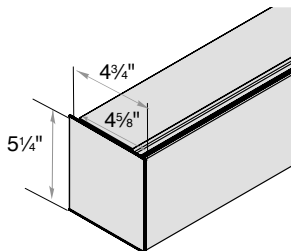

Flat Valance
2 15/16" Minimum Inside Mount
(return can be trimmed)

12V Non-Rechargeable
Non-rechargeable Motor
Minimum Width: 16"
Minimum Height: 13"

Features and Size Considerations

Lightweaves Roller and Solar Shades: 12-Volt Motor Maximum Shade Size

Valance Type	Normal Fabric Orientation						Fabric Turned Width for Height (railroaded)															
	Small Cassette		Medium Cassette		Large Cassette/ Contour Valance/ No Valance		3" Fascia		4" Fascia		Small Cassette		Medium Cassette		Large Cassette/ Contour Valance/ No Valance/ No Cassette/ No Valance at Maximum Width		3" Fascia		4" Fascia			
	Width (inches)	Height (inches)	Width (inches)	Height (inches)	Width (inches)	Height (inches)	Width (inches)	Height (inches)	Width (inches)	Height (inches)	Width (inches)	Height (inches)	Width (inches)	Height (inches)	Width (inches)	Height (inches)	Width (inches)	Height (inches)	Width (inches)	Height (inches)		
Fabric																						
Terrain(Gray Frost; Pale Adobe ; Pale Rhino)	78	112	89	135	89	135	89	135	89	135	NO RR	NO RR	NO RR	NO RR	NO RR	NO RR	NO RR	NO RR	NO RR	NO RR	NO RR	
Thesis(Weathered Stone; Bluebook White; Summer Khakis; Oxford Blue; Macho Macchiato; Dusky Titanium)	70	93	70	142	70	144	70	126	70	144	NO RR	NO RR	NO RR	NO RR	NO RR	NO RR	NO RR	NO RR	NO RR	NO RR	NO RR	
Tuvalu(Wisteria White; Silver Tree; Dusky Botanical)	94	121	94	121	94	121	94	121	94	121	NO RR	NO RR	NO RR	NO RR	NO RR	NO RR	NO RR	NO RR	NO RR	NO RR	NO RR	
Vanguard 1%(Authentic; Gentle Beige; Chrome; Pendulum)	83	89	79	116	79	116	79	116	79	116	83	89	80	111	80	111	80	111	80	111	80	111
Vanguard 1%(Elusive; Macedonia; Dew; Homage; Peloton)	82	94	79	112	79	112	79	112	79	112	82	94	79	112	79	112	79	112	79	112	79	112
Vanguard 3%(Authentic; Gentle Beige; Chrome; Pendulum)	83	96	80	120	80	120	80	120	80	120	83	96	81	113	81	113	81	113	81	113	81	113
Vanguard 3%(Elusive; Macedonia; Dew; Homage; Peloton)	82	96	79	116	79	116	79	116	79	116	82	96	79	114	79	114	79	114	79	114	79	114
Vanguard 5%(Authentic; Gentle Beige; Chrome; Pendulum)	84	96	81	121	81	121	81	121	81	121	84	96	82	114	82	114	82	114	82	114	82	114
Vanguard 5%(Elusive; Macedonia; Dew; Homage; Peloton)	82	101	80	120	80	120	80	120	80	120	82	101	81	113	81	113	81	113	81	113	81	113
Wayfarer(Sultry White; Maldives Gray)	92	144	92	144	92	144	92	144	92	144	NO RR	NO RR	NO RR	NO RR	NO RR	NO RR	NO RR	NO RR	NO RR	NO RR	NO RR	NO RR
Whitcomb(Paloverde; Invitation; Juniper)	90	118	89	132	89	132	89	132	89	132	NO RR	NO RR	NO RR	NO RR	NO RR	NO RR	NO RR	NO RR	NO RR	NO RR	NO RR	NO RR
Whitehall(Veranda; Wolverine; Nectar; Westminster; Seattle Mist)	87	106	82	144	82	144	82	144	82	144	87	106	87	108	87	108	87	108	87	108	87	108

NOTES: Due to continuous manufacturing improvements, minimums and maximums are subject to change. Please call customer service for up to date size considerations.
See dual shade section for motorization information.

Features and Size Considerations

This table provides the maximum shade size available by fabric, control type, and valance style. Only the large cassette valance is available for the dual shade. Fabric turned width for height (railroaded) may curl along its edge. This is not a defect in the product. Small and medium cassette valances are not available.

Lightweaves Roller and Solar Shades: Dual Shades Maximum Shade Size

Valance Type	Normal Fabric Orientation						Fabric Turned Width For Height (railroaded)					
	12V Motor No Cassette/ No Valance		12V Motor Large Cassette		12V Motor No Cassette/No Valance at Max Length		12V Motor No Cassette/ No Valance at Max Width		12V Motor Large Cassette at Max Length		12V Motor Large Cassette at Max Width	
	W (in)	H (in)	W (in)	H (in)	W (in)	H (in)	W (in)	H (in)	W (in)	H (in)	W (in)	H (in)
Aberdeen BO (Ingenue Pearl; Effervescence; Pristine; Dulcet Graphite)	67	108	68	97	NO RR	NO RR	NO RR	NO RR	NO RR	NO RR	NO RR	NO RR
Aberdeen LF (Ingenue Pearl; Effervescence; Pristine; Dulcet Graphite)	92	123	92	109	83	84	98	82	83	84	98	82
Arboretum BO (Serene; Monarch; Sirius; Distinguished)	72	108	73	101	75	84	89	82	75	84	89	82
Arboretum LF (Serene; Monarch; Sirius; Distinguished)	90	136	91	121	82	84	96	82	82	84	96	82
Bradley (Antique Silver; Hearthstone; Midas; Azurine; Majesty; Everest)	71	83	72	75	NO RR	NO RR	NO RR	NO RR	NO RR	NO RR	NO RR	NO RR
Bravado BO (Magnolia; Elusive Ecrú; Tumbled Stone; Canterbury Night)	74	90	75	82	NO RR	NO RR	NO RR	NO RR	NO RR	NO RR	NO RR	NO RR
Bravado LF (Magnolia; Elusive Ecrú; Tumbled Stone; Canterbury Night)	79	110	81	98	NO RR	NO RR	NO RR	NO RR	NO RR	NO RR	NO RR	NO RR
Broadcast (Constellation; Sonnet; Cashmere; Alfresco; Motif; Taliesin; Auster; Continental; Simplicity; Genuine; Gourmet; Serenade)	70	77	71	70	70	77	87	62	71	70	88	55
Cambridge LF (White; Off White; Inkwell; Clay; Hawaiian Blue; Academy; Mirage; Vernal Pond; Ivory)	94	121	94	121	95	110	95	110	95	110	95	110
Cambridge RD (Hawaiian Blue; Academy; Mirage; Vernal Pond; White; Off White; Inkwell ; Clay ; Ivory; Misty)	86	109	87	97	86	108	86	108	87	97	87	97
Cloud Frost (Fading Nimbus; Shell; Creamy Mocha)	80	120	80	119	NO RR	NO RR	NO RR	NO RR	NO RR	NO RR	NO RR	NO RR
Cloud Frost (Sea Stone)	82	99	83	88	NO RR	NO RR	NO RR	NO RR	NO RR	NO RR	NO RR	NO RR
Complex (Couture; Chance; Oceans; Visage)	71	84	72	76	NO RR	NO RR	NO RR	NO RR	NO RR	NO RR	NO RR	NO RR

NOTES: Due to continuous manufacturing improvements, minimums and maximums are subject to change. Please call customer service for up to date size considerations.

Seams may be added to fabrics to accommodate long shade requirements. Seams will be placed as close to the tube as possible; seam location is not selectable. Seams are visible when the shade is fully extended. Not available with RU28 rechargeable motor or RU30 Simple RTS motor.

Features and Size Considerations

This table provides the maximum shade size available by fabric, control type, and valance style. Only the large cassette valance is available for the dual shade. Fabric turned width for height (railroaded) may curl along its edge. This is not a defect in the product. Small and medium cassette valances are not available.

Lightweaves Roller and Solar Shades: Dual Shades Maximum Shade Size

Valance Type	Normal Fabric Orientation												Fabric Turned Width For Height (railroaded)			
	12V Motor No Cassette/No Valance				12V Motor Large Cassette				12V Motor No Cassette/No Valance at Max Length				12V Motor Large Cassette at Max Length			
	W (in)	H (in)	W (in)	H (in)	W (in)	H (in)	W (in)	H (in)	W (in)	H (in)	W (in)	H (in)	W (in)	H (in)	W (in)	H (in)
Fabric																
Conservancy-LF (Edelweiss; Feather Grass; Golden Morel; Flowering Ash; Silver Maple; Black Peony; Sea Salt)	74	88	63	97	NO RR	NO RR	NO RR	NO RR	NO RR	NO RR	NO RR	NO RR	NO RR	NO RR	NO RR	NO RR
Conservancy-BO (Edelweiss; Feather Grass; Golden Morel; Flowering Ash; Silver Maple; Black Peony; Sea Salt)	56	84	58	74	NO RR	NO RR	NO RR	NO RR	NO RR	NO RR	NO RR	NO RR	NO RR	NO RR	NO RR	NO RR
Consummate Silk (Opalescence; Posh Platinum; Bright Champagne; Pale Gold; Sandstone; Seafoam)	71	112	72	102	NO RR	NO RR	NO RR	NO RR	NO RR	NO RR	NO RR	NO RR	NO RR	NO RR	NO RR	NO RR
Debonair (Weekender Twill; Tan Gaberdine; Natural White; Harberdasher Gray)	76	125	77	113	NO RR	NO RR	NO RR	NO RR	NO RR	NO RR	NO RR	NO RR	NO RR	NO RR	NO RR	NO RR
Delphine BO (Mythical Gray; Evocative White; Island Paradise; Dark Earth)	72	98	74	88	NO RR	NO RR	NO RR	NO RR	NO RR	NO RR	NO RR	NO RR	NO RR	NO RR	NO RR	NO RR
Delphine LF (Mythical Gray; Evocative White; Island Paradise; Dark Earth)	95	110	79	126	NO RR	NO RR	NO RR	NO RR	NO RR	NO RR	NO RR	NO RR	NO RR	NO RR	NO RR	NO RR
EcoEncore (Mint Condition; Lunar Light; Cocoa Powder)	95	119	95	119	NO RR	NO RR	NO RR	NO RR	NO RR	NO RR	NO RR	NO RR	NO RR	NO RR	NO RR	NO RR
Empirical (White Shimmer; Complex Carbon; Modern Gray; Classic Khaki)	93	123	93	123	NO RR	NO RR	NO RR	NO RR	NO RR	NO RR	NO RR	NO RR	NO RR	NO RR	NO RR	NO RR
Emporium (Bookplate White)	89	115	75	119	NO RR	NO RR	NO RR	NO RR	NO RR	NO RR	NO RR	NO RR	NO RR	NO RR	NO RR	NO RR
Emporium (Silver Dollar; Vintage Letterpress; Sheet Music; Stepping Stone)	74	115	75	105	NO RR	NO RR	NO RR	NO RR	NO RR	NO RR	NO RR	NO RR	NO RR	NO RR	NO RR	NO RR
Emporium (Sepia Snapshot)	73	111	74	104	NO RR	NO RR	NO RR	NO RR	NO RR	NO RR	NO RR	NO RR	NO RR	NO RR	NO RR	NO RR
Essential (Classic White; Creamy Beige; Taupe; Smokey; Black; Black on Black; Forest Green; Canyon; Beige; Stone; Black)	70	144	70	144	77	62	91	60	77	62	91	60	77	62	91	60
Exposition (Consummate; Genesis; Wishlist; Resonance)	76	65	77	59	NO RR	NO RR	NO RR	NO RR	NO RR	NO RR	NO RR	NO RR	NO RR	NO RR	NO RR	NO RR

NOTES: Due to continuous manufacturing improvements, minimums and maximums are subject to change. Please call customer service for up to date size considerations.

Seams may be added to fabrics to accommodate long shade requirements. Seams will be placed as close to the tube as possible; seam location is not selectable. Seams are visible when the shade is fully extended. Not available with RU28 rechargeable motor or RU30 Simple RTS motor.

Features and Size Considerations

This table provides the maximum shade size available by fabric, control type, and valance style. Only the large cassette valance is available for the dual shade. Fabric turned width for height (railroaded) may curl along its edge. This is not a defect in the product. Small and medium cassette valances are not available.

Lightweaves Roller and Solar Shades: Dual Shades Maximum Shade Size

Valance Type	Normal Fabric Orientation						Fabric Turned Width For Height (railroaded)					
	12V Motor No Cassette/ No Valance		12V Motor Large Cassette		12V Motor No Cassette/No Valance at Max Length		12V Motor Large Cassette at Max Length		12V Motor No Cassette/ No Valance at Max Width		12V Motor Large Cassette at Max Width	
	W (in)	H (in)	W (in)	H (in)	W (in)	H (in)	W (in)	H (in)	W (in)	H (in)	W (in)	H (in)
Fabric												
Gleam (Gold Rush; Ebony Glimmer; Silver Shine; Glistening Waterfall)	78	102	80	90	NO RR	NO RR	NO RR	NO RR	NO RR	NO RR	NO RR	NO RR
Harmony (Pebble ; Tassel; Marina; Shiplap; Cityscape ; Harvest; Lavender)	92	124	93	112	NO RR	NO RR	NO RR	NO RR	NO RR	NO RR	NO RR	NO RR
LiveWell (Dew Kissed; Finely Frosted; Succulent; Sandbar; Icelandic; Seaspray)	70	89	71	82	70	87	86	73	71	82	88	65
Manifest BO (Freshwater Pearl; Flint Rock; Savvy Gray; Lifting Fog; Ciabattia; Cream Filled)	84	131	85	119	NO RR	NO RR	NO RR	NO RR	NO RR	NO RR	NO RR	NO RR
Manifest LF (Freshwater Pearl; Flint Rock; Savvy Gray; Lifting Fog; Ciabattia; Cream Filled)	92	144	92	144	NO RR	NO RR	NO RR	NO RR	NO RR	NO RR	NO RR	NO RR
Momentum (Soft Seashell; Parisian Cream; Luxe Leather; Etched Brown; Brushed Pewter; Toasted Spice)	71	92	72	83	NO RR	NO RR	NO RR	NO RR	NO RR	NO RR	NO RR	NO RR
Monticello (Mist; Burro; Dune; Tikki; Rust)	74	68	75	62	74	68	91	54	75	62	92	48
Nantucket (Vintage Veil; Taupe Utopia; Rich Sable; Spice)	77	62	78	56	NO RR	NO RR	NO RR	NO RR	NO RR	NO RR	NO RR	NO RR
Pannier (Black Dahlia; Creamy Mocha; Feather White; Riverbed Brown)	75	65	76	59	NO RR	NO RR	NO RR	NO RR	NO RR	NO RR	NO RR	NO RR
Paving Stone BO (Bechamel; Pale Adobe; Eventide; Almond Butter)	82	106	83	95	82	105	82	105	83	95	83	95
PlanetSafe (French Pastry; Gray Perfection; Cool Cave)	94	122	94	122	NO RR	NO RR	NO RR	NO RR	NO RR	NO RR	NO RR	NO RR
Plexus 1% (Renewal; Provisions; Chalcedony; Strately; Landmark; Travertine; Penumbra; Nutley Pier; Black Granite; Niche)	68	72	70	65	68	72	85	57	70	65	87	50

NOTES: Due to continuous manufacturing improvements, minimums and maximums are subject to change. Please call customer service for up to date size considerations.

Seams may be added to fabrics to accommodate long shade requirements. Seams will be placed as close to the tube as possible; seam location is not selectable. Seams are visible when the shade is fully extended. Not available with RU28 rechargeable motor or RU30 Simple RTS motor.

Features and Size Considerations

This table provides the maximum shade size available by fabric, control type, and valance style. Only the large cassette valance is available for the dual shade. Fabric turned width for height (railroaded) may curl along its edge. This is not a defect in the product. Small and medium cassette valances are not available.

Lightweaves Roller and Solar Shades: Dual Shades Maximum Shade Size

Valance Type	Normal Fabric Orientation										Fabric Turned Width For Height (railroaded)													
	12V Motor No Cassette/ No Valance		12V Motor Large Cassette		12V Motor No Cassette/No Valance at Max Length		12V Motor No Cassette/ No Valance at Max Width		12V Motor Large Cassette at Max Length		12V Motor Large Cassette at Max Width													
	W (in)	H (in)	W (in)	H (in)	W (in)	H (in)	W (in)	H (in)	W (in)	H (in)	W (in)	H (in)												
Fabric																								
Plexus 3% (Renewal; Provisions; Chalcedony; Stately; Landmark; Travertine; Penumbra; Nutley Pier; Black Granite; Niche)	69	73	70	66	69	73	85	58	70	66	87	51												
Plexus 5% (Renewal; Provisions; Chalcedony; Stately; Landmark; Travertine; Penumbra; Nutley Pier; Black Granite; Niche)	68	80	69	72	68	80	84	64	69	72	86	56												
Quintessence (White Enchantment; Flecked Gray; Gilded Linen; Gray Alloy; Black Facet)	66	93	67	84	NO RR	NO RR	NO RR	NO RR	NO RR	NO RR	NO RR	NO RR												
Regent (First Frost; Smoky Taupe; Fossil; Lulling Storm; Magnetic)	96	114	81	124	NO RR	NO RR	NO RR	NO RR	NO RR	NO RR	NO RR	NO RR												
Sahara Ridge (Vapor; Alabaster; Birch Grove)	81	82	82	74	NO RR	NO RR	NO RR	NO RR	NO RR	NO RR	NO RR	NO RR												
Sakura (White Lattice; Zen Gray; Craftsman)	67	56	69	50	NO RR	NO RR	NO RR	NO RR	NO RR	NO RR	NO RR	NO RR												
Sanguine (Blue Pueblo; White Serenity; Misty Morning; Gray Estate; Montauk Slate)	74	61	75	54	NO RR	NO RR	NO RR	NO RR	NO RR	NO RR	NO RR	NO RR												
Santorini (Desert Sands; Unexpected Umber; Evocative Ivory)	76	144	76	132	NO RR	NO RR	NO RR	NO RR	NO RR	NO RR	NO RR	NO RR												
Shadow (White; Beige; Tan; Light Gray; Dark Gray)	84	93	71	97	NO RR	NO RR	NO RR	NO RR	NO RR	NO RR	NO RR	NO RR												
Sheffield (Chelsea; Henley; Windsor; Tuscon; Eclipse; Weathered; Meadow; Manor)	78	122	80	109	NO RR	NO RR	NO RR	NO RR	NO RR	NO RR	NO RR	NO RR												
Solana BO(Drift ; Blue Breeze; Dandelion Wish; Brown Tint; Black Whirlwind; Sweet Dreams)	64	84	66	76	NO RR	NO RR	NO RR	NO RR	NO RR	NO RR	NO RR	NO RR												
Spring Bloom (Kissed Olive; Cultivated Kalamata; Tropical Garden; Sunmeadow; Botanical Garden; Cherry Blossom)	92	140	92	127	84	84	98	82	84	84	98	82												

NOTES: Due to continuous manufacturing improvements, minimums and maximums are subject to change. Please call customer service for up to date size considerations. Seams may be added to fabrics to accommodate long shade requirements. Seams will be placed as close to the tube as possible; seam location is not selectable. Seams are visible when the shade is fully extended. Not available with RU28 rechargeable motor or RU30 Simple RTS motor.

Features and Size Considerations

This table provides the maximum shade size available by fabric, control type, and valance style. Only the large cassette valance is available for the dual shade. Fabric turned width for height (railroaded) may curl along its edge. This is not a defect in the product. Small and medium cassette valances are not available.

Lightweaves Roller and Solar Shades: Dual Shades Maximum Shade Size

Valance Type	Normal Fabric Orientation						Fabric Turned Width For Height (railroaded)					
	12V Motor No Cassette/ No Valance		12V Motor Large Cassette		12V Motor No Cassette/No Valance at Max Length		12V Motor No Cassette/ No Valance at Max Width		12V Motor Large Cassette at Max Length		12V Motor Large Cassette at Max Width	
	W (in)	H (in)	W (in)	H (in)	W (in)	H (in)	W (in)	H (in)	W (in)	H (in)	W (in)	H (in)
Vanguard 3% (Authentic; Gentle Beige; Chrome; Pendulum)	84	92	70	101	84	92	84	92	70	101	86	82
Vanguard 3% (Elusive; Macedonia; Dew; Homage; Peloton)	83	92	71	87	83	92	83	92	71	87	85	82
Vanguard 5% (Authentic; Gentle Beige; Chrome; Pendulum)	85	92	71	101	85	92	85	92	71	101	87	82
Vanguard 5% (Elusive; Macedonia; Dew; Homage; Peloton)	83	97	85	86	83	97	83	97	85	86	85	86
Wayfarer (Sultry White; Maldives Gray)	92	144	92	144	NO RR	NO RR	NO RR	NO RR	NO RR	NO RR	NO RR	NO RR
Whitcomb (Paloverde; Invitation; Juniper)	91	114	76	126	NO RR	NO RR	NO RR	NO RR	NO RR	NO RR	NO RR	NO RR
Whitehall (Veranda; Wolverine; Nectar; Westminster; Seattle Mist)	88	102	73	114	88	102	88	102	73	109	89	90

NOTES: Due to continuous manufacturing improvements, minimums and maximums are subject to change. Please call customer service for up to date size considerations.

Seams may be added to fabrics to accommodate long shade requirements. Seams will be placed as close to the tube as possible; seam location is not selectable. Seams are visible when the shade is fully extended. Not available with RU28 rechargeable motor or RU30 Simple RTS motor.

Options

Power Considerations

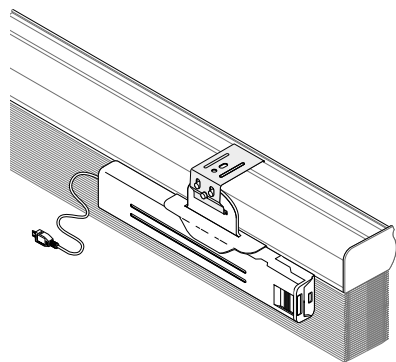

Cellular and Pleated
Battery Consideration

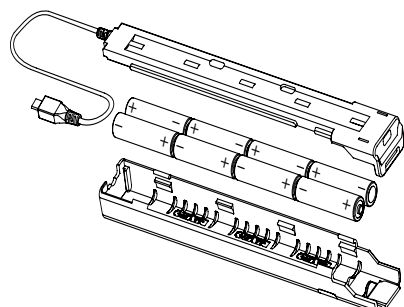

Battery Case (non-rechargeable solution)
Dimensions: 9 1/4" x 1 1/4" x 7/8"

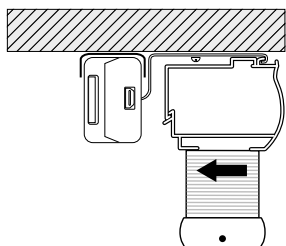

Ceiling/Inside Mount

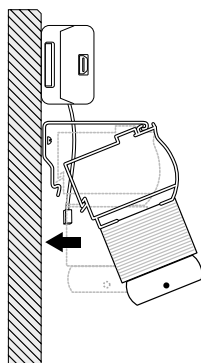

Outside Mount

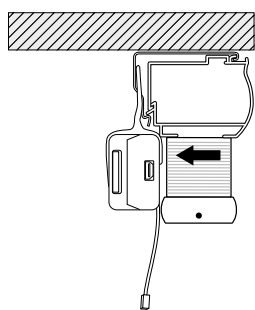

Inside Mount

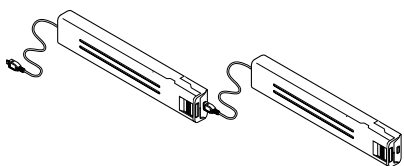

Dual Battery Cases

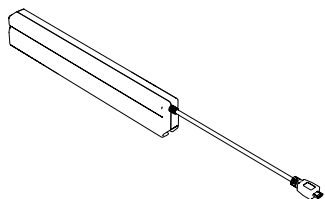

Rechargeable Battery Pack
Dimensions: 8 9/16" x 1 7/16" x 15/16"



Li-Ion Charger

Motors can be powered by non-rechargeable AA lithium batteries, rechargeable battery pack, plug-in transformer, or multi-motor power supply. Each shade requires a motor and appropriate power source.

Power Considerations

Larger shades consume more power while operating. When choosing the appropriate power source based upon the shade size we recommend the following power sources for the best performance.

Shade Size square inches	Non-Rechargeable Recommended Power Source	Rechargeable Battery Pack Estimated Battery Life Before Recharge* Single Pack Only
0 to 3,600	Batteries (single or dual), plug-in, or multi-motor power supply	~12 Months
3,600 to 7,200	Dual battery cases, plug-in, or multi-motor power supply	~6-12 Months
>7,200	Plug-in or multi-motor power supply only	~6 Months or Less

Battery Case Considerations

Battery power recommended for maximum of 10 shades for best battery performance.

Battery cases are installed in space outside of the product and can be a challenge to hide in some windows.

For Inside Mounts

- The cleanest and simplest method available for cellular and pleated shades is the integrated battery case hanger; this hanger attaches directly to a shade bracket to support the battery case while allowing the case to be removed for battery changes; additional recessed space will be needed

For Outside Mounts

- For outside mounts, battery cases can be installed above or to the side of the shade

NOTE: For best performance with non-rechargeable solutions, use only AA lithium batteries.

Dual battery cases installed end-to-end: require 21" of space (including connectors)

Battery case minimum recessed space (installed with bracket): product minimum recessed space + 3/4"

Options

Power Considerations

Solar/Roller, Natural Shades, Artisan Roman, Layered, and Sheer Shade Battery Considerations

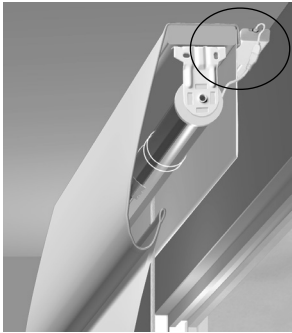

Artisan Roman/Natural Shades
Battery Pack
Mounted Behind

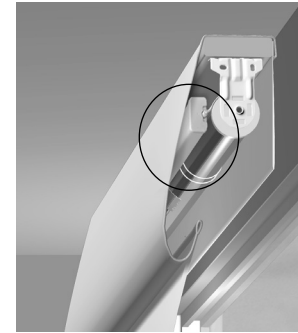
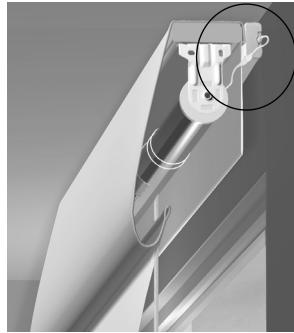

Artisan Roman/Natural Shades
Battery Pack
Mounted on Headrail

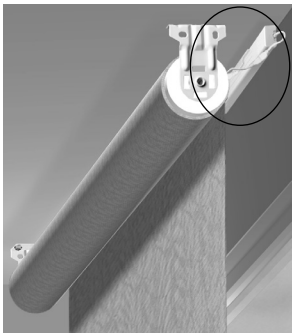

Solar Shades
Outside Mount
Battery Pack

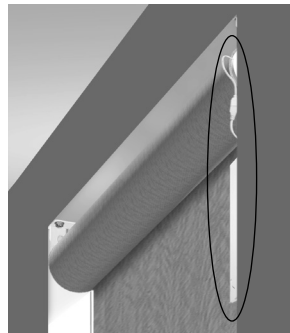

Solar Shades
Inside Mount Battery Pack

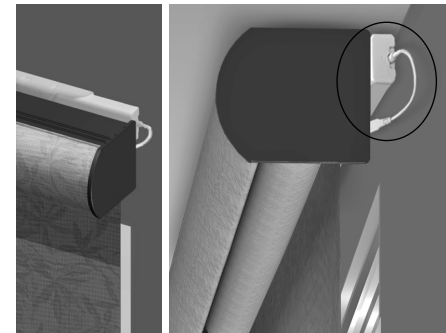

Solar, Layered, and
Sheer Shades with Cassette
Battery Pack

Motorization Power Options

Power Components

NOTE: These power supplies are not compatible with Radio Technology Somfy motors.

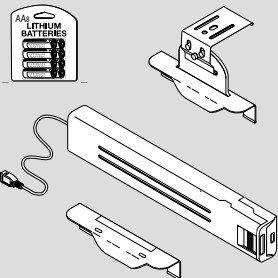

Reloadable Battery Case

- Reloadable: available with or without batteries
- Multiple mounting options provided
- Simple case design allows for easy battery replacement
- Recommend shades greater than 3,600 square inches utilize two single battery cases (dual cases) to extend battery life
- For best performance, use only AA lithium batteries (each case requires 8 AA lithium batteries)
- 48" and 96" extensions available, maximum of 2 per motor
- Battery power recommended for maximum of 10 shades for best battery performance

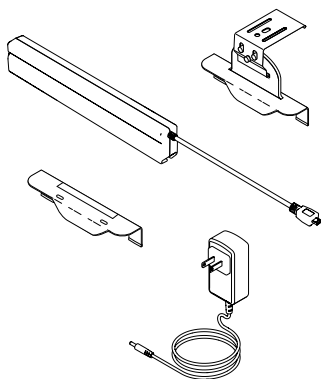

Rechargeable Battery Pack

- The rechargeable battery pack comes as a sealed pack with the batteries already included. Batteries are charged by plugging the charger into the pack.
- Multiple mounting options provided.
- 48" and 96" motor-to-battery extensions available, maximum of 2 per motor
- Rechargeable battery packs ship at 30% charge and must be fully charged prior to installation
- Dual pack configuration is not available or necessary for the rechargeable battery packs
- One Lithium-Ion Charger is required per order; sold separately
- Lithium-Ion charger cable is 6 feet
- Lithium-Ion charger has an LED that turns red to indicate charging and green to indicate fully charged
- Fully charging the rechargeable battery pack takes an average of 5 hours

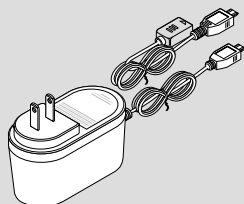

Plug-In Transformer

- Eliminates the need for batteries
- Small plug profile
- Cord can be concealed behind curtains or along trim
- 72" power cord and 96" extension cable (power cord and extension cable cannot be cut to length)
- 48" and 96" extensions available, maximum of 2 per motor
- We recommend shades greater than 7,200 square inches utilize a transformer to eliminate changing batteries frequently
- Available in white only

Transformer Dimensions

- 3¼" wide x 2" deep (not including plug) x 1½" tall (as you look at the plug in the outlet)
- Wire management components are not included with your motorized shade system
 - Refer to 12 volt power considerations for further details



Multi-Motor Power Supply

- Used when direct wiring the motorized window coverings
- Each motor is "home run" wired back to the multi-motor power supply using 16 gauge 2 conductor wire (must be purchased locally; Graber® does not supply)
- Power supply includes connectors
- Must be mounted indoors, NEMA rated
- Dimensions: 12" wide x 6" deep x 12" high
- Input: 100-120v AC / 200-240V AC at 3.3 amps
- Output: 10 amps; each shade port - 2 amp fused

NOTE: Due to the many variations of installations, wire management components are not included with your motorized shade system. There are numerous wire management products available at your local hardware store or home improvement center to help disguise the power cord when using a plug-in transformer. An example of a popular wire management accessory is wire channel. Wire channel is a vinyl sheathing that can be placed along the window casing or wall that will house and conceal exposed wiring for a clean and professional appearance.

Z-Wave Control Options

Z-Wave Motorization Controls

NOTE: These controls are not compatible with Radio Technology Somfy motors.



Standard Remote

The standard remote is meant to control an individual shade (one to one). This helps assure simple, reliable control as well as simplifying the process of readjusting pre-set positions should it become necessary—without removing power from adjacent shades. However, the standard remote can be paired to multiple shades to provide group control (onsite programming step).

- Not available for sheer or layered shades
- Includes convenient mounting hardware
- Battery included—CR2430
- Available in white
- Not available with Bottom Up/Top Down



Plus Remote

- Used to control single shades or a group of shades simultaneously
- Set and use an intermediate position for your shades
- Includes convenient mounting hardware
- Battery included—CR2430
- Available in white
- Not available with Bottom Up/Top Down



Plus Remote Decorator Wall Plate Kit (single-channel remote sold separately)

- Provides attractive mounting option to match look of existing light switches
- Locates the remote where most convenient for the user
- Helps prevent misplacing of remote when not in use
- Mounts flush to wall with included anchors, no cutting of drywall needed
- Available in white



Premium Remote (12-channel)

- 12-channel remote, controls up to 24 shades
- Control single shades on each channel or group shade performing the same function
- Control Bottom Up/Top Down cellular shades
- Shades are added to the remote from the manufacture. Channel assignment will need to be done at time of install.
- Convenient display provides easy programming
- Set and use an intermediate position for your shades
- Includes mounting wall plate and hardware; mounts to wall with anchors (see multi-channel remote mounting options)
- Batteries included—2 AAA
- Available in white

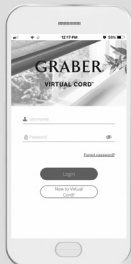

Graber Motorization Gateway

The Graber Motorization Gateway takes your motorized shades to the next level. The gateway allows you to control your shades away from your home, integrate with third party services, and schedule routines based on sunrise and sunset.

- Controls up to 10 devices (shade motors and remotes)
- Average Home Coverage: approx. 2,500 square feet depending on a variety of factors including number of walls and material of walls
- Multiple gateways can be added to an account on the Graber Motorization App to extend coverage and number of devices
- Control single shades individually with the ability to group shades in rooms for additional functionality
- Integrate directly with Amazon Alexa and Google Assistant for voice control
- Create routines to control multiple shades with the ability to schedule based on sunrise and sunset
- Set and use favorite positions
- Compatible with Apple and Android devices
- Gateway (shown in the image to the left) plugs directly into your wall outlet.
- Requires a 2.4Ghz, password protected, Wi-Fi network
- Multiple users can be added to an account with the option to assign different permission levels

Motorization Features

Standard Remote Mounting Options

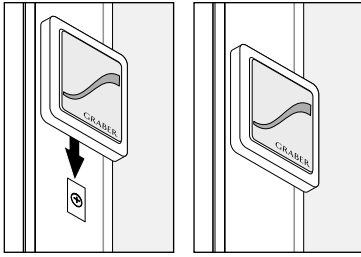

Z-Wave Standard Remote

Single-Channel Remote Mounting Options

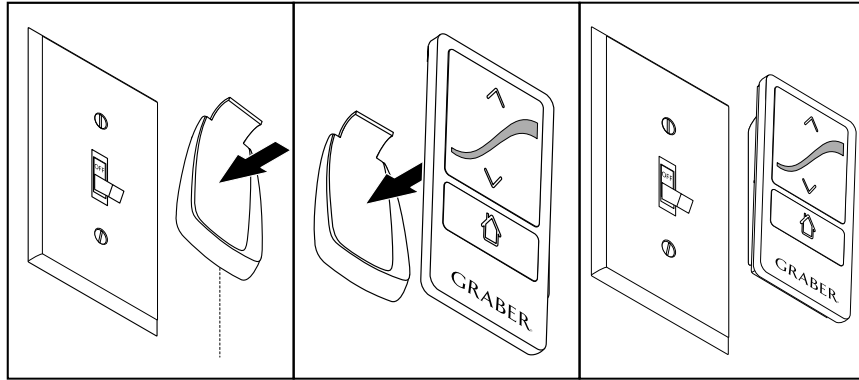

Z-Wave Plus Remote

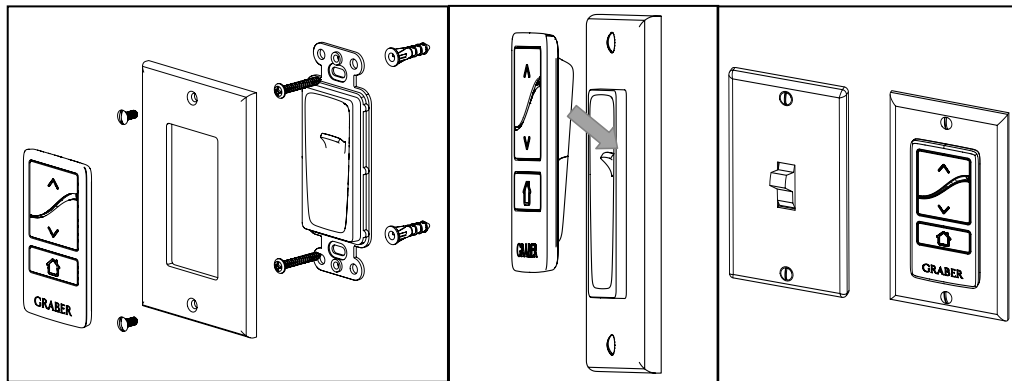

Optional Decorator Wall Plate Mount
(see options for details)

Multi-Channel Remote Mounting Options

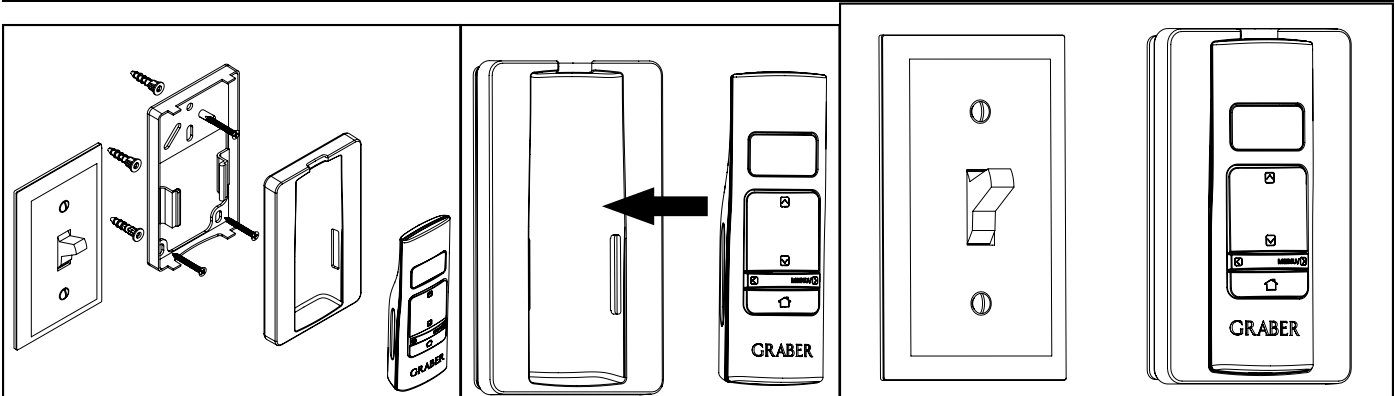

Z-Wave Premium Remote

GRABER®

Graber is a brand of Springs Window Fashions, the Best Experience Company

Graber and the Graber logo are registered trademarks of Springs Window Fashions, LLC.

(4/23) 23-426800

GRABER.

Graber Motorization

Designer US Price List — Effective January 2024

Motorization

See product information guide for illustrations of power and control items listed below. Select motor package and add to price of shade.

Motor Pricing

See options section for descriptions and illustrations of items listed below.

For motorized lift dual shades, one (1) motor, and one (1) power source are required for each motorized shade (total of two motors and two power sources if both shades of the dual shade are motorized lift).

A. Motor Pricing

Add price of motor to blind or shade price.

Order Entry: 12V BLE and ZW Motor without Remote (option 14)

Motor Options

Cellular, Pleated, and Classic Roman Shades	451
Roller, Solar, Layered, Artisan Roman and Sheer Shades	451
Natural Shades*	451
Cellular Button Up, Top Down	646

*Motor on a natural shade is priced per panel and can be ordered with multiple shades on one headrail.

NOTE: For all other non-motorization options, see individual price list for specific blind or shade.

B. Motorization Power Sources

Choose one (1) battery option or one (1) transformer per motor.

12-Volt Power Options

Battery Cases	
Single Non-Rechargeable, Reloadable Battery Case (empty)	48
Single Non-Rechargeable, Reloadable Battery Case (filled) (Includes 8 AA lithium batteries)	115
Dual cases recommended for shades over 3,600 square inches (2.3 square meters) to extend battery life.	
Dual Non-Rechargeable, Reloadable Battery Case (empty)	95
Dual Non-Rechargeable, Reloadable Battery Case (filled) (Includes 16 AA lithium batteries)	230
Other Power Options	
48" (121.9 cm) Extension Cable	21
96" (243.8 cm) Extension Cable	26
12 Volt DC Plug-In Transformer (includes 96" (243.8 cm) extension)	115
Multi-Motor Power Supply Kit (Up to 10 motors per power supply)	1179
12-Volt Rechargeable Power Options	
12-Volt Rechargeable Battery Pack	187
12-Volt 6 foot (1.9 m) Li-ion Charger	21

NOTE: For woven wood shades, surcharge is per panel.

C. Z-Wave Motorization Controls

Choose one or more remotes per order. Controllers are wire-free, battery and mounting hardware is included. App & Gateway are wire-free and do not require batteries.

Radio Frequency Remote Controls

Standard Remote	152
Plus Remote Single Channel	175
Plus Remote Decorator Wall Plate	18
Premium Remote Multi-Channel (includes wall mount and hardware)	310
Graber Motorization App and Gateway	315